

Entry Trim

For all Adams Rite Exit Devices

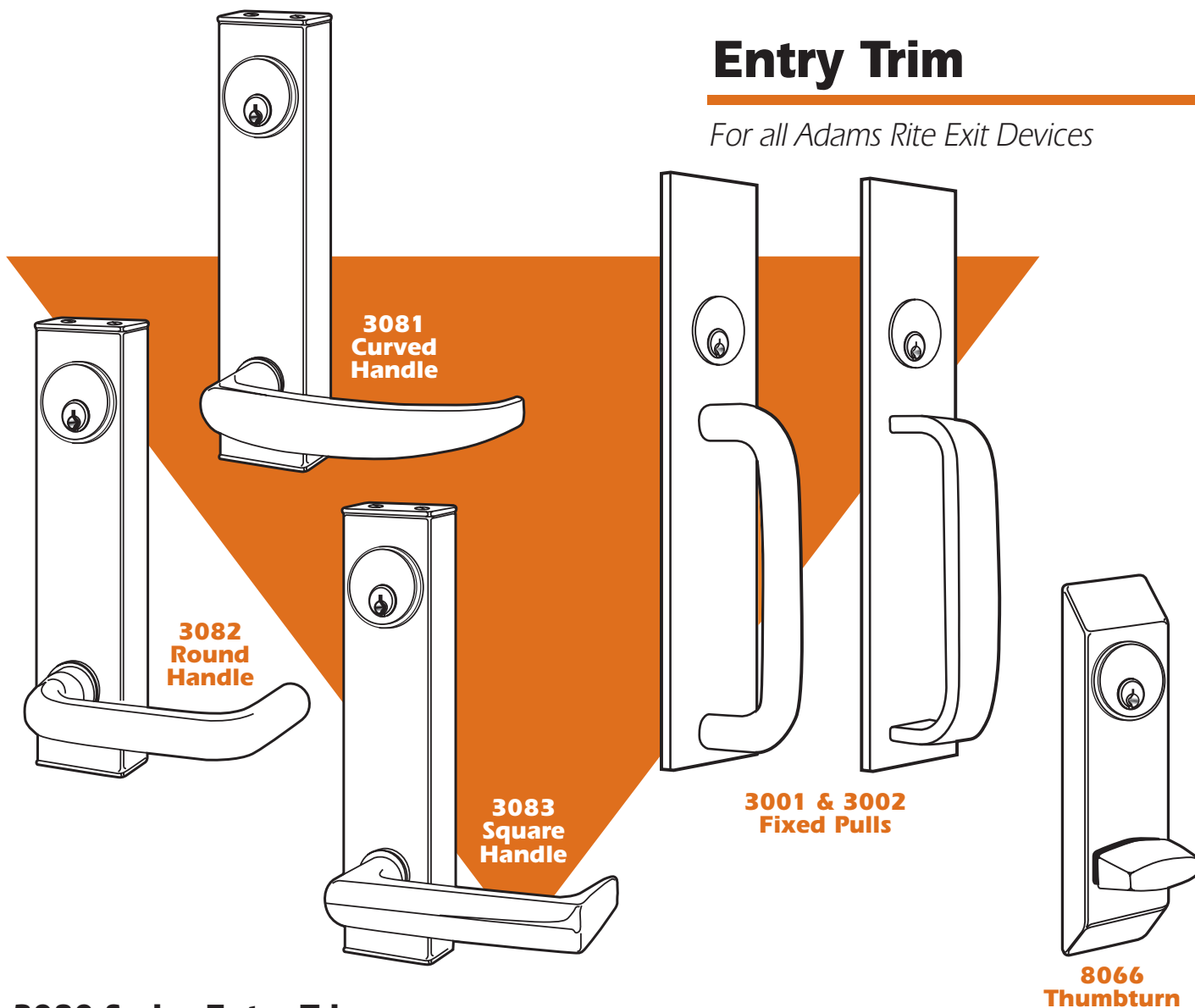

3080 Series Entry Trim

The 3080 Series provides outside activation of narrow stile aluminum, wood or hollow metal doors that have any type of Adams Rite Exit Device. Breakaway clutching mechanism protects the locked handle from vandalism or forced entry, in either direction. This also makes the trim rehandable in the field. All models share the same core components, so handles can be changed without having to replace the entire trim. Solid construction meets Grade 1 standards. An electrified version is also available for integrating with card readers, keypads and other access control devices. (See page AC-21.)

3001 & 3002 Fixed Pulls

US32D Satin Stainless Steel pulls have 2-3/4" x 1-1/2" escutcheon. Order with or without cylinder hole. For hollow metal and wood doors only.

8066 Thumbturn

Thumbturn and any standard mortise cylinder with MS cam allow entry control in two modes: latched, but openable by thumbturn, or latched with entry by key only with 8067 Nightlatch Kit.



ADAMS RITE
MANUFACTURING CO.

260 Santa Fe Street
Pomona, California 91767
(800) 872-3267 Fax: (800) 232-7329
www.adamsrite.com



Entry Trim

DIMENSIONS

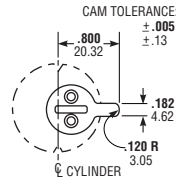
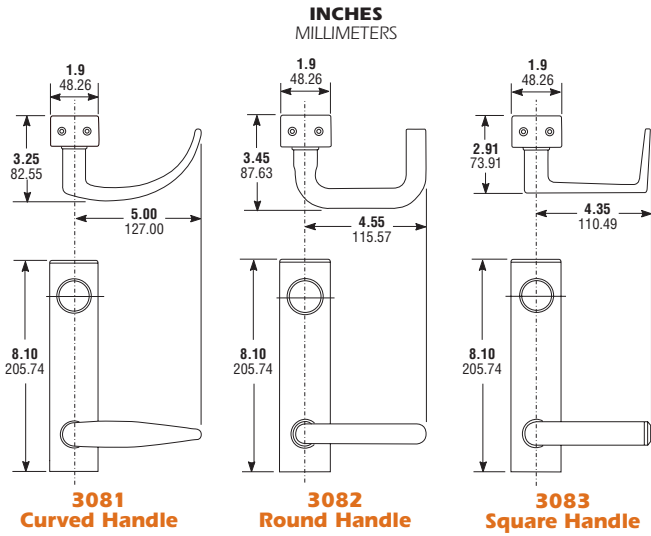

3080 Series Entry Trim accept any standard 1-5/32" diameter mortise cylinder with special MS[®] cam dimensioned as shown. Cylinders with MS[®] cams can be readily obtained from most cylinder manufacturers. See page SW-28 for cylinder make and trim ring information.

HOW TO ORDER

Specify quantity and the following information.
 Order Electrified version separately. See page AC-21.
 Order related hardware separately.

Model/Handle 3081 Curved 3082 Round 3083 Square	Cylinder Hole 3 with hole 9 w/o hole	Exit Device 1 SVR 6 CVR 3 Mortise 7 Rim 4 39/8900
---	---	--

3081 - 33 - US3

Finish	
US3 Bright Brass	10B Dark Bronze
US4 Satin Brass	US26 Bright Chrome
US9 Bright Bronze	US26D Satin Chrome
US10 Satin Bronze	SP Special

Specify quantity and the following information.
 Order related hardware separately.

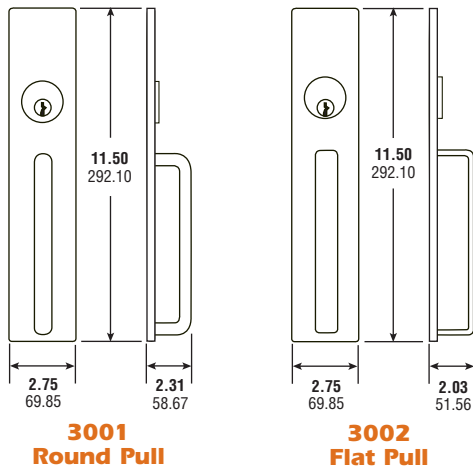

Model/Handle 3001 Round 3002 Flat	Cylinder Hole 1 w/o hole 2 with hole	Exit Device 1 Mortise, Rim 2 CVR 3 SVR
--	---	--

3001 - 11 - US32D

Finish US32D Satin Stainless Only

Specify quantity and the following information.
 Order related hardware separately.

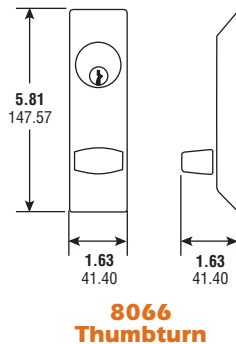

Exit Device 00 Mortise or CVR 01 Rim or SVR	Door Hand 07 Non-rated CVR, SVR or LHR Mortise 08 Non-rated Rim or RHR Mortise
--	---

8066 - 01 - 08 - US3

Finish		
628 Clear Anodized	US3 Bright Brass	10B Dark Bronze
313 Dark Bronze Anod.	US4 Satin Brass	US26 Bright Chrome
335 Black Anodized	US9 Bright Bronze	US26D Satin Chrome
	US10 Satin Bronze	SP Special