

**SCHLAGE®**

**AL-Series Service Manual**

---

## INTRODUCTION

This manual contains a complete listing of parts and assemblies of AL-Series locks manufactured by Schlage Lock Company, beginning in 1995. Exploded views of each lock function are provided with an accompanying dot chart to identify parts for replacement purposes.

In addition, this manual provides lock trim ordering procedures, cylinders, latches, strikes and all auxiliary components of AL-Series locks. Orders for finished components should always show finish designation. Orders for all Schlage® products must be placed through an authorized Schlage distributor or representative.

Schlage AL-Series lock parts are manufactured to close tolerances and are interchangeable between functions using the same parts. Conversion of functions is accomplished by identifying the parts necessary for substitution and following the assembly procedures as illustrated on the lock drawings.

For items not listed in this service manual, contact Schlage Lock Company for availability or allowable substitutions.

Schlage Lock Company reserves the right to make changes in designs and specifications or to make additions or improvements on its products without notice and without incurring any obligation to incorporate them on products previously manufactured. The Schlage Lock Company is not responsible for any modification, addition, or alteration to our product by others.

Schlage Lock Company  
 2401 Bayshore Boulevard  
 San Francisco, CA. 94134  
 (800) 847-1864  
 Fax: (800) 452-0663  
<http://www.schlagelock.com>  
 Printed in U.S.A.

## CERTIFICATIONS

ANSI/BHMA A156.2-1996.  
 Series 4000, Grade 2.  
 All functions U.L. listed for 3 hour doors.

## DOOR RANGE

1 3/8" to 1 7/8" Standard.  
 1 7/8" to 2" Regular parts, assembled to order.

## METRIC CONVERSION CHART

All dimensions shown in this service manual are in inches. To convert to millimeters, use the metric conversion chart shown below.

Inch	MM
1/32	0.79
1/16	1.59
3/32	2.38
1/8	3.18
5/32	3.97
3/16	4.76
7/32	5.56
1/4	6.35
9/32	7.14
5/16	7.94
11/32	8.73
3/8	9.53
13/32	10.32
7/16	11.11
15/32	11.91
1/2	12.70
17/32	13.49
9/16	14.29
19/32	15.08

Inch	MM
5/8	15.88
21/32	16.67
11/16	17.46
23/32	18.26
3/4	19.05
25/32	19.84
13/16	20.64
27/32	21.43
7/8	22.23
29/32	23.02
15/16	23.81
31/32	24.61
1	25.40
2	50.8
3	76.2
4	101.6
5	127.0
6	152.4
7	177.8

**TABLE OF CONTENTS**

<i>Assemblies</i>	<i>Description</i>	<i>Page</i>
AL10S	Passage Latch -----	2
AL25D	Exit Lock -----	3
AL40S	Bath/Bedroom Privacy Lock -----	4
AL50PD	Entrance/Office Lock -----	5
AL53PD	Entrance Lock -----	6
AL70PD	Classroom Lock -----	7
AL80PD	Storeroom Lock -----	8
AL85PD	Hotel/Motel Lock -----	9
AL170	Dummy Trim -----	10
Parts Index-----		11,12
Designs-----		12
Finishes, Lubrication, Tactile Warning-----		13
Cylinder Units and Parts-----		14,15
Interchangeable Cores, Design and Parts-----		16,17
Latch Units-----		18
Strikes-----		19
Installation Tools, Backset Links, Door Reinforcements-----		20
Keys, Key Array Chart, Key Gage, Cylinder Loading Tool-----		21
Plunger Assembly Instructions-----		22,23
Installation Instructions-----		24-26
Interchangeable Core Retrofit Kit Instructions-----		26
Ordering Procedures-----		27
Limited Warranty-----		28

## AL10S

### CHASSIS ASSEMBLY

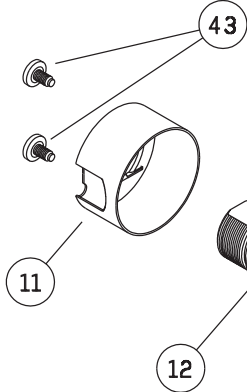

### TRIM ASSEMBLY

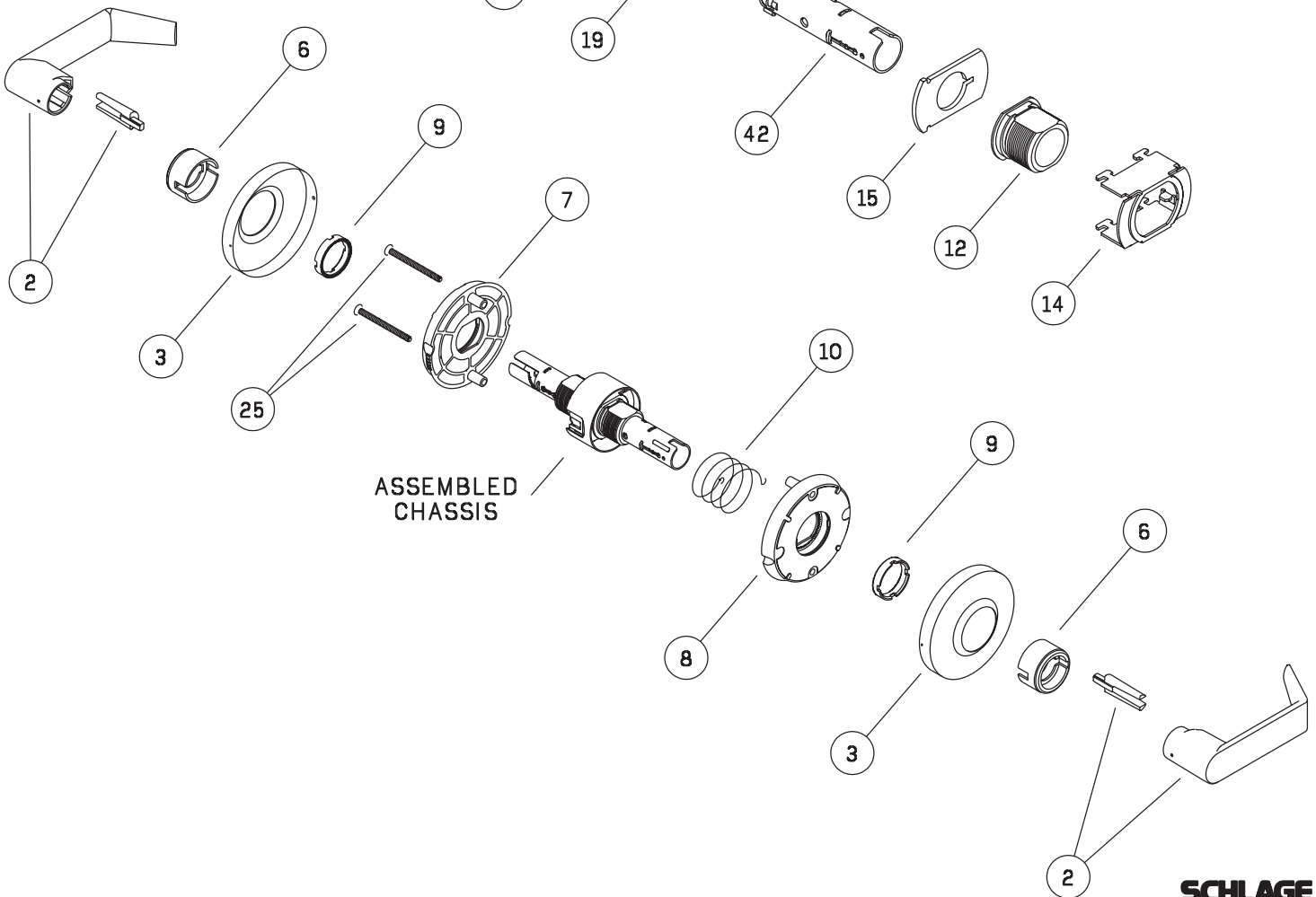

ASSEMBLED CHASSIS

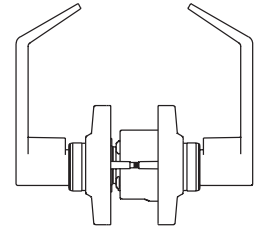

PASSAGE LOCK  
BOTH LEVERS ALWAYS UNLOCKED

# AL25D

## CHASSIS ASSEMBLY

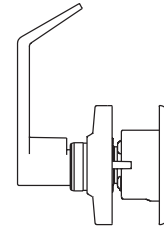

### EXIT LOCK

BLANK PLATE OUTSIDE. INSIDE LEVER ALWAYS UNLOCKED. (SPECIFY DOOR THICKNESS, 1 3/8", 1 3/4" or 2").

## TRIM ASSEMBLY

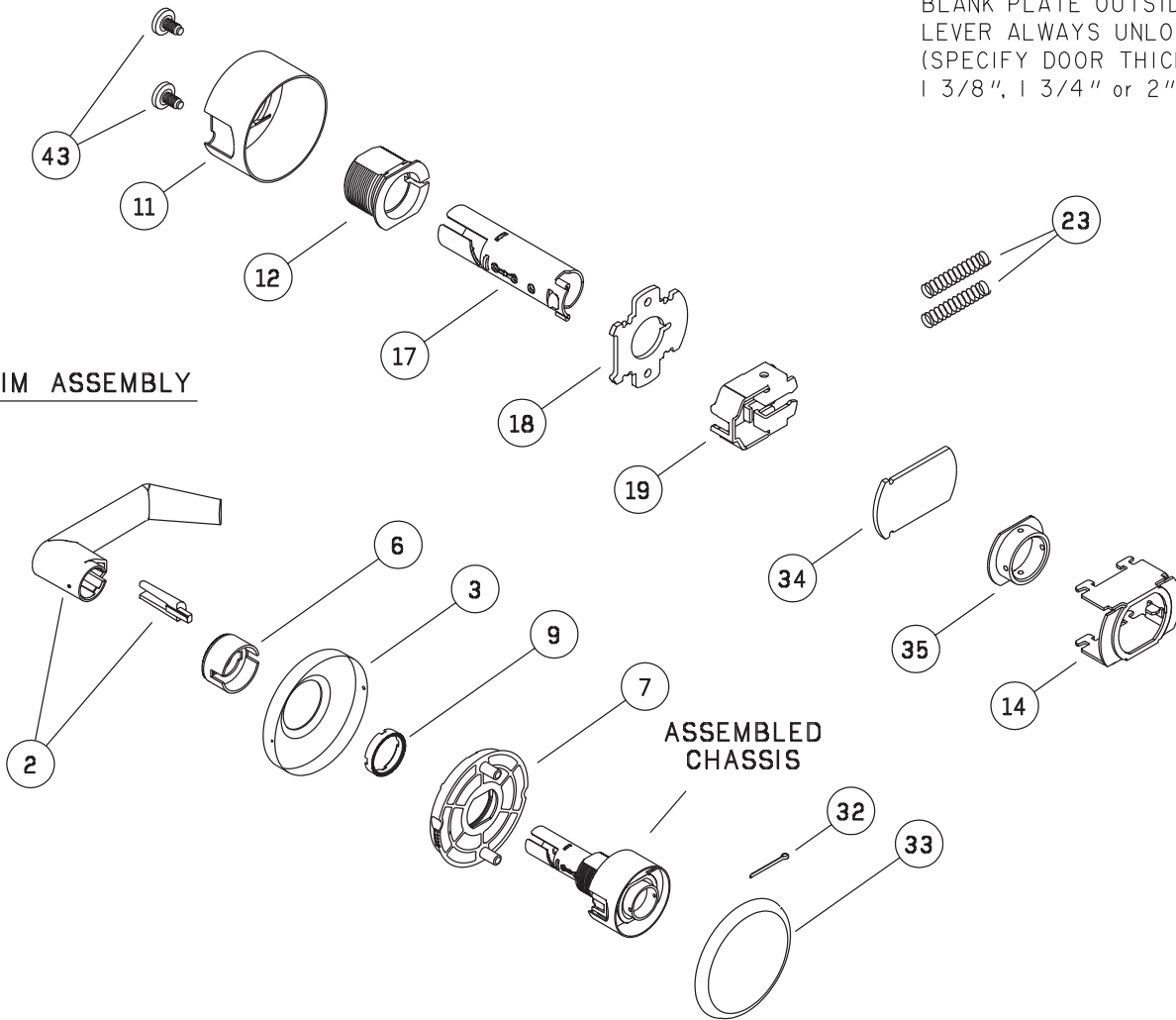

To adjust for door thickness, assemble blank rose (33) to hub (35) by aligning appropriate hole "A" or "B" to hole "C" and install cotter pin (32).

Door Thickness	Hole
1 3/8"	"A"
1 3/4"	"B"
2"	"B"
Requires regular parts, assembled to order.	

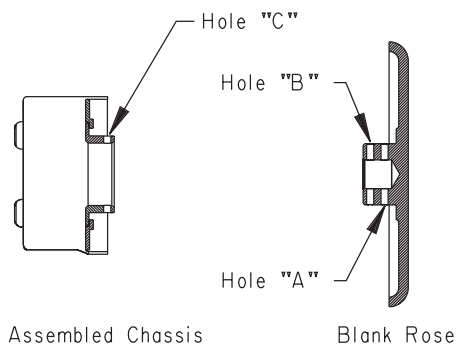

Hub In Assembled Chassis

Blank Rose

## AL40S

### CHASSIS ASSEMBLY

SEE PAGE 23  
FOR INSTALLATION  
INSTRUCTIONS

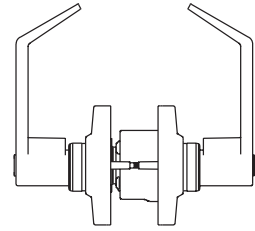
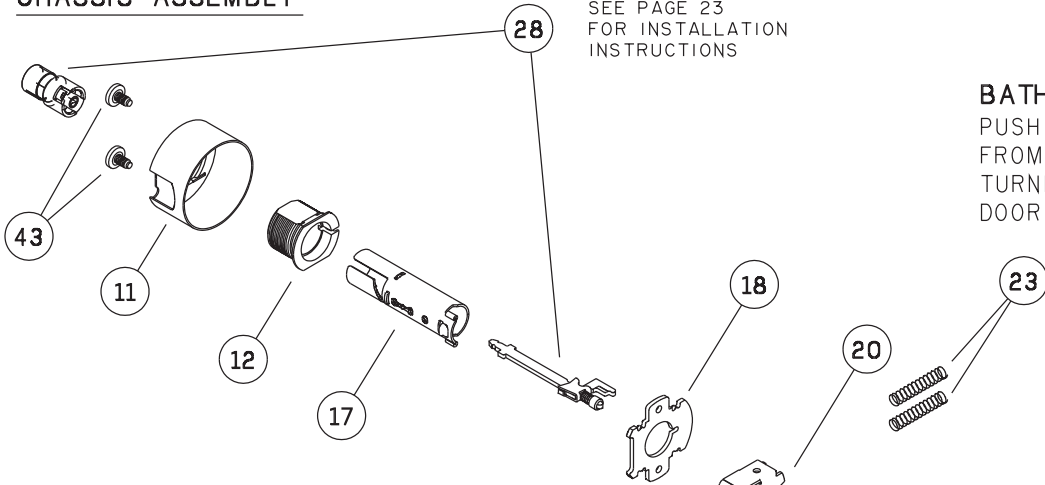

### BATH/BEDROOM LOCK

PUSH BUTTON LOCKING. CAN BE OPENED FROM OUTSIDE WITH SMALL SCREWDRIVER. TURNING INSIDE LEVER OR CLOSING DOOR RELEASES BUTTON.

### TRIM ASSEMBLY

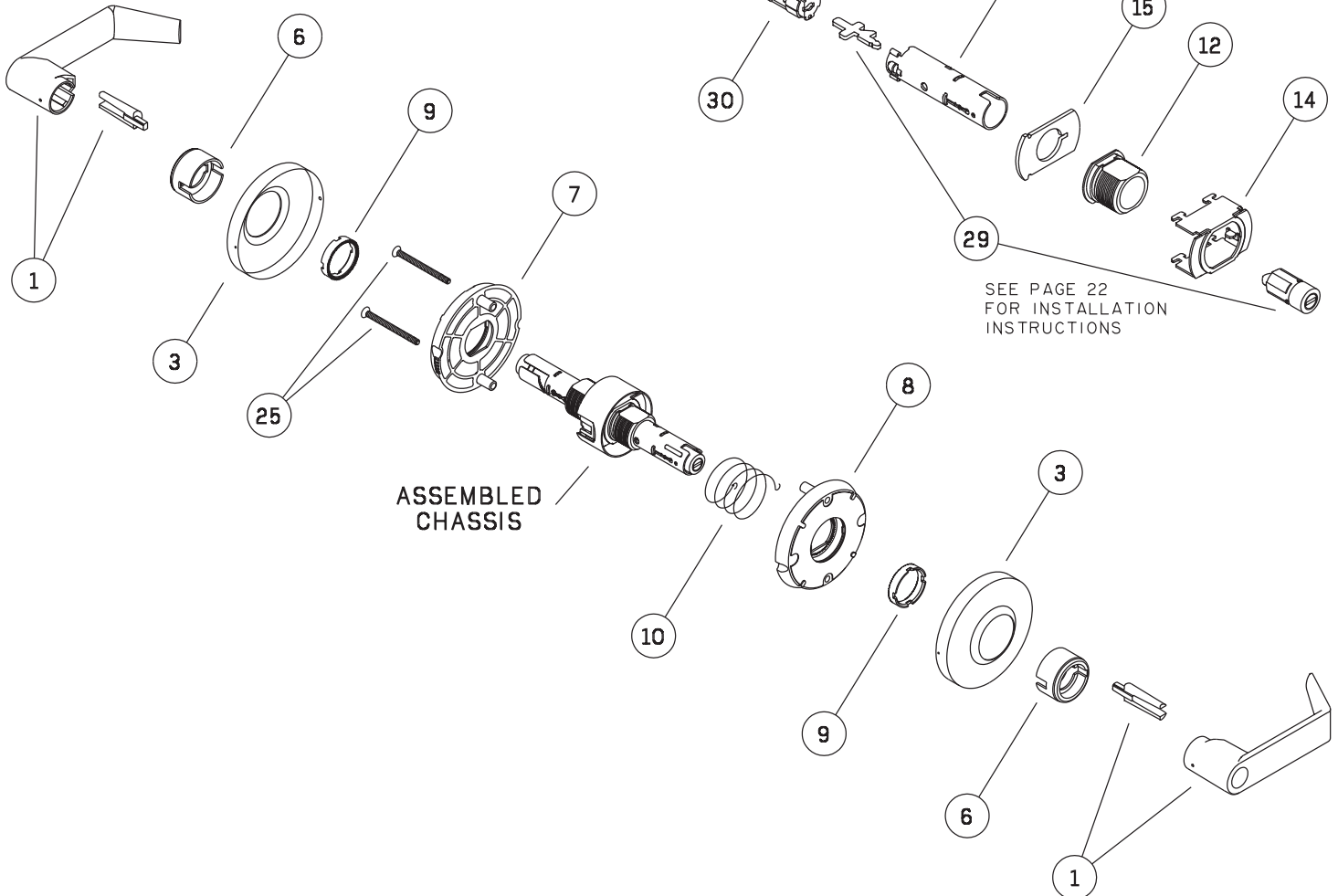

SEE PAGE 22  
FOR INSTALLATION  
INSTRUCTIONS

ASSEMBLED  
CHASSIS

# AL50PD

## CHASSIS ASSEMBLY

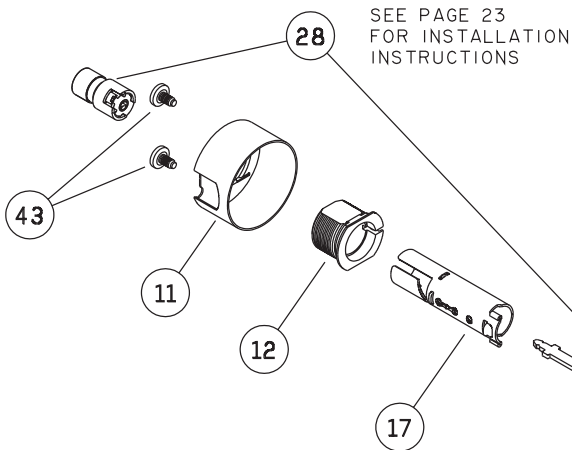

## ENTRANCE LOCK

PUSH-BUTTON LOCKING. PUSH-BUTTON LOCKS OUTSIDE LEVER UNTIL UNLOCKED WITH KEY OR BY ROTATING INSIDE LEVER.

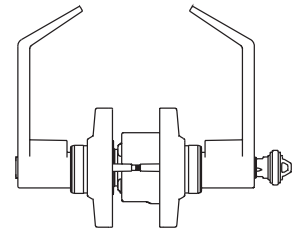

## TRIM ASSEMBLY

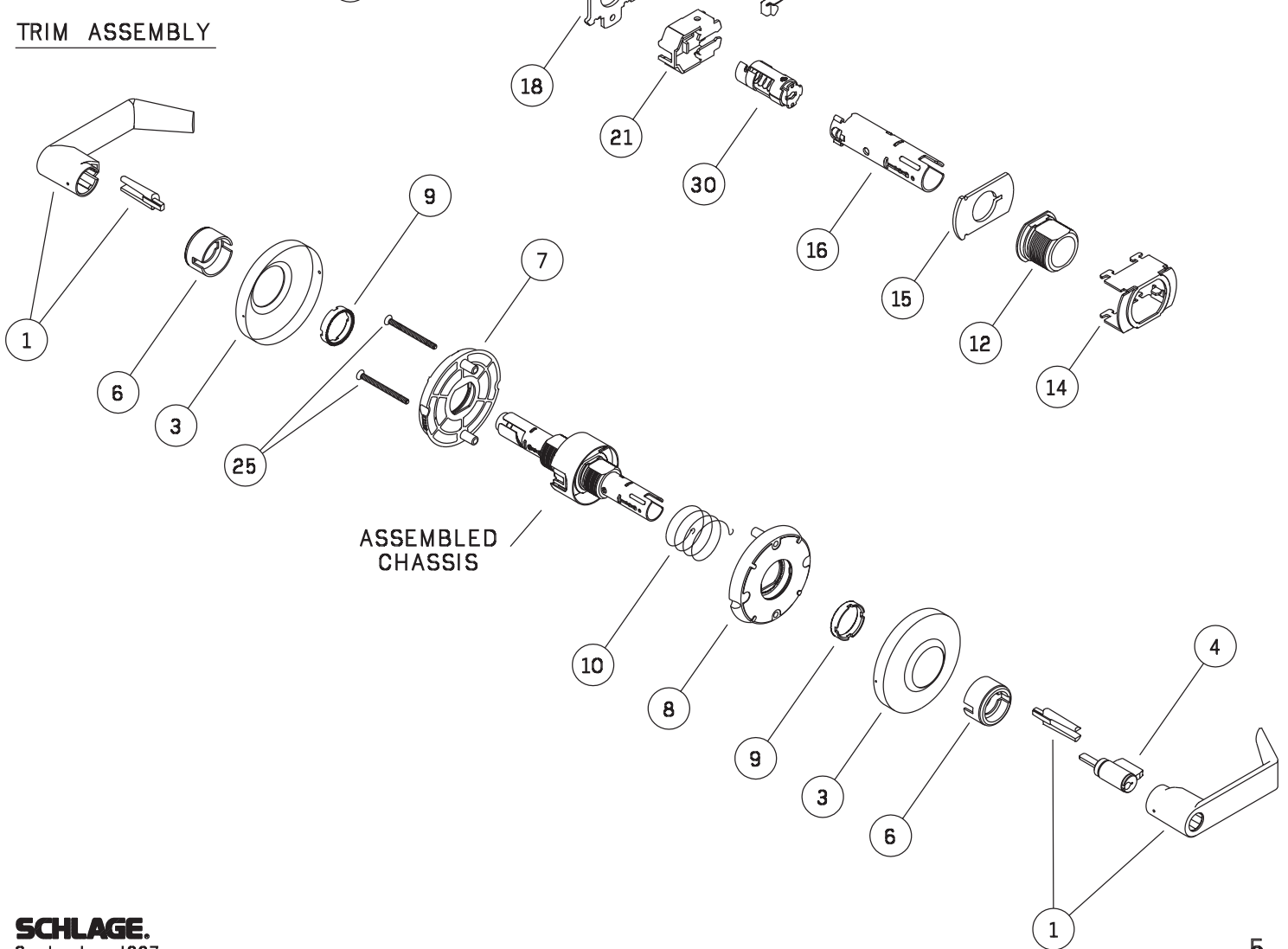

## AL53PD

### CHASSIS ASSEMBLY

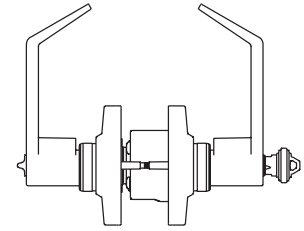
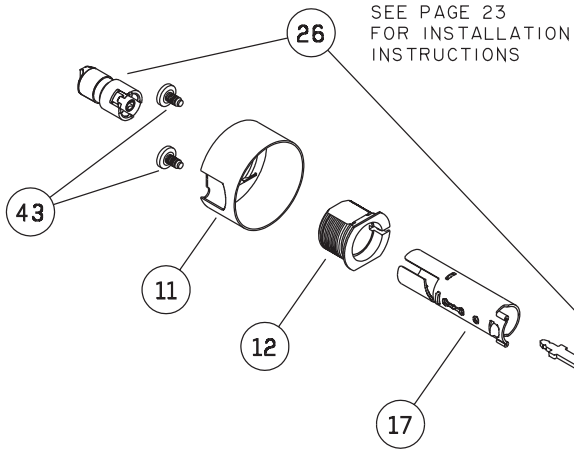

### ENTRANCE LOCK

TURN/PUSH-BUTTON LOCKING:  
 PUSHING AND TURNING BUTTON LOCKS  
 OUTSIDE LEVER REQUIRING USE OF KEY  
 UNTIL BUTTON IS MANUALLY UNLOCKED.  
 PUSH-BUTTON LOCKING:  
 PUSHING BUTTON LOCKS OUTSIDE  
 LEVER UNTIL UNLOCKED BY KEY  
 OR BY TURNING INSIDE LEVER.

### TRIM ASSEMBLY

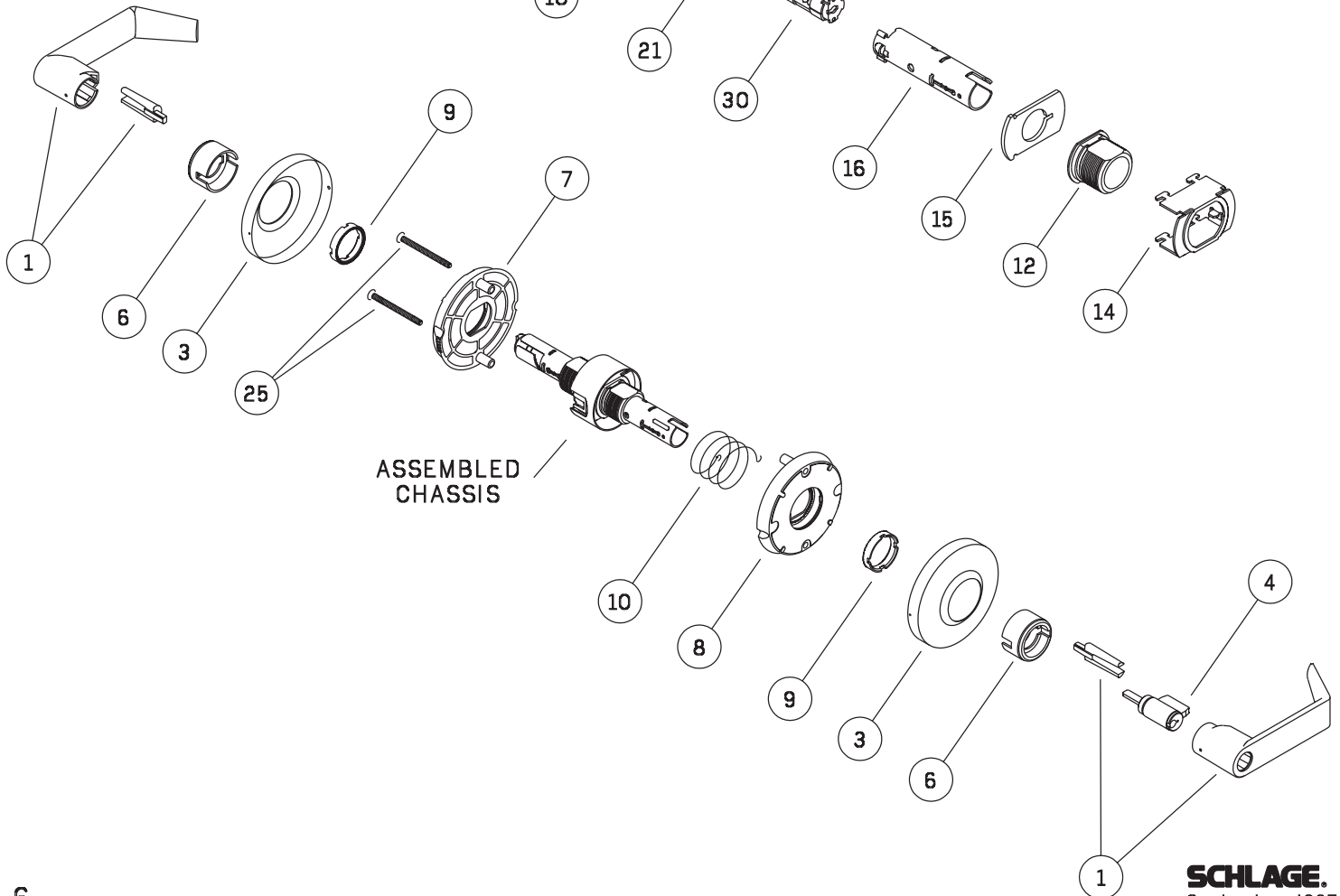

ASSEMBLED CHASSIS



# AL70PD

## CHASSIS ASSEMBLY

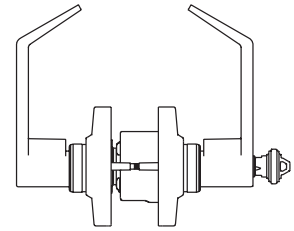

### CLASSROOM LOCK

OUTSIDE LEVER LOCKED AND UNLOCKED BY KEY. INSIDE LEVER ALWAYS UNLOCKED.

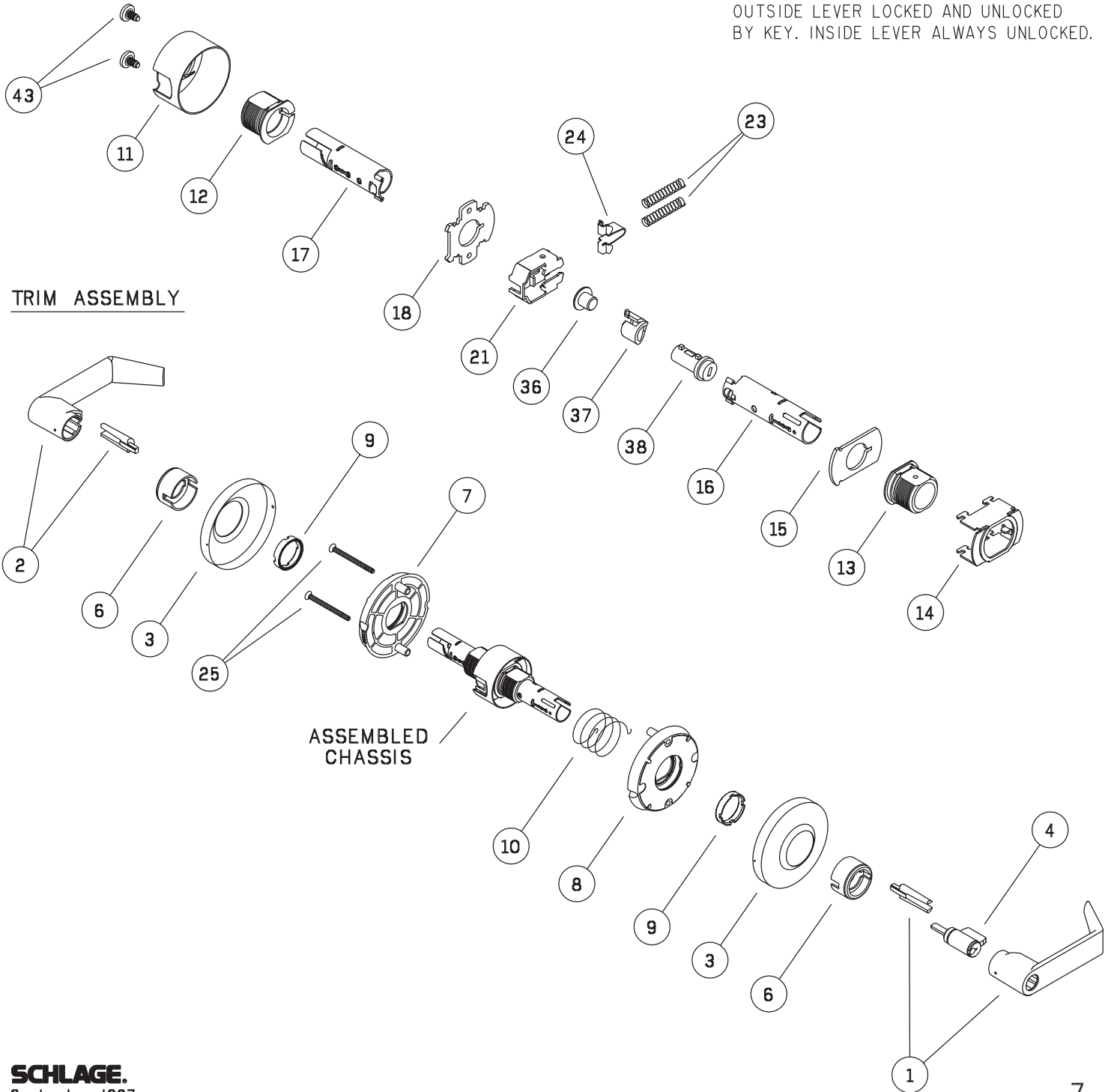

## AL80PD

### CHASSIS ASSEMBLY

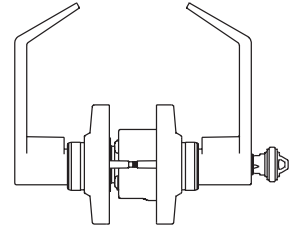

### STOREROOM LOCK

OUTSIDE LEVER FIXED. ENTRANCE BY KEY ONLY. INSIDE LEVER ALWAYS UNLOCKED.

### TRIM ASSEMBLY

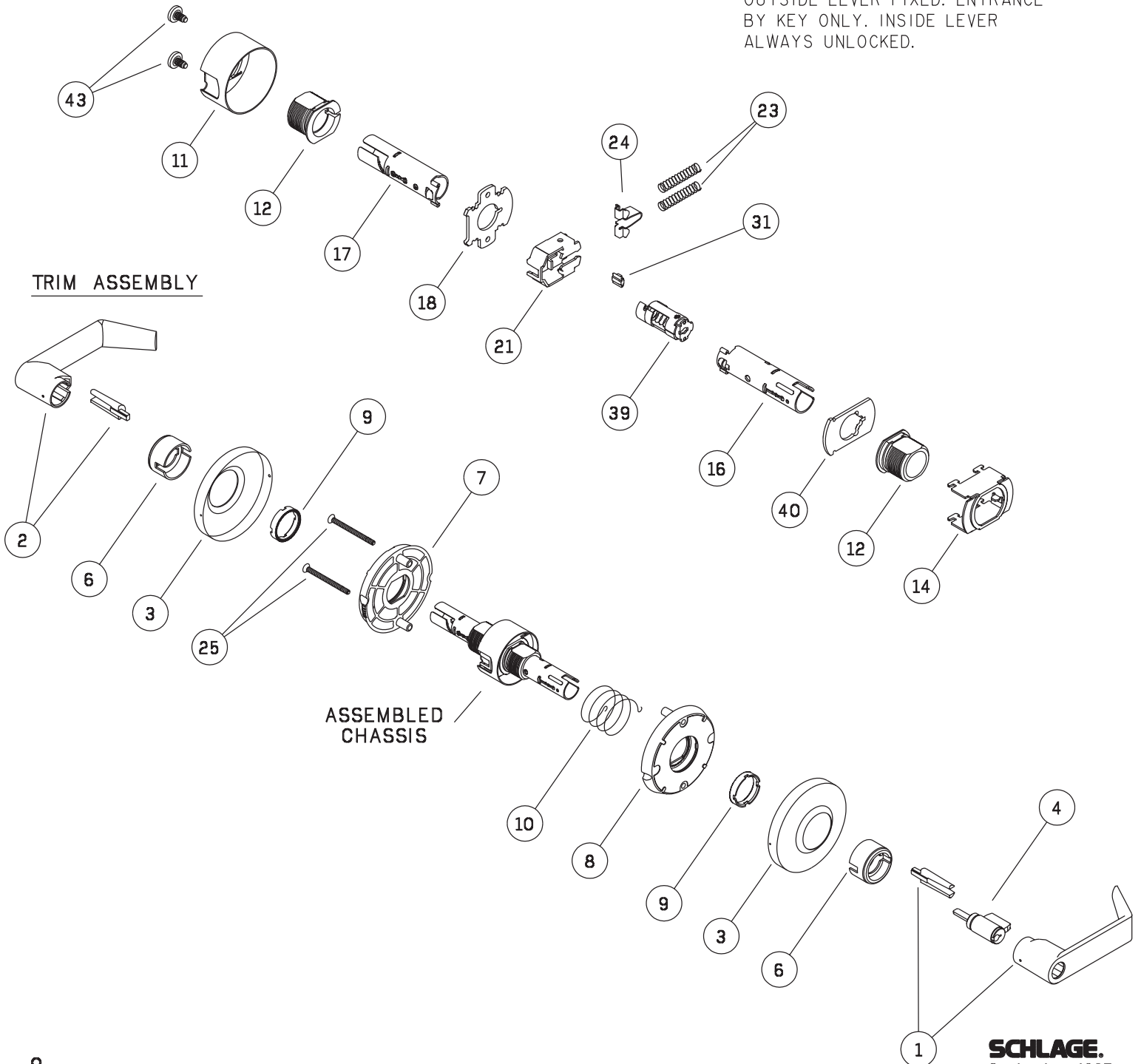

# AL85PD

## CHASSIS ASSEMBLY

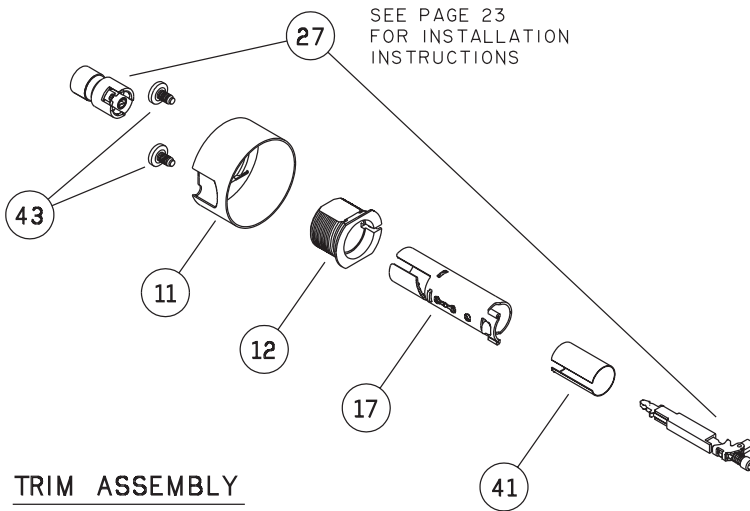

SEE PAGE 23  
FOR INSTALLATION  
INSTRUCTIONS

## TRIM ASSEMBLY

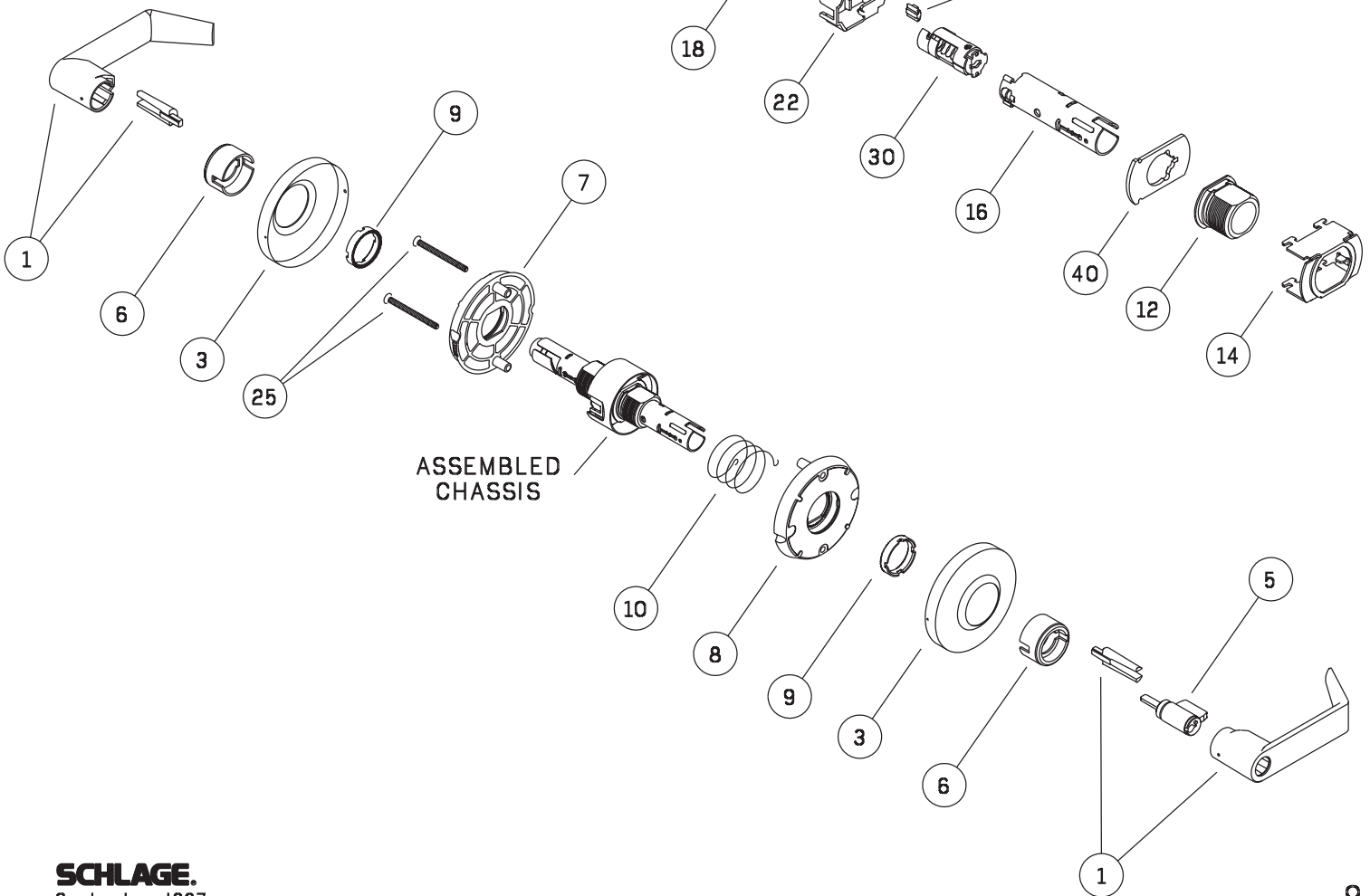

ASSEMBLED  
CHASSIS

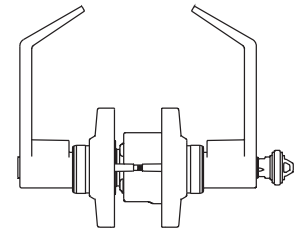

## HOTEL/MOTEL LOCK

OUTSIDE LEVER FIXED. ENTRANCE BY KEY ONLY. PUSH-BUTTON IN INSIDE LEVER ACTIVATES VISUAL OCCUPANCY INDICATOR, ALLOWING ONLY EMERGENCY MASTERKEY TO OPERATE. ROTATING INSIDE LEVER OR CLOSING DOOR RELEASES VISUAL OCCUPANCY INDICATOR. ROTATION OF INSIDE SPANNER BUTTON PROVIDES LOCKOUT FEATURE BY KEEPING INDICATOR THROWN.

## AL170

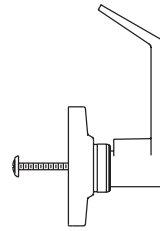

### SINGLE DUMMY TRIM

SINGLE DUMMY TRIM FOR ONE SIDE OF DOOR. USED FOR DOOR PULL OR AS MATCHING INACTIVE TRIM.

Symbol	Number	Description
A	51-021	Lever & Insert
B	A700-009	Driver, Lever
C	04-060	Rose
D	L583-133	Sheet Metal Screw #8 x 1" (2 Required)
E	A710-007	Spindle & Hub
F	C604-400	Mounting Plate
G	A501-171	Washer
H	A501-746	Thru Bolt
I	A501-167	Threaded Rod (For Back to Back Mounting)

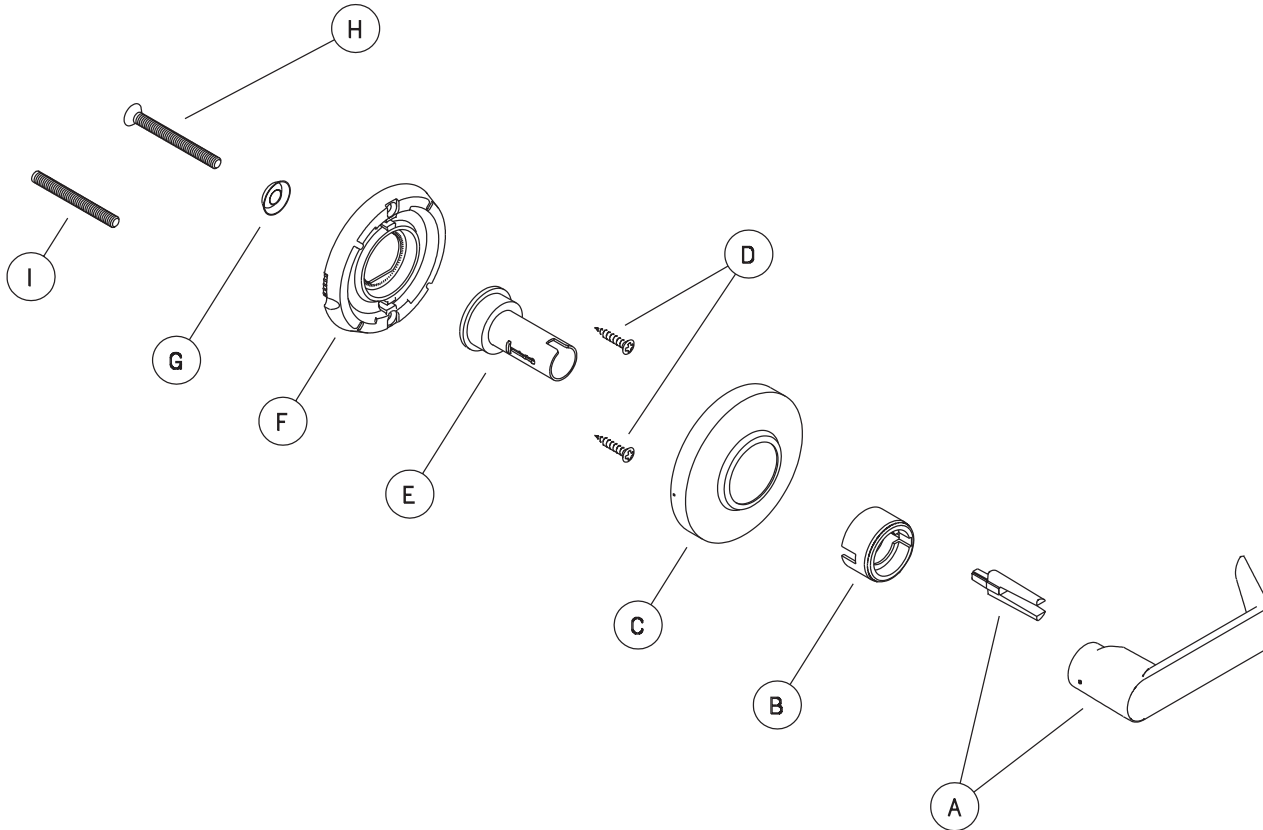

SYMBOL NUMBER	DESCRIPTION								
		AL10S	AL25D	AL40S	AL50PD	AL53PD	AL70PD	AL80PD	AL85PD
①	5I-023** LEVER & INSERT, OPEN			2	2	2	☉	☉	2
②	5I-021** LEVER & INSERT, CLOSED	2	☉				☉	☉	
③	04-060* ROSE	2	☉	2	2	2	2	2	2
④	2I-020* CYLINDER				☉	☉	☉	☉	
⑤	2I-021* CYLINDER, INDICATOR								☉
⑥	A700-009* DRIVER, LEVER	2	☉	2	2	2	2	2	2
	A700-010* DRIVER, LEVER, 2" THICK DOORS	2	☉	2	2	2	2	2	2
⑦	A710-011 SPRING CAGE, INSIDE	☉	☉	☉	☉	☉	☉	☉	☉
⑧	A710-012 SPRING CAGE, OUTSIDE	☉		☉	☉	☉	☉	☉	☉
⑨	C604-354 CASTLE NUT	2	☉	2	2	2	2	2	2
⑩	C503-308 SPRING, ANCHOR	☉		☉	☉	☉	☉	☉	☉
⑪	A700-007 HOUSING	☉	☉	☉	☉	☉	☉	☉	☉
⑫	A700-005 HUB	2	☉	2	2	2	☉	2	2
	A700-028 HUB, 2" THICK DOORS	2	☉	2	2	2	☉	2	2
⑬	A700-014 HUB, OUTSIDE						☉		
	A700-029 HUB, OUTSIDE, 2" THICK DOORS						☉		
⑭	A700-006 FRAME, HUB	☉	☉	☉	☉	☉	☉	☉	☉
⑮	A700-004 PLATE, HUB, OUTSIDE	☉		☉	☉	☉	☉		
⑯	A710-001 SPINDLE & CATCH, OUTSIDE				☉	☉	☉	☉	☉
⑰	A710-004 SPINDLE & CATCH, INSIDE	☉	☉	☉	☉	☉	☉	☉	☉
⑱	A50I-305 PLATE, HUB, INSIDE	☉	☉	☉	☉	☉	☉	☉	☉
⑲	A590-181 SLIDE, NON-RESTORING	☉	☉						
⑳	A590-180 SLIDE, RESTORING			☉					
㉑	A590-159 SLIDE, NON-RESTORING				☉	☉	☉	☉	
㉒	A590-158 SLIDE, 85								☉
㉓	A50I-311 SPRING, SLIDE	2	2	2	2	2	2	2	2
㉔	A508-597 SEAT, SPRING				☉	☉	☉	☉	☉
㉕	C604-395 MOUNTING SCREW	2		2	2	2	2	2	2
㉖	5I-037* PLUNGER & BUTTON, INSIDE					☉			

\* SPECIFY FINISH.  
 \*\* SPECIFY DESIGN AND FINISH.

SYMBOL NUMBER	DESCRIPTION	AL10S	AL25D	AL40S	AL50PD	AL53PD	AL70PD	AL80PD	AL85PD
27	5I-038* PLUNGER & BUTTON, INSIDE								●
28	5I-039* PLUNGER & BUTTON, INSIDE		●	●					
29	5I-040* PLUNGER & BUTTON, OUTSIDE		●						
30	A30I-402 CAM		●	●	●				●
31	A50I-6I5 WEDGE, SPINDLE						●	●	
32	C604-273 COTTER PIN, OUTSIDE ROSE	●							
33	C604-402* ROSE, BLANK, OUTSIDE	●							
34	A50I-874 PLATE, HUB, OUTSIDE	●							
35	A700-0I6 HUB, OUTSIDE	●							
	A700-030 HUB, OUTSIDE, 2" THICK DOORS	●							
36	A50I-79I SPACER, CAM					●			
37	A700-0I7 CAM, SPIRAL					●			
38	A50I-72I PLUG, CAM					●			
39	A20I-370 CAM						●		
40	A50I-90I PLATE, HUB, OUTSIDE						●	●	
4I	A700-003 SLEEVE, SPINDLE								●
42	A7I0-020 SPINDLE & CATCH, OUTSIDE	●	●						
43	A700-032 SCREW, CHASSIS	2	2	2	2	2	2	2	2

\* SPECIFY FINISH.

**DESIGNS** Order by design code shown in parenthesis ( ).

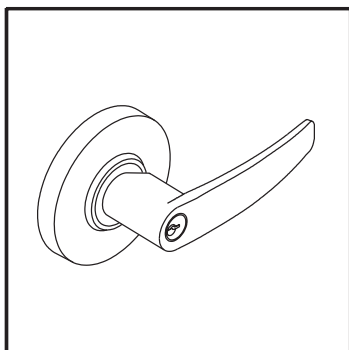

Jupiter (JUP)

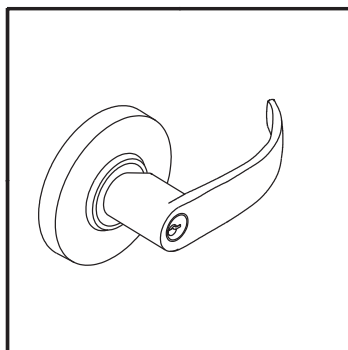

Neptune (NEP)

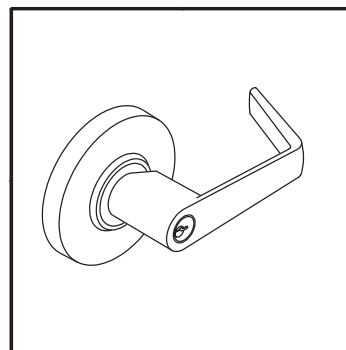

Saturn (SAT)

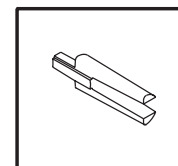

A700-015  
Standard  
Lever insert

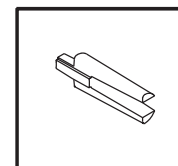

A700-034  
Lever insert,  
2" doors

## FINISHES

Schlage Lock finishes are durable, top quality finishes obtained by the careful processing of solid brass, bronze, stainless steel or other materials. Where required, a protective clear coating is applied and cured under high temperature. It is important that climatic conditions and usage be taken under consideration when selecting finishes. This is especially true in areas subjected to strong corrosive vapors, humid climate or sea air, which, in a short time, may have a damaging effect on metal finishes.

The longevity and preservation of the finish appearance is determined by base metal and finishing process. Clear protective coating or other organic finishing applications may require different methods of cleaning and care. As an example, non-clear coated finishes should not be cleaned with soaps or any solvents; organically coated surfaces should periodically be cleaned with a mild non-abrasive soap and buffed lightly with a clean cloth. The type of base metal and finishing techniques must be considered when applying any cleaning or preservative method. Contact the Schlage Technical Services Department for further information on the care of finished hardware.

In some instances for customer convenience, the most appropriate BHMA finish symbols are used to indicate similarity of appearance regardless of base metal or finishing process. AL-Series levers are zinc-based material and are plated to match finishes indicated. Finish numbers in the 600 Series are the BHMA (Builders Hardware Manufacturers Association) industry standard. The nearest old U.S. equivalent code designations are shown in parenthesis ( ).

Symbol	Description
605 (3)	BRIGHT BRASS Clear Coated
606 (4)	SATIN BRASS Clear Coated
609 (5)	SATIN BRASS, BLACKENED Satin Relieved, Clear Coated
612 (10)	SATIN BRONZE Clear Coated
613 (10B)	OIL RUBBED BRONZE Oxidized Satin Bronze, Oil Rubbed, No Coating
625 (26)	BRIGHT CHROMIUM PLATED No Coating
626 (26D)	SATIN CHROMIUM PLATED No Coating

## LUBRICATION

AL-Series lock mechanisms are designed for durability and seldom need servicing. During assembly, those points of contact which require lubrication for ease of operation are given an application of high quality petroleum based grease. A touch of graphite is applied to the pin tumbler plug during assembly of the cylinder unit. No further servicing should be required for an extended period except where locks are subjected to extremely heavy traffic. Also, if located in particularly dusty or dirty areas, the grease may become contaminated resulting in a slow or otherwise unsatisfactory operation. The case mechanism should then be cleaned in a noncorrosive petroleum solvent and relubricated. Graphite only should be applied to the cylinder unit by blowing a small quantity into the keyway.

**Note:** Precautionary measures according to solvent manufacturers instructions should always be followed.

## TACTILE WARNING

Tactile warning is achieved by milling three (3) grooves on the inside surface of the AL-Series lever. This is the means of identifying hazardous areas, such as electrical closets and mechanical equipment, for the visually impaired. Tactile warning is available on all AL-Series designs. When ordering specify if both sides, outside or inside levers require tactile warning. Order by specifying design code 8JU (Jupiter), 8NE (Neptune) or 8SA (Saturn).

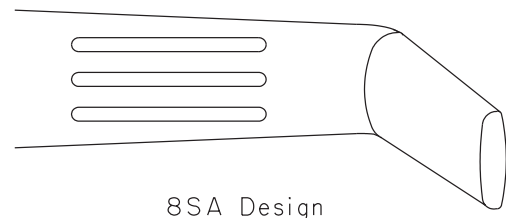

## CYLINDER UNITS AND PARTS

Schlage locks are provided with cylinder units precision built to extremely close tolerances and the highest standards of accuracy. Phosphor bronze springs, nickel silver keys and pins are used throughout the Schlage offering. The best combination of materials is used to ensure the manufacture of cylinders with ease of operation and long wear. To order locks less cylinder units, change product suffix letter "P" to "L". Example: AL53LD. Primus<sup>®</sup> cylinders are available when key control and physical security are important concerns.

### CYLINDER UNITS

Standard Cylinders	Primus Cylinders		Description	Design
	High Security	Controlled Access		
2I-020	20-528	20-728	6 Pin unit	JUP, NEP, SAT
2I-02I	Not Available		6 Pin indicator unit (AL85)	

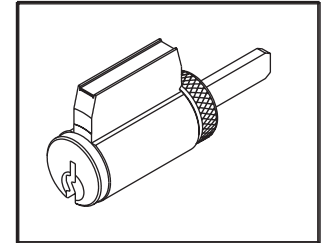

**21-020**  
Standard Cylinder

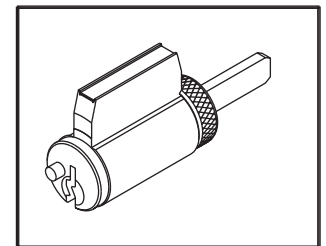

**21-021**  
Hotel Function  
Indicator Cylinder

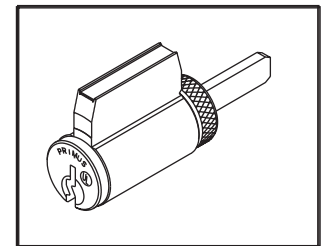

**20-528**  
Primus High Security  
U.L.437 Listed

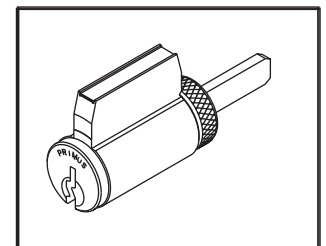

**20-728**  
Primus Controlled Access

### CYLINDER PARTS (Drawings are on page I5)

Symbol	Number	Description
A	33-006	Cylinder plug, 6 pin
B	33-216	Cylinder plug, indicator, 6 pin
C	34-101 thru 103	#1 thru #3 Top pin
D	34-202 thru 209	#2 thru #9 Master pin
E	34-300 thru 309	#0 thru #9 Bottom pin
F	A201-849	Body, 6 pin
G	A700-031	Bar & driver for 2I-020
H	A700-023	Bar for 2I-02I
I	C503-113	Tumbler spring
J	C503-115	Retainer cap spring
K	C503-116	Retainer cap pin
L	C503-118	Retainer cap
M	C503-767	Driver for 2I-02I
N	C603-195	Obstruction pin for 2I-02I
O	C604-144	Indicator pin spring for 2I-02I
P	C604-371	Indicator pin for 2I-02I

#### Important:

Use only graphite or similar material for cylinder lubrication. Under no circumstance should any other type of material be introduced into the cylinder.



STANDARD CYLINDER

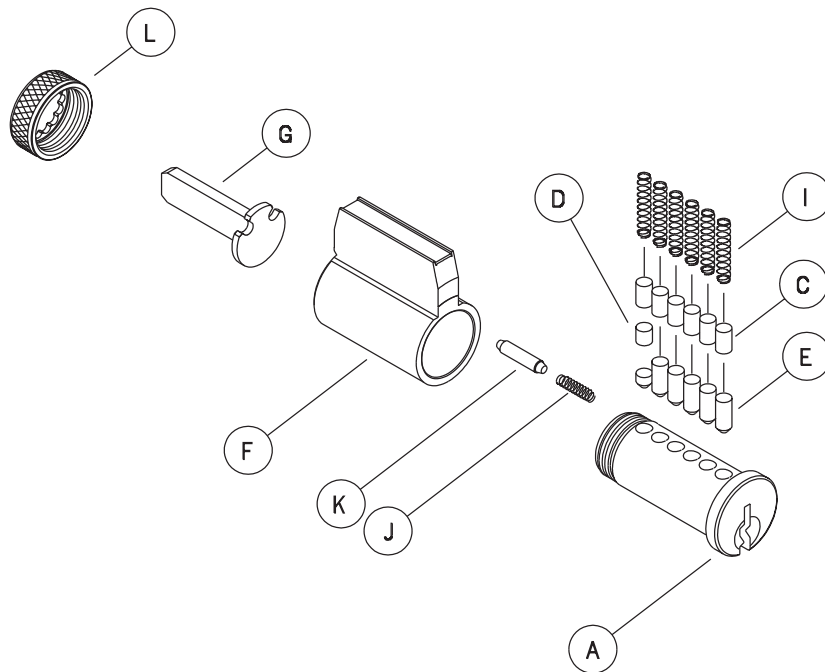

HOTEL FUNCTION INDICATOR CYLINDER

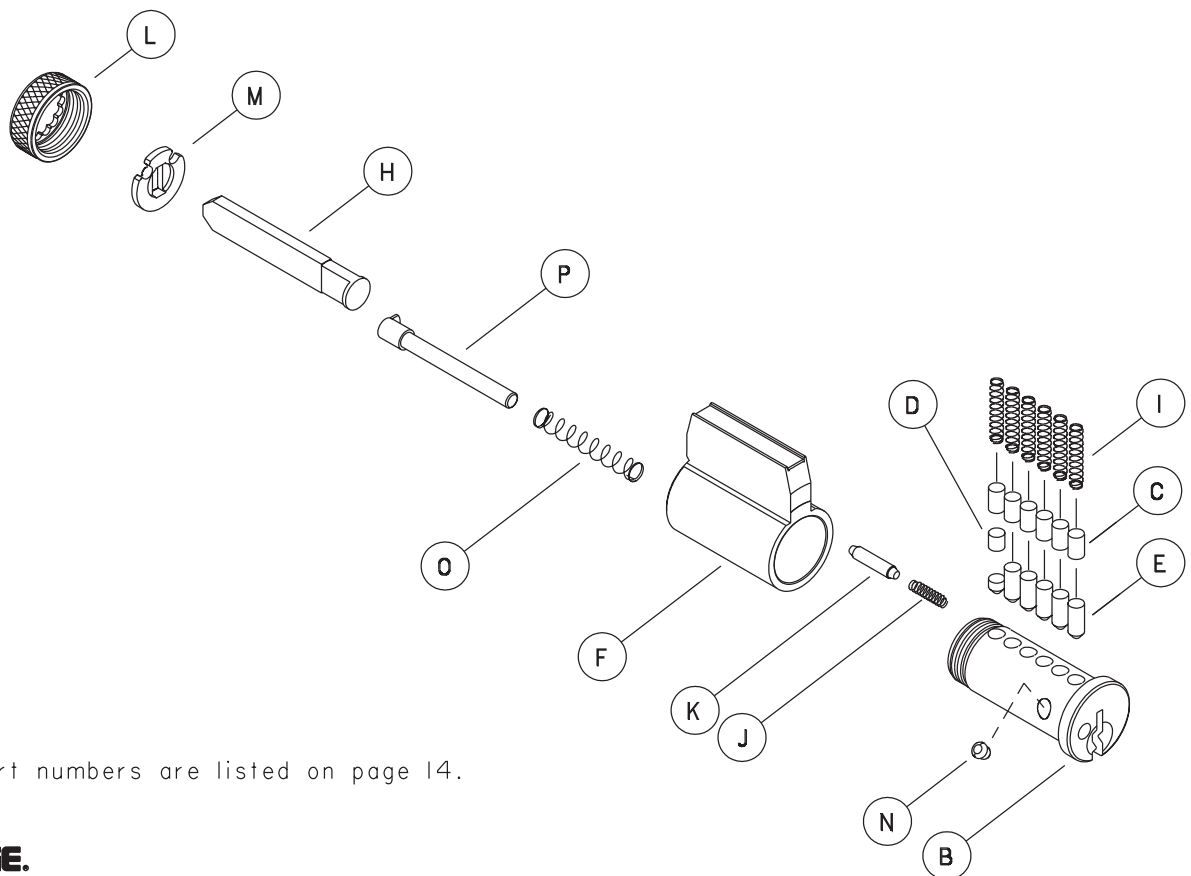

Note: Part numbers are listed on page 14.

## INTERCHANGEABLE CORES, DESIGN AND PARTS

Available in Saturn design for all AL-Series keyed functions, except Hotel/Motel function AL85, as complete locks or in retrofit kits. Existing installations can be retrofit without removing lock from door. To order locks with interchangeable cores, change product suffix letter "P" to "R". Example: AL53RD. To order locks less interchangeable cores, change product suffix letter "P" to "J". Example: AL53JD. Primus® cores are available when key control and physical security are important concerns.

### INTERCHANGEABLE CORES

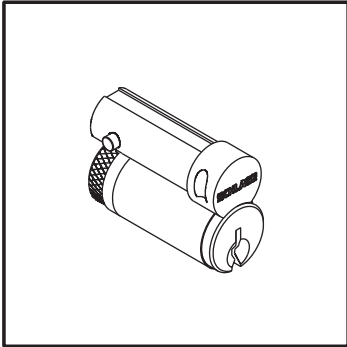

**23-030**  
Interchangeable Core w/logo

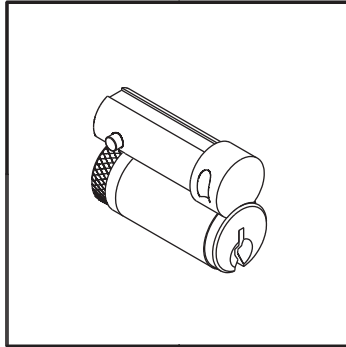

**23-031**  
Interchangeable Core w/o logo

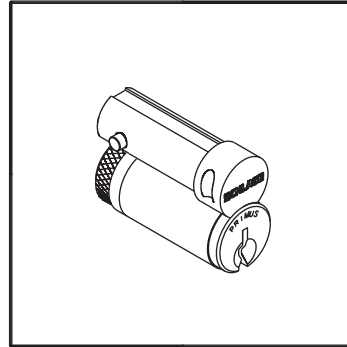

**20-740**  
Primus Interchangeable Core, w/logo, Controlled Access

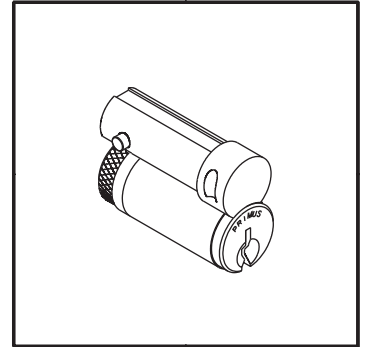

**20-741**  
Primus Interchangeable Core, w/o logo, Controlled Access

### INTERCHANGEABLE CORE DESIGN

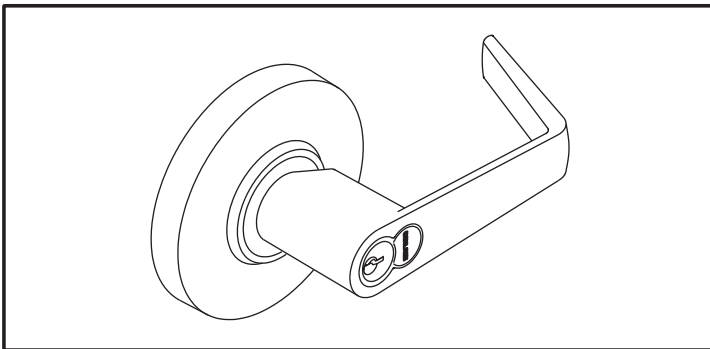

Saturn

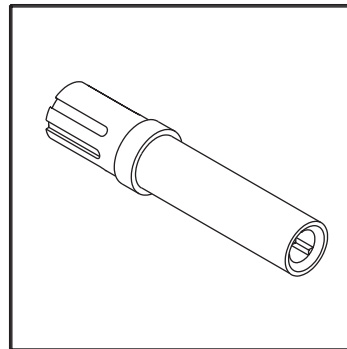

**M504-142 Installation Tool**  
Order as needed per project.

### INTERCHANGEABLE CORE ACCESSORY AND SERVICE PARTS

Number	Description
01-025	Lever & insert, driver and retainer
01-054	Lever & insert, core, driver and retainer
01-126	Driver and retainer
20-740	Primus interchangeable core w/logo
20-741	Primus interchangeable core w/o logo
23-030	Interchangeable core w/logo
23-031	Interchangeable core w/o logo
51-022	Lever & insert
A700-008	Lever insert, Standard
A700-019	Driver
A700-033	Lever insert, 2" doors
M504-142	Installation tool
S605-241	Retainer

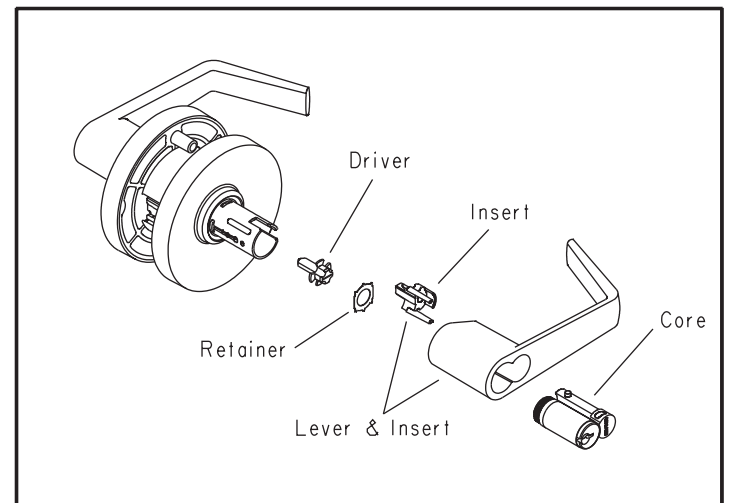

**01-054 Retrofit Kit**  
(See page 26 for retrofit kit instructions)

## INTERCHANGEABLE CORE

To remove interchangeable core, insert control key and turn 15° to the right until action stops. Pulling on key will extract core from the knob. To install a new core, insert control key and and push core into housing, rotate key 15° to the right and insert core completely. Rotate key back to original position and remove control key.

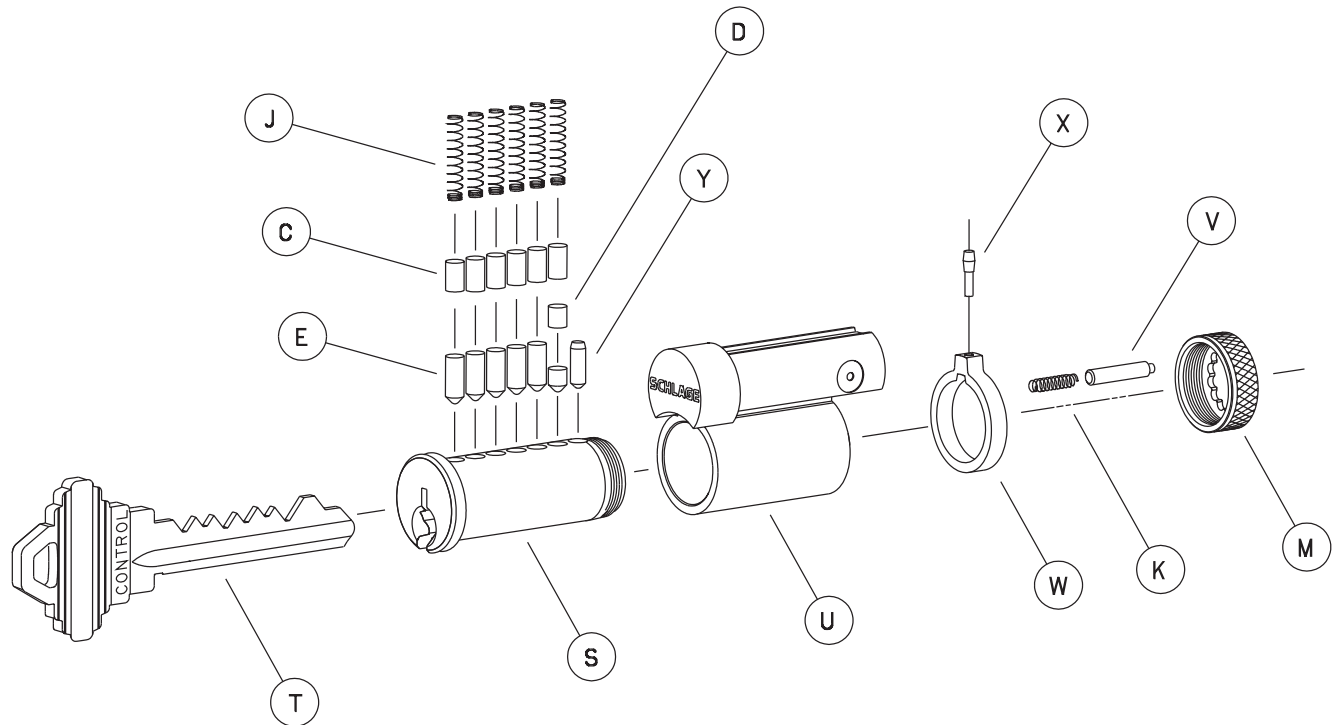

## INTERCHANGEABLE CORE PARTS

Symbol	Number	Description
C	34-101 thru 103	#1 thru #3 Top pin
D	34-202 thru 209	#2 thru #9 Master pin
E	34-300 thru 309	#0 thru #9 Bottom pin
J	C503-113	Tumbler spring
K	C503-115	Retainer cap spring
M	C503-118	Retainer cap
S *	33-058	Plug, interchangeable core
T	35-056	Control key, blank
	48-056	Control key, cut
U *	B220-282	Interchangeable core body, w/logo
	B220-283	Interchangeable core body, w/o logo
V	C603-347	Retainer cap pin
W *	C603-956	Actuating ring
X *	C603-964	Actuating pin
Y *	C603-967	Control pin

\* Parts not compatible with cores manufactured before 1991.

### Important:

Use only graphite or similar material for cylinder lubrication. Under no circumstance should any other type of material be introduced into the cylinder.

## LATCHES

All AL-Series latches have adjustable faceplates for flat or beveled doors, except circular drive-in latches.

### Square Corner Latches

### Round Corner Latches

### Drive-in Latches

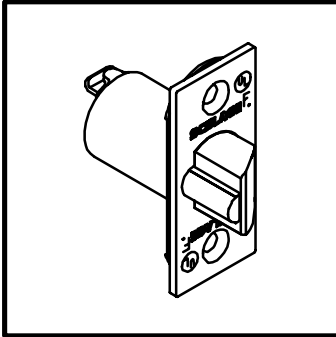

Deadlatch

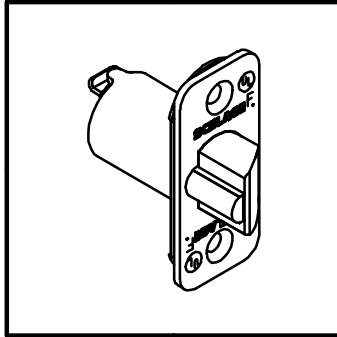

Deadlatch

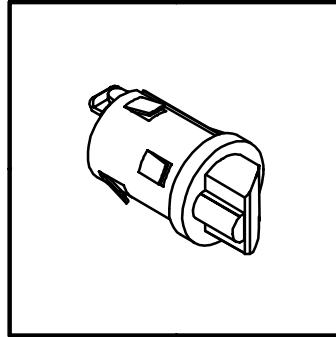

Deadlatch

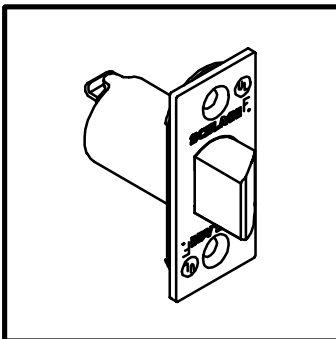

Springlatch

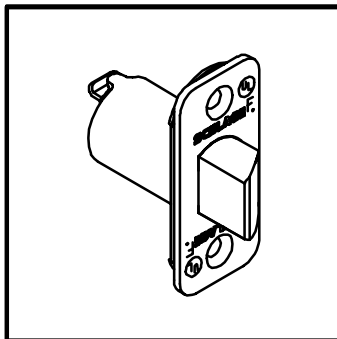

Springlatch

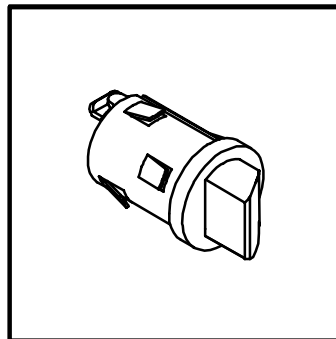

Springlatch

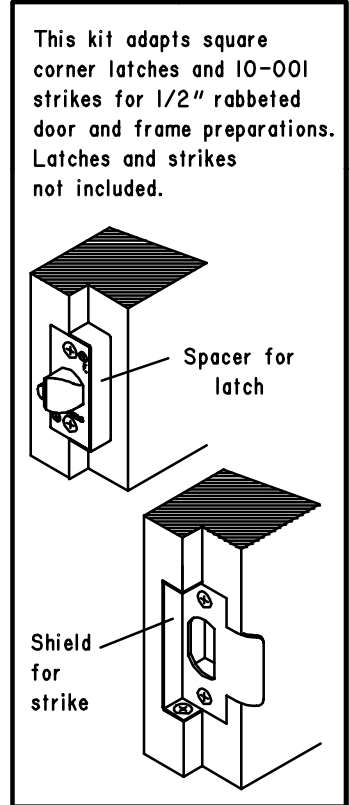

This kit adapts square corner latches and 10-001 strikes for 1/2" rabbeted door and frame preparations. Latches and strikes not included.

**39-030**  
Rabbeted Latch and Strike Kit

## LATCHES

Backset	Faceplate Description	Deadlatch 1/2" Throw	Springlatch 1/2" Throw	Housing Diameter
2 3/8"	1" x 2 1/4", Square corner	11-085	11-068	7/8"
	1" x 2 1/4", 1/4" Radius round corner	11-088	11-069	7/8"
	1" Circular, drive-in (non-U.L.)	11-104	11-110	1"
2 3/4"	1" x 2 1/4", Square corner	11-091	11-111	7/8"
	<b>1 1/8" x 2 1/4", Square corner, standard</b>	<b>11-096</b>	<b>11-116</b>	<b>1"</b>
	1" x 2 1/4", 1/4" Radius round corner	11-092	11-112	7/8"
3 3/4"	1" Circular, drive-in (non-U.L.)	11-105	11-113	1"
	1 1/8" x 2 1/4", Square corner	11-103	11-118	1"
—	Rabbeted latch and strike kit	39-030		

**STRIKES**

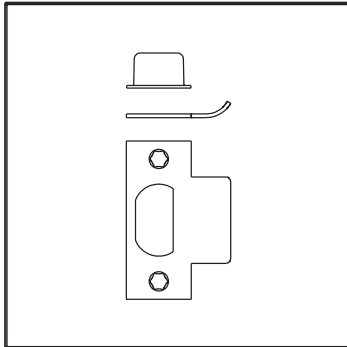

**10-001**  
 Square Corner  
 Size: 1 1/8" x 2 3/4" x 3/32"  
 Lip Length: 1 1/8" (Std), 1",  
 1 1/4", 1 1/2", 1 3/4", 2"  
 Includes C603-623 strike box.

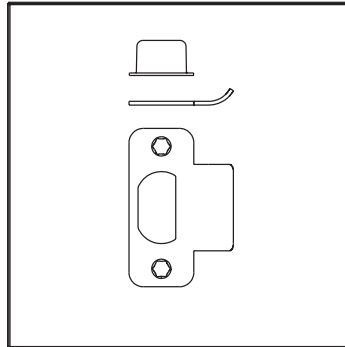

**10-004**  
 1/4" Radius Round Corner  
 Size: 1 1/8" x 2 3/4" x 3/32"  
 Lip Length: 1 1/8"  
 Includes C603-623 strike box.

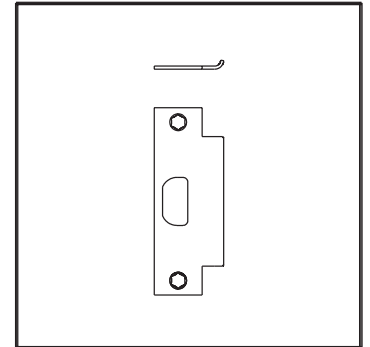

**10-025 (Standard)**  
 ANSI Prep. A115.2  
 Size: 1 1/4" x 4 7/8" x 3/32"  
 Lip Length: 1 3/16" (Std), 1 3/8",  
 If required, K510-066 strike  
 box must be ordered separately.

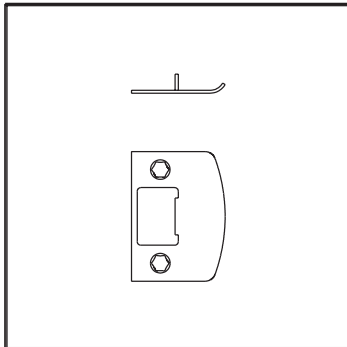

**10-026**  
 Full Lip, Square Corner  
 Size: 1 5/8" x 2 1/4" x 1/16"  
 Lip Length: 1 1/8"

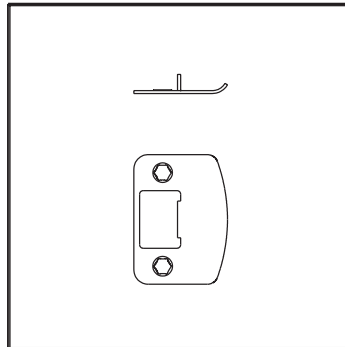

**10-027**  
 Full Lip, 1/4" Radius Round Corner  
 Size: 1 5/8" x 2 1/4" x 1/16"  
 Lip Length: 1 1/8"

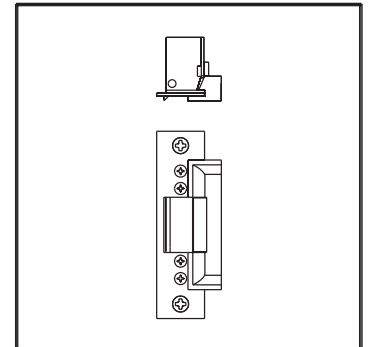

**10-042**  
 Electric Strike  
 Size: 1 1/4" x 4 7/8" x 3/32"  
 Voltage: 24VAC, 12VDC  
 Not designed for continuous  
 duty and electrical locking.

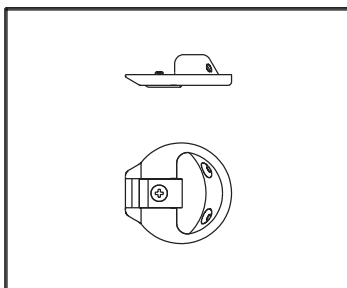

**10-058**  
 Circular Adjustable  
 Size: 1 3/4" Diameter  
 Lip Length: 1 7/32"

**Optional Tamper Resistant Torx Screw Packs**

Number	Description
C203-311	(4) Latch and Strike Screws, #8-32 x 1/2" (T-15)
C203-312	(2) Latch Screws, #8-32 x 1/2" (T-15) (2) ANSI Strike Screws, #12-24 x 1/2" (T-20)

**Torx Tools**

Number	Description
M504-425	T-15 Torx Tool
M504-426	T-20 Torx Tool

## INSTALLATION TOOLS AND KITS

Boring jigs and tools are designed to provide fast and accurate lock installation. Complete kits, contained in a heavy gage metal box, or individual tools can be ordered for preparing doors and jambs for Schlage products.

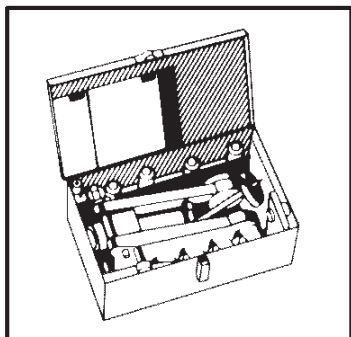

**40-055**  
Installation Kit  
For A, AL, D and F-Series Locks. Adjustable for 2 3/8", 2 3/4" and 5" backsets, Removable bushing adaptor for 7/8" latch hole. The boring jig integrates thru bolt hole locations for AL and D-Series levers. For door thickness 1 3/8" to 2 1/8".

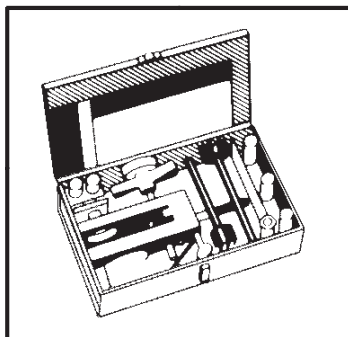

**40-006**  
Installation Kit  
For A, AL, B, D, F, H and S200-Series locks. Adjustable for 2 3/8" and 2 3/4" backsets. Designed for special high speed hexagonal shank boring bits and equipped with an adaptor to form an integrated unit for boring doors 1 5/16" to 1 15/16" thick.

Number	Description
40-056	Boring Jig
40-015	7/8" Boring Bit
40-018	1" Boring Bit
40-024	2 1/8" Boring Bit
40-029	Strike Marking Chisel, Full Lip
40-030	Strike Marking Chisel
40-031	Latch Marking Chisel, A,F,H
40-032	Latch Marking Chisel, B,D,H
40-035	Strike Locator, 7/8"
40-036	Strike Locator, 1"
40-041	4" Bit Extension
40-050	Tool Box
40-057	5/16" Boring Bit
M507-347	Socket Wrench

Number	Description
40-012	Boring Jig
40-016	7/8" Boring Bit
40-019	1" Boring Bit
40-025	2 1/8" Boring Bit
40-026	1 1/2" B-Series Bushing
40-028	1 1/2" Boring Bit
40-029	Strike Mrk. Chisel
40-030	Strike Mrk. Chisel
40-031	Latch Mrk. Chisel
40-032	Latch Mrk. Chisel
40-035	Strike Locator
40-036	Strike Locator
40-039	Boring Bit Adapt.
40-042	Backset Peg
40-049	Tool Box
M504-265	Jig Replacement Bushing

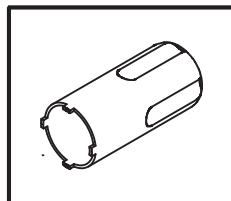

**40-017**  
Castlenut Wrench

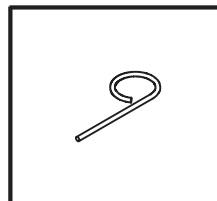

**M504-271**  
Catch Push Pin

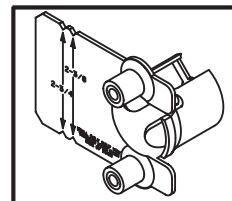

**40-080**  
Drill Fixture  
For thru bolts on AL and D-Series levers.

## LONG BACKSETS

Backsets 5" and over require extension links. AL-Series locks with long backsets are normally furnished with 1" faceplates and 7/8" housings. Links installed in 1" latch holes require one G506-815 sleeve (order separately) to join latch and link. Backsets over 5" require an additional sleeve placed 1/8" from lock chassis. Information on longer backsets is available upon request.

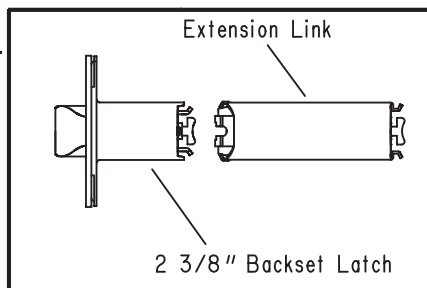

**41-005**  
5" Extension Link

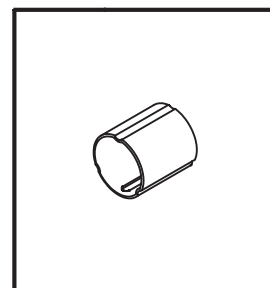

**G506-815**  
Sleeve

## REINFORCEMENT KIT

The Schlage 37-001 reinforcement kit is to reinforce and help prevent the collapse of hollow metal doors when locksets are tightly mounted. This kit should be used with long backsets for installations in hollow metal doors to prevent lateral movement of latch bolt. Specify door thickness 1 3/8" or 1 3/4" when ordering.

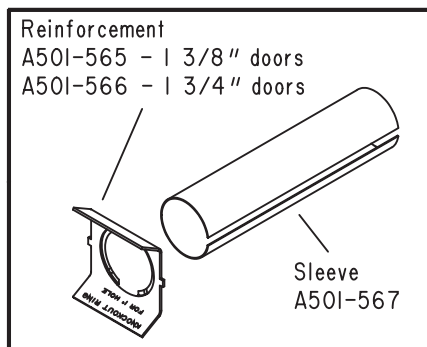

**37-001**  
Reinforcement Kit

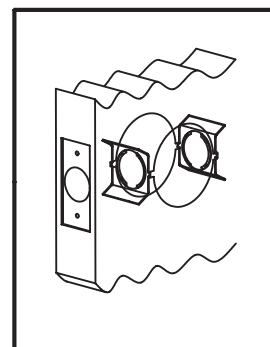

Placement of reinforcements in hollow metal door.

## KEYING

### Key Array Chart

The Schlage Masterkey Department determines and makes the final decision in the selection and use of key sections. Other keyways, than shown below, are available. Allocation of other keyways is based on need and extent of the final system. Priority is given to key systems that require a large number of cylinders and families of key sections to satisfy their keying requirements. Contact your Schlage representative for availability of other keyways.

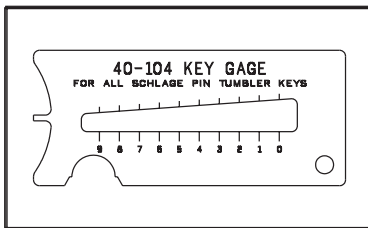
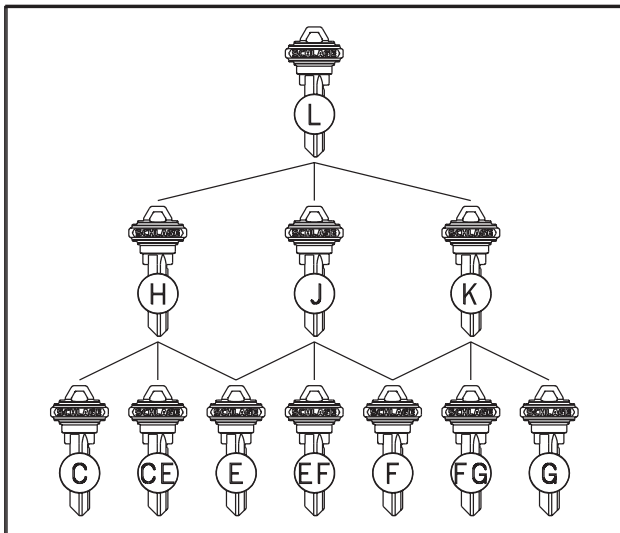

**Key Gage**  
40-104

Order the Schlage key gage to accurately measure the depth of key cuts.

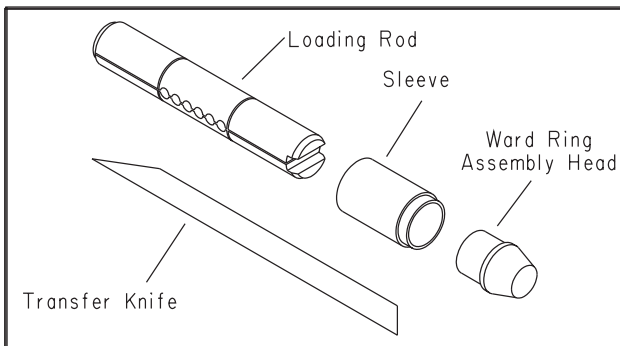

**Cylinder Body Loading Tool**  
40-116

A compact precision tool for loading top pins and springs and for installation of ward rings into grooves of a warded cylinder plug. Furnished with complete assembly instructions.

### Pin Tumbler Keys

All Schlage locks come with two nickel silver keys as standard, embossed with our company logo. The nickel silver alloy from which all Schlage keys are made provides the base for accuracy in cutting and long cylinder wear. Schlage will stamp "DO NOT DUPLICATE" across the bow of all versions of its keys at no extra charge, when specified on orders.

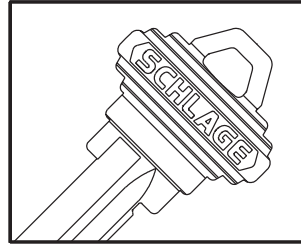

**Embossed Both Sides**  
35-100 (5 Pin standard)  
35-101 (6 Pin)

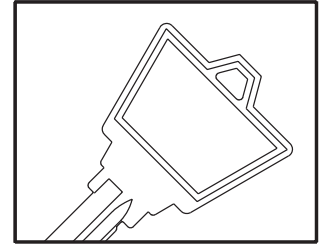

**Large Bow**  
35-140 (5 Pin)  
35-141 (6 Pin)

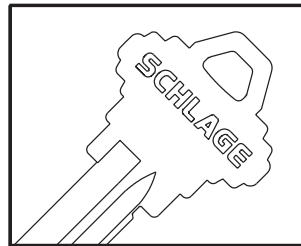

**Stamped One Side**  
35-120 (5 Pin)  
35-121 (6 Pin)

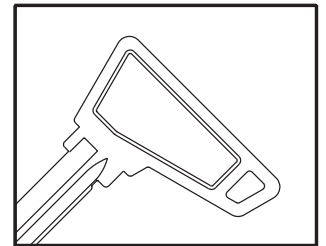

**Access Bow**  
35-143 (5 Pin\*)  
35-144 (6 Pin)  
\*Available in C,E,F, and CE Only

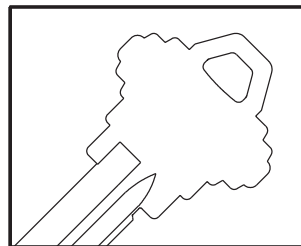

**Plain**  
35-130 (5 Pin)  
35-131 (6 Pin)

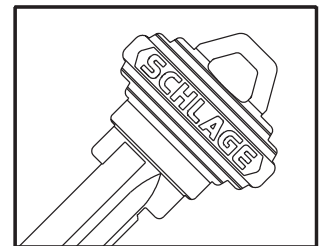

**Hotel Emergency Key**  
35-102 (6 Pin)

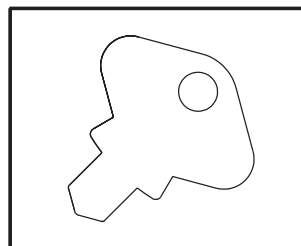

**Emergency Key**  
AL40 Function  
35-250

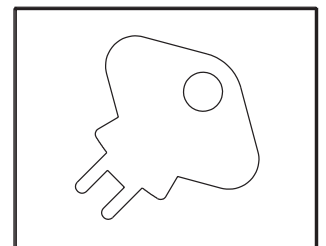

**Spanner Key**  
AL85 Function  
35-251

## PLUNGER ASSEMBLY INSTRUCTIONS

### Outside Plunger Assembly

Function AL40S

#### Disassemble Trim From Lock

1. Place a narrow tool into hole in inside lever to depress catch. Remove lever and driver. Repeat for outside lever and driver.

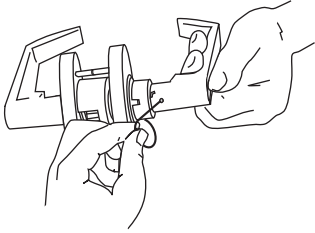

2. Rotate inside rose counterclockwise to remove from spring cage.

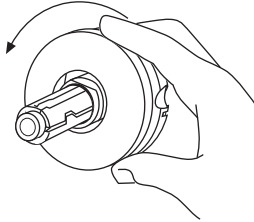

3. Using provided wrench, unscrew inside and outside castlenut bushings. Using Phillips screw driver, unscrew through bolts. Remove inside spring cage, anchor spring and outside rose and spring cage assembly.

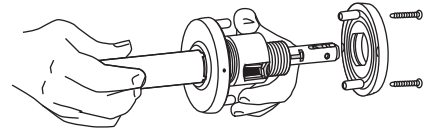

#### Disassemble Chassis

4. Remove chassis screws. Straighten lugs and remove housing from chassis. (If necessary, rap on edge of housing to loosen assembly.)

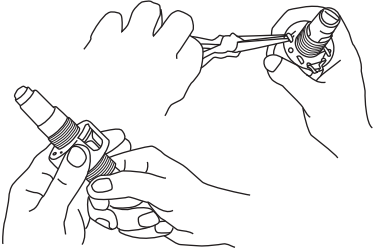

5. Depress slide, unhook and remove inside plunger and spindle.

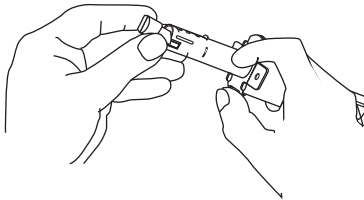

6. (Hold palms of hands around lock to prevent springs from escaping from slide.) Press forward with thumbs against frame tabs while pushing upward with index finger to disengage hub plate.

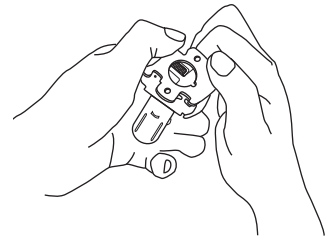

7. Remove slide and springs.

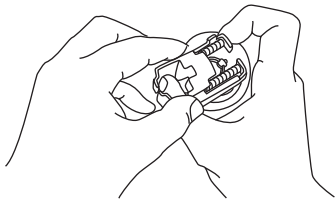

8. Remove cam from outside spindle.

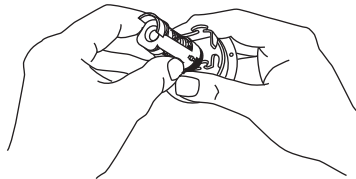

9. Use pliers to snap off outside button from plunger bar. Now remove the plunger bar.

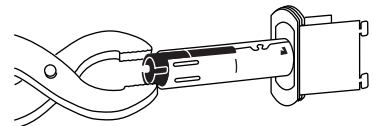



## Outside Plunger Assembly

Function AL40S

- 10.** To remove outside spindle, depress catch and push slide into hub and frame as far as it will go. Rotate spindle until catch aligns with slot in hub and plate. Depress catch again. Remove spindle.

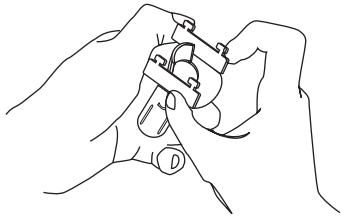

### Outside Button and Bar Assembly

- 11.** Insert outside spindle through lock frame from inside of frame. Insert plunger bar (less button assembly) into spindle as shown. The bar will stop against the catch in the spindle.

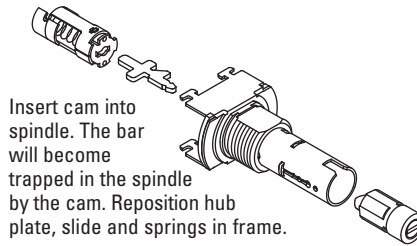

Insert cam into spindle. The bar will become trapped in the spindle by the cam. Reposition hub plate, slide and springs in frame.

- 12.** Install button assembly into spindle and snap firmly onto plunger bar. When properly assembled, rotating button will retract the slide.

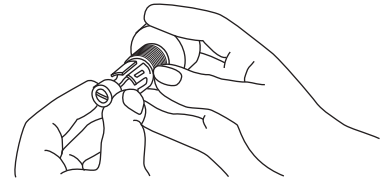

- 13.** Reverse steps to reassemble chassis and lock trim.

## Inside Plunger Assembly

Functions AL40S, AL50PD, AL53PD and AL85PD

Follow previous steps 1 thru 5 for disassembly of trim and chassis.

To remove outside lever of keyed functions, insert key into cylinder. Insert narrow tool into hole in lever. Turn key 90° and depress catch with tool. Pull off lever.

- 6.** Insert new plunger bar (less button assembly), depress slide and push plunger bar while releasing slide to hook into place.



- 7.** Install spindle over bar, rotate slightly and push into place. Slot on spindle should be on same side as slide jaws.

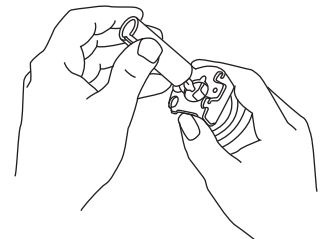

- 8.** Align plunger button assembly so lug fits into slot on spindle. Position plunger button assembly onto bar and snap firmly into place.

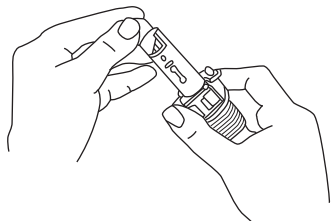

- 9.** Reverse steps to reassemble complete-lock and trim.

## INSTALLATION INSTRUCTIONS

**NOTE:** Accurate door preparation is essential for proper functioning of this lock. Follow template and instructions carefully.

### DOOR AND JAMB PREPARATION

**1**

#### Mark door

- Detach stub.
- Fold template at correct marking for door bevel (high or low bevel, or flat).
- Position template at correct height (suggested height for centerline is 38" (97mm) from floor). Mark center for lock hole. Also mark for (2) holes for mounting screws.
- Use stub to mark center of door thickness.

**HINT:** For retrofitting existing lock holes, fold template in half to locate position for the (2) mounting screws.

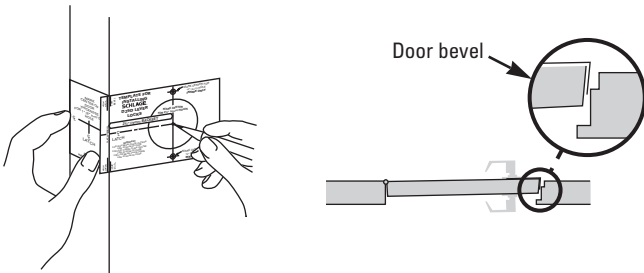

**2**

#### Drill (4) holes

- Drill a 2 1/8" (54mm) hole through door (from both sides to avoid damaging door).
- Drill (2) 5/16" (8mm) holes for mounting screws.
- Drill a 1" (25mm) or 7/8" (22mm) (depending on latch housing diameter) in door edge.

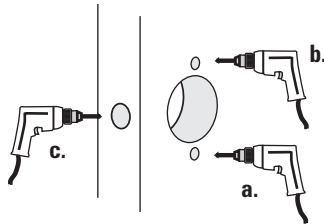

**3**

#### Install latch

- Insert latch into hole. Trace around faceplate.
- Chisel out wood until faceplate fits flat with door edge.
- Fasten latch to door so that beveled side of latchbolt faces jamb.

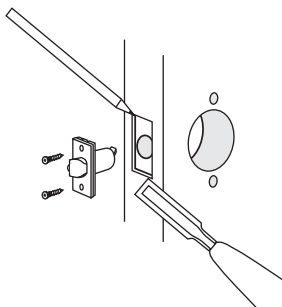

**4**

#### Install strike

- Mark vertical line and heightline on jamb exactly opposite center of latch hole.
- Drill (2) 1" (25mm) holes, 3/4" (19mm) deep, 5/16" (8mm) above and below heightline.
- Use strike plate to pattern for cutout. Clean out hole and install strike.

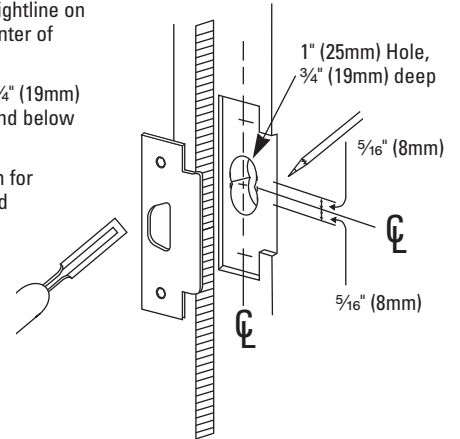

### LOCK INSTALLATION

**5**

#### Disassemble inside trim

- Insert pointed end of spanner wrench into hole in inside lever. Push to depress catch and remove lever. Also remove driver.
- Unscrew and remove castlenut bushing. (Use metal tool or plastic tool provided.)
- Remove spring cage.

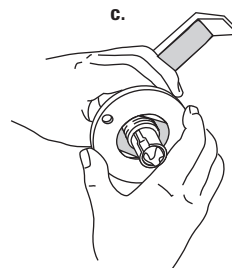
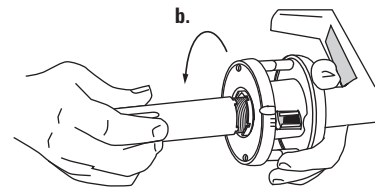
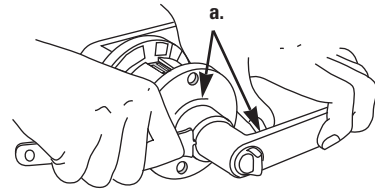

## INSTALLATION INSTRUCTIONS

**6**

### Install outside lock unit

**IMPORTANT:** This lock is factory preset for 1 $\frac{3}{4}$ " (44mm) doors. See other side to center chassis in door or to change adjustment for other door thicknesses.

Place outside lock unit into position. Make sure that latch prongs engage chassis housing, and latch retractor engages latch bar.

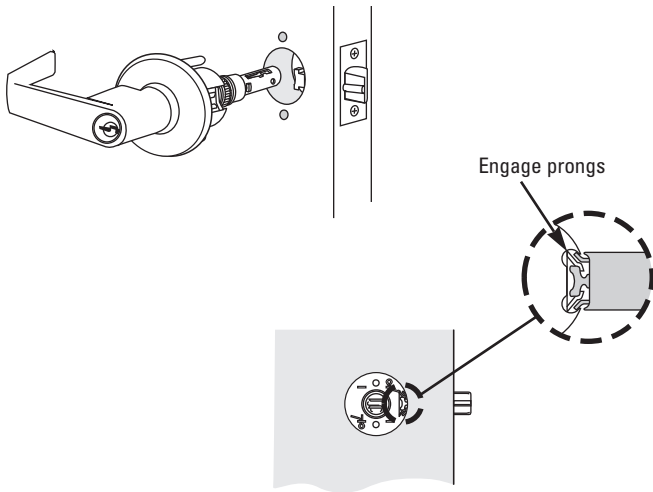

**7**

### Install inside assembly

- Hold outside unit in place.
- Put spring cage into position on chassis.
- Place castlenut bushing on threads of chassis. Hold outside lever in position while threading castlenut. You will hear a ratcheting sound. Continue tightening castlenut with tool until lock is fastened firmly.
- Insert and tighten mounting screws.
- Retighten castlenut with installation tool.

**CAUTION:** When using power screwdriver for installation, set to minimum torque setting

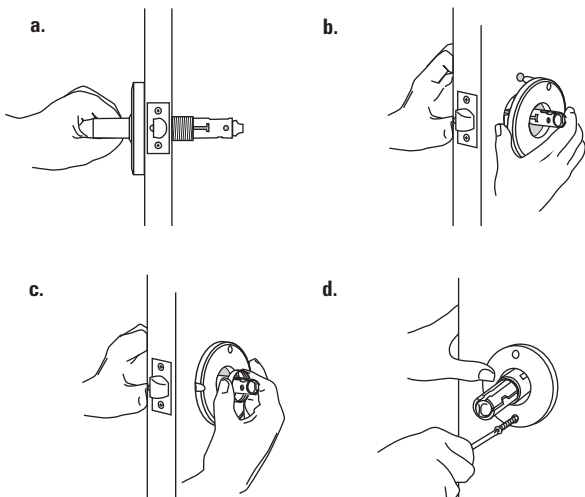

**8**

### Install inside rose

Align dimples on rose with grooves in spring cage. Place rose against door and rotate clockwise until dimples snap into slots next to the grooves.

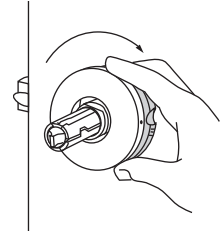

**9**

### Install lever, insert, and driver

- Remove driver from lever and install it onto spindle.
- Assemble plastic insert into lever. (**CAUTION:** Insert must be used for lock to function properly.)
- Slide lever and insert onto spindle. Push lever completely into place. (Pull on lever to make sure that catch is fully engaged.)

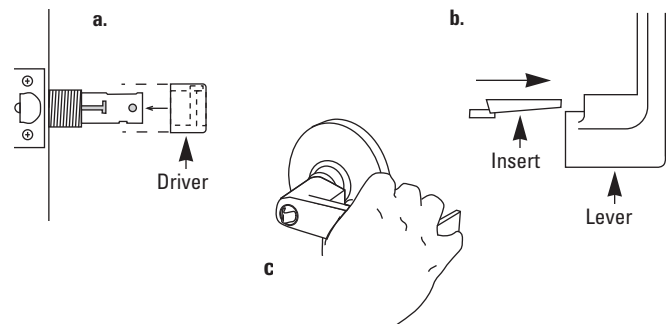

Test operation of lock to make sure you have followed instructions correctly.

## INTERCHANGEABLE CORE

### How to remove core

Insert control key and turn it clockwise 15 degrees until action stops. Pull on key to remove core.

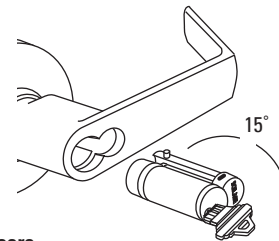

### How to replace core

Insert control key fully. Push core into lever as far as it will go. Turn key clockwise 15 degrees and push core completely into lever. Turn key back to normal position and remove from core.

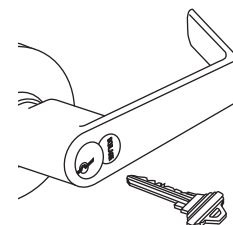

## INSTALLATION INSTRUCTIONS

### HOW TO ADJUST FOR NON STANDARD DOOR THICKNESS

#### Remove outside lever

a. Non-keyed locks (except A40S; See step 2.)  
Place pointed end of spanner wrench into hole in lever. Push in to depress catch and remove lever and driver.

b. Keyed Locks (Use screwdriver instead of key for A40S locks.)

**HINT:** It is easier to remove a keyed lever if the lock is positioned in the door cutout.

Insert key into cylinder. Insert pointed end of spanner wrench (or similar tool) into hole in lever. Turn key one-quarter turn and push wrench to depress catch.

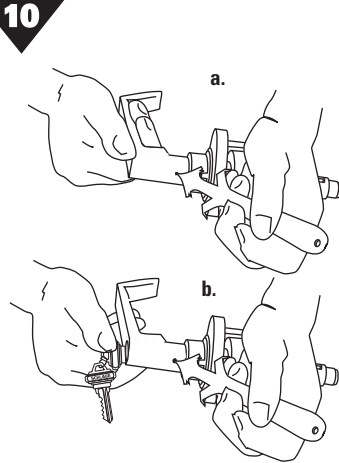

#### Adjust for door thickness

Use tool to rotate castlenut bushing until screw post lines up with correct door thickness mark.

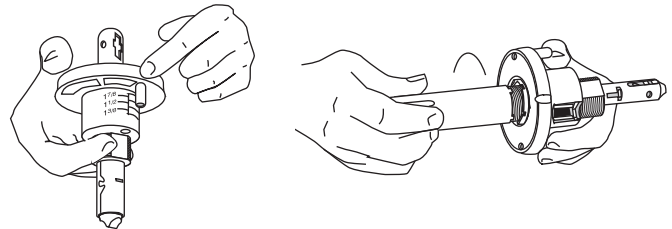

#### Reassemble outside lever

Reverse Step 10 to reassemble levers.

## INTERCHANGEABLE CORE RETROFIT KIT INSTRUCTIONS

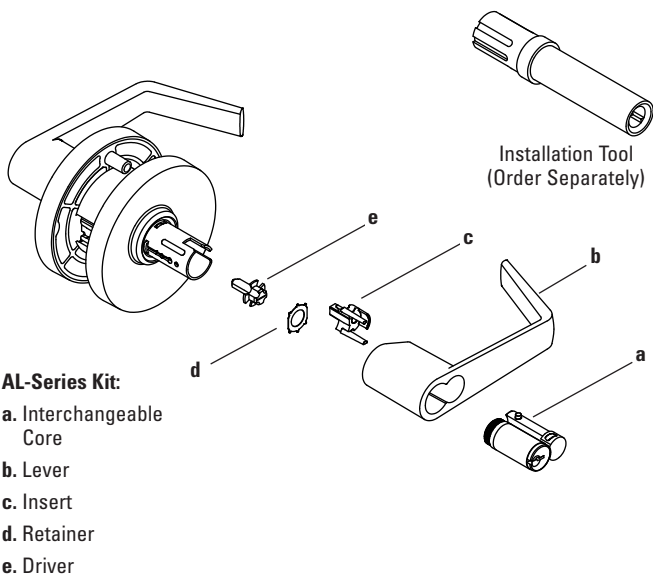

#### AL-Series Kit:

- a. Interchangeable Core
- b. Lever
- c. Insert
- d. Retainer
- e. Driver

#### Install Interchangeable Core Driver and Retainer

Place retainer and driver on end of installation tool as shown. Be sure the flat sides of the retainer are aligned as shown. Install the driver so the timing line is horizontal, or parallel with the latch. Insert installation tool into spindle and push in until it stops. Remove installation tool.

#### Install Interchangeable Core Lever

- a. Press insert into back of the lever as shown. Be sure the insert is firmly seated.
- b. Slide lever onto spindle up to catch. Insert smooth end of installation tool through core opening in lever and turn tool until it engages the driver. Turn installation tool clockwise and push lever on until it "clicks" into place. Pull on lever to be sure catch is engaged.

#### Remove Lever and Cylinder

To remove existing lever from lock assembly, insert pointed end of spanner wrench or small nail into hole in lever. Exert pressure on wrench while turning key slowly until catch depresses and pull off lever.

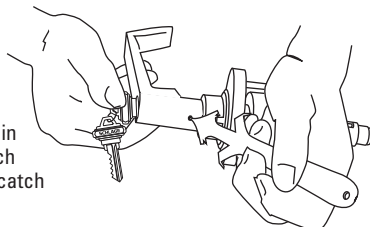

#### Install Interchangeable Core

With control key fully inserted, push core into lever housing, rotate key 15° clockwise and insert core completely. Remove control key.

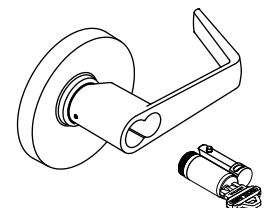

## DOOR HANDING

All Schlage locks are reversible. However, the correct hand should be specified for all pin tumbler locks so that they may be assembled to assure key cuts are in the upright position. Hand information is also necessary to ensure proper finish of latchbolt and strike for locks ordered that are to be installed on reverse bevel doors. Follow the diagram to correctly determine the hand of the door.

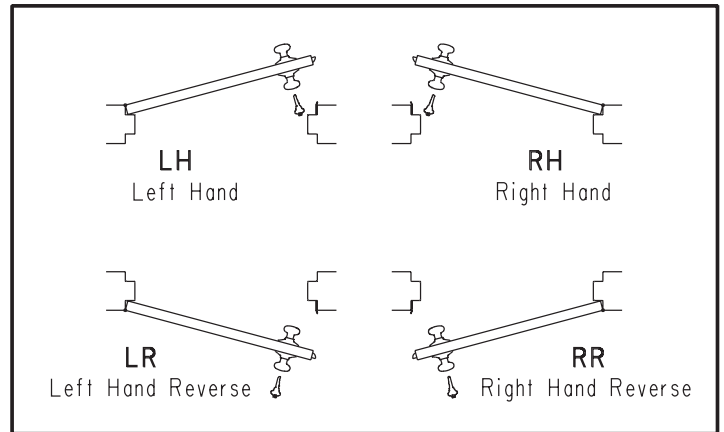

## ORDERING PROCEDURES

To order Schlage products, descriptive data should be in the same sequence as shown.

Line Item	Qty	Product	Outside		Inside		Hand	Latch	Strike	Dr Thk	Ext	Dim	Additional Details
			Des	Fin	Des	Fin							
1	2	3	4	5	6	7	8	9	10	11	12	13	14

- |   |   |  |
|---|---|--|
| <p>1. Line item number.</p> <p>2. Quantity.</p> <p>3. Complete lock product or part number.</p> <p>4. Outside design code.</p> <p>5. Outside finish code.</p> <p>6. Inside design code. Leave blank if same as outside design code.</p> <p>7. Inside finish code. Leave blank if same as outside finish code.</p> <p>8. Hand of door. Only one hand allowed per line item. Example: RH=Right Hand, LH=Left Hand, RR=Right Reverse, LR=Left Reverse.</p> <p>9. Latch. Leave blank for standard or specify part number if non-standard latch is required. LLL=Less latch.</p> | <p>10. Strike. Leave blank for standard or specify part number if non-standard strike is required. LLL=Less Strike.</p> <p>11. Door Thickness. Enter door thickness if non-standard. Example: 138= 1 3/8", 214= 2 1/4", 212= 2 1/2".</p> <p>12. Extension. Enter one of the following when doors 2" thick or greater are specified:<br/>         EE = Extended Equally,<br/>         EI = Extended Inside,<br/>         EO = Extended Outside,<br/>         ED = Extended Differently,<br/>         EI or EO assumes the latch will be centered on a 1 3/4" thick door, to which material has been added.</p> | <p>13. Enter dimension for non-standard strike lip length and mortise cylinder or blocking ring length.<br/>         Example:<br/>         012 = 1/8"      118 = 1 1/8"<br/>         018 = 3/16"    114 = 1 1/4"<br/>         025 = 1/4"      138 = 1 3/8"<br/>         031 = 5/16"    112 = 1 1/2"<br/>         037 = 3/8"      158 = 1 5/8"<br/>         050 = 1/2"      134 = 1 3/4"<br/>         078 = 7/8"      200 = 2"<br/>         100 = 1"        400 = 4"</p> <p>14. Enter detail for keying information and for special requirements.</p> |
|---|---|--|

## ORDERING EXAMPLES

Line Item	Qty	Product	Outside		Inside		Hand	Latch	Strike	Dr Thk	Ext	Dim	Additional Details
			Des	Fin	Des	Fin							
1	50	AL53PD	SAT	626				11-085	10-026				KEYED C000000
2	5	AL80RD	8SA	612	SAT					200	EE	138	KEYED E111111, KNURLED O/S LEVER
3	10	AL40S	JUP	609		625		11-068	10-001				W/41-005 EXT. LINK
4	12	AL53LD	NEP	605									LESS CYLINDER
5	12	20-720		606									

**NOTE:** Schlage order forms are available at no charge by contacting your Schlage Representative or Customer Service.

## LIMITED WARRANTY

Schlage Lock Company (the "Company") warrants to the original purchaser that the products manufactured by it (the "Product") to be free of defects in material and workmanship. Provided: (i) The Company has been notified within one year of purchase date and been given the opportunity of inspection by return of any alleged defective Product to the Company, or its authorized distributor, at the address specified herein, free and clear of all liens and encumbrances, transportation prepaid, accompanied by the statement of defects and proof of purchase; and (ii) The Product has not been modified, abused, misused, or improperly installed, maintained and/or repaired during such period; and (iii) Such defect has not been caused by corrosion or ordinary wear and tear.

THE COMPANY MAKES NO OTHER WARRANTY, AND ALL IMPLIED WARRANTIES INCLUDING ANY WARRANTY OF MERCHANTABILITY OR FITNESS FOR A PARTICULAR PURPOSE ARE LIMITED TO THE DURATION OF THE EXPRESSED WARRANTY PERIOD AS SET FORTH ABOVE.

THE COMPANY'S MAXIMUM LIABILITY HEREUNDER IS LIMITED TO THE PURCHASE PRICE OF THE PRODUCT. IN NO EVENT SHALL THE COMPANY BE LIABLE FOR ANY CONSEQUENTIAL, INDIRECT, INCIDENTAL OR SPECIAL DAMAGES OF ANY NATURE ARISING FROM THE SALE OR USE OF THIS PRODUCT, WHETHER IN CONTRACT, TORT, STRICT LIABILITY OR OTHERWISE.

### NOTE:

Should the Product be considered a consumer product as may be covered by the Magnusson Moss Federal Warranty Act, please be advised that: (1) Some states do not allow limitations on incidental consequential damages or how long an implied warranty lasts so that the above limitations may not fully apply; (2) This warranty gives specific legal rights and a buyer may also have other rights which may vary from state to state. For warranty service and shipping instructions, contact the Schlage Lock Company:

Customer Service Department  
2401 Bayshore Boulevard  
San Francisco, California 94134  
(800) 847-1864

The Schlage Lock Company reserves the right to make changes in designs and specifications or to make additions or improvements on its products without notice and without incurring any obligation to incorporate them on products previously manufactured. The Schlage Lock Company is not responsible for any modification, addition or alteration to our products by others.

NOTES



---

### **Administrative Offices**

1915 Jamboree Drive  
Colorado Springs, CO 80920  
(719) 264-5300  
FAX (719) 264-5382

### **Commercial Customer Service**

2000 Sierra Point Parkway  
Brisbane, CA 94005-1850  
(800) 847-1864  
FAX (800) 452-0663  
FAX (800) 616-6040  
Order Entry  
(800) 452-0665

### **Technical Services**

3899 Hancock Expressway  
Security, CO 80911  
(800) 847-1864  
FAX (719) 390-2682

### **International Division**

Ingersoll-Rand Architectural Hardware  
1076 Lakeshore Road East  
Mississauga, Ontario, L5E 1E4, Canada  
(905) 278-6128  
FAX (905) 278-1413

### **Internet**

<http://www.schlage.com>

