

**SCHLAGE®**

**A-Series Service Manual**

---

## INTRODUCTION

This manual contains a complete listing of parts and assemblies of A-Series locks manufactured by Schlage Lock Company, beginning in 1984. These locks are identified with the symbol MAB4 stamped on the lock housing. Exploded views of each lock function are provided with an accompanying dot chart to identify parts for replacement purposes.

In addition, this manual provides lock trim ordering procedures, cylinders, latches, strikes and all auxiliary components of A-Series MAB4 locks. Orders for finished components should always show finish designation. Orders for all Schlage® products must be placed through an authorized Schlage distributor or representative.

Schlage A-Series lock parts are manufactured to close tolerances and are interchangeable between functions using the same parts. Conversion of functions is accomplished by identifying the parts necessary for substitution and following the assembly procedures as illustrated on the lock drawings.

Some A-Series locks use threaded housings for designs furnished with threaded inside roses (Comet, Crown, Hanover, Magnolia, Meteor, and Planet). All other standard A-Series locks are furnished with non-threaded housings and snap-on inside roses.

For items not listed in this service manual, contact Schlage Lock Company for availability or allowable substitutions.

Schlage Lock Company reserves the right to make changes in designs and specifications or to make additions or improvements on its products without notice and without incurring any obligation to incorporate them on products previously manufactured. The Schlage Lock Company is not responsible for any modification, addition, or alteration to our product by others.

**Schlage Customer Service**  
2000 Sierra Point Parkway  
Brisbane, CA 94005-1850  
(800) 847-1864  
Fax (800) 452-0663  
<http://www.schlage.com>  
Printed in U.S.A.

## CERTIFICATIONS

ANSI/BHMA A156.2-1996,  
Series 4000, Grade 2.  
All functions U.L. listed for 3 hour doors.

## DOOR RANGE

1 3/8" to 1 7/8" Standard.  
2" to 2 1/2" Extended inside regular  
parts, assembled to order.

## METRIC CONVERSION CHART

All dimensions shown in this service manual are in inches. To convert to millimeters, use the metric conversion chart shown below.

Inch	MM
1/32	0.79
1/16	1.59
3/32	2.38
1/8	3.18
5/32	3.97
3/16	4.76
7/32	5.56
1/4	6.35
9/32	7.14
5/16	7.94
11/32	8.73
3/8	9.53
13/32	10.32
7/16	11.11
15/32	11.91
1/2	12.70
17/32	13.49
9/16	14.29
19/32	15.08

Inch	MM
5/8	15.88
21/32	16.67
11/16	17.46
23/32	18.26
3/4	19.05
25/32	19.84
13/16	20.64
27/32	21.43
7/8	22.23
29/32	23.02
15/16	23.81
31/32	24.61
1	25.40
2	50.8
3	76.2
4	101.6
5	127.0
6	152.4
7	177.8

INDEX

<i>Assemblies</i>	<i>Description</i>	<i>Page</i>
A10S	Passage Latch .....	2
A20S - Discontinued	Closet Latch .....	3
A25D	Exit Lock .....	4
A30D	Patio Lock .....	5
A40S	Bath/Bedroom Privacy Lock .....	6
A43D	Communicating Lock .....	7
A44S - Discontinued	Hospital Privacy Lock .....	8
A53PD	Entrance Lock .....	9
A55PD - Discontinued	Service Station Lock .....	10
A70PD	Classroom Lock .....	11
A73PD - Discontinued	Corridor Lock .....	12
A79PD	Communicating Lock .....	13
A80PD	Storeroom Lock .....	14
A85PD	Hotel/Motel Lock .....	15
A170	Dummy Trim .....	16
Parts Index	Dot Charts .....	17-19
Cylinder Units and Parts .....		20, 21
Interchangeable Cores, Designs and Parts .....		22, 23
Latch Units .....		24
Strikes .....		25
Designs .....		26
Finishes, Lubrication .....		27
Installation Tools, Backset Links, Door Reinforcements .....		28
Keys, Key Array Chart, Key Gage, Cylinder Loading Tool .....		29
Plunger Bar Assembly Instructions .....		30, 31
Installation Instructions .....		32-34
Interchangeable Core Retrofit Kit Instructions .....		35
Ordering Procedures .....		36
Limited Warranty .....		37

# A10S

## CHASSIS ASSEMBLY

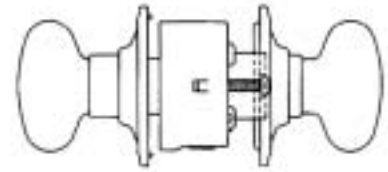

**PASSAGE LOCK**  
BOTH KNOBS ALWAYS UNLOCKED.

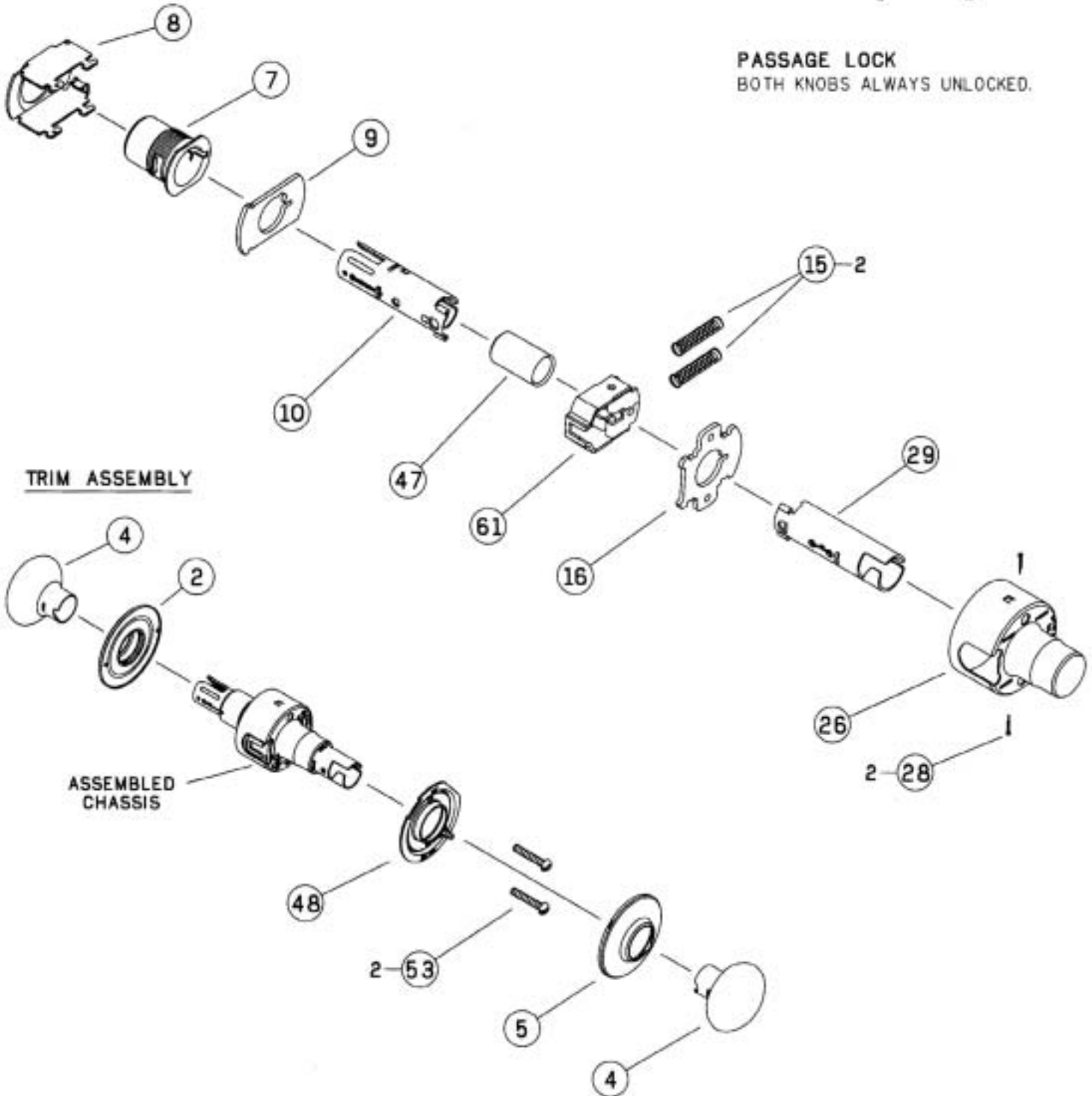

# A20S - DISCONTINUED

## CHASSIS ASSEMBLY

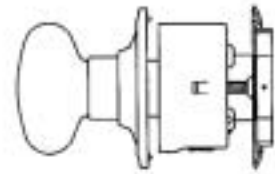

**CLOSET LATCH**  
 OUTSIDE KNOB AND INSIDE THUMBTURN  
 ARE ALWAYS UNLOCKED.

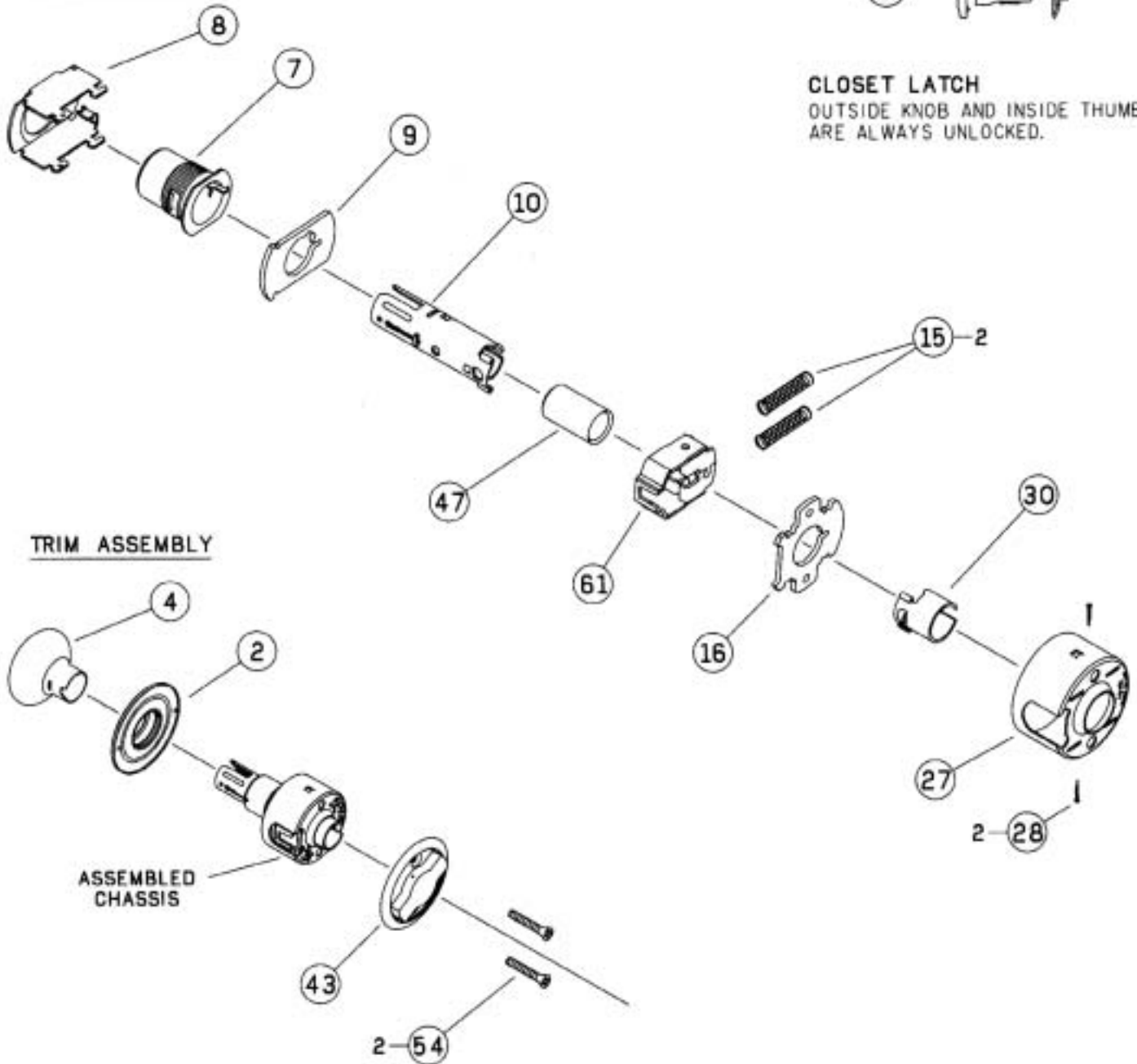

# A25D

CHASSIS ASSEMBLY

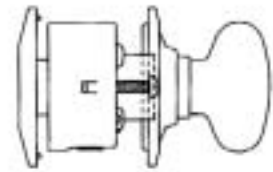

**EXIT LOCK**

BLANK PLATE OUTSIDE. INSIDE  
KNOB ALWAYS UNLOCKED. (SPECIFY  
DOOR THICKNESS, 1 3/8" OR 1 3/4").

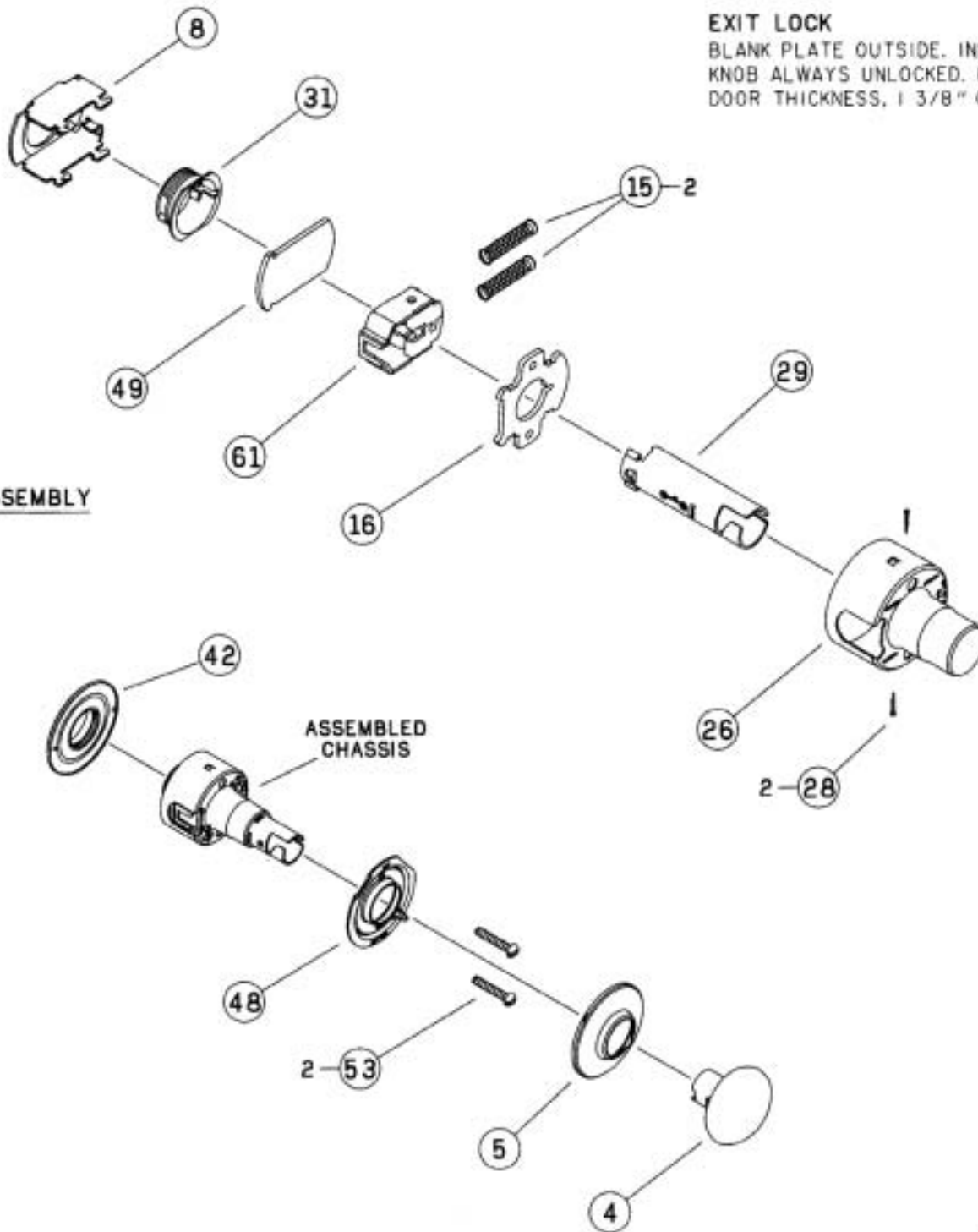

TRIM ASSEMBLY

# A30D

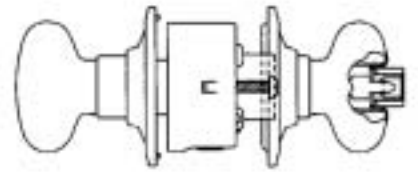

## CHASSIS ASSEMBLY

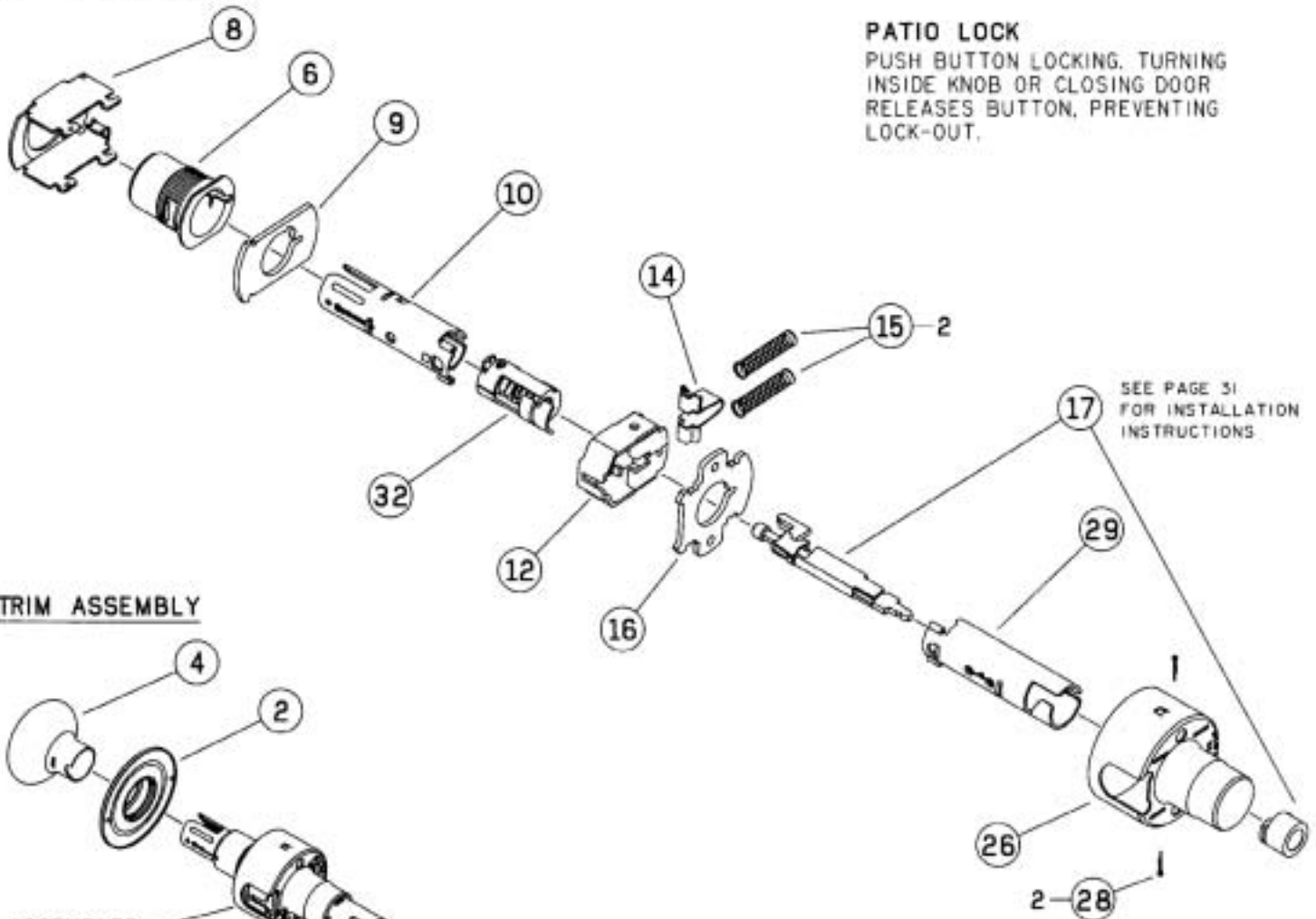

**PATIO LOCK**  
 PUSH BUTTON LOCKING. TURNING  
 INSIDE KNOB OR CLOSING DOOR  
 RELEASES BUTTON, PREVENTING  
 LOCK-OUT.

## TRIM ASSEMBLY

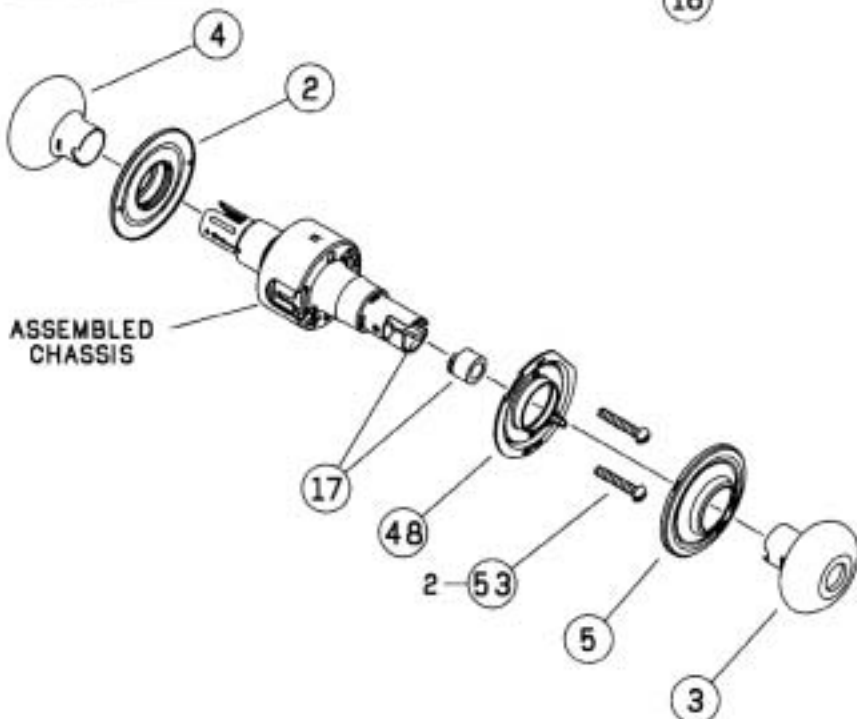

ASSEMBLED  
CHASSIS

## A40S

### CHASSIS ASSEMBLY

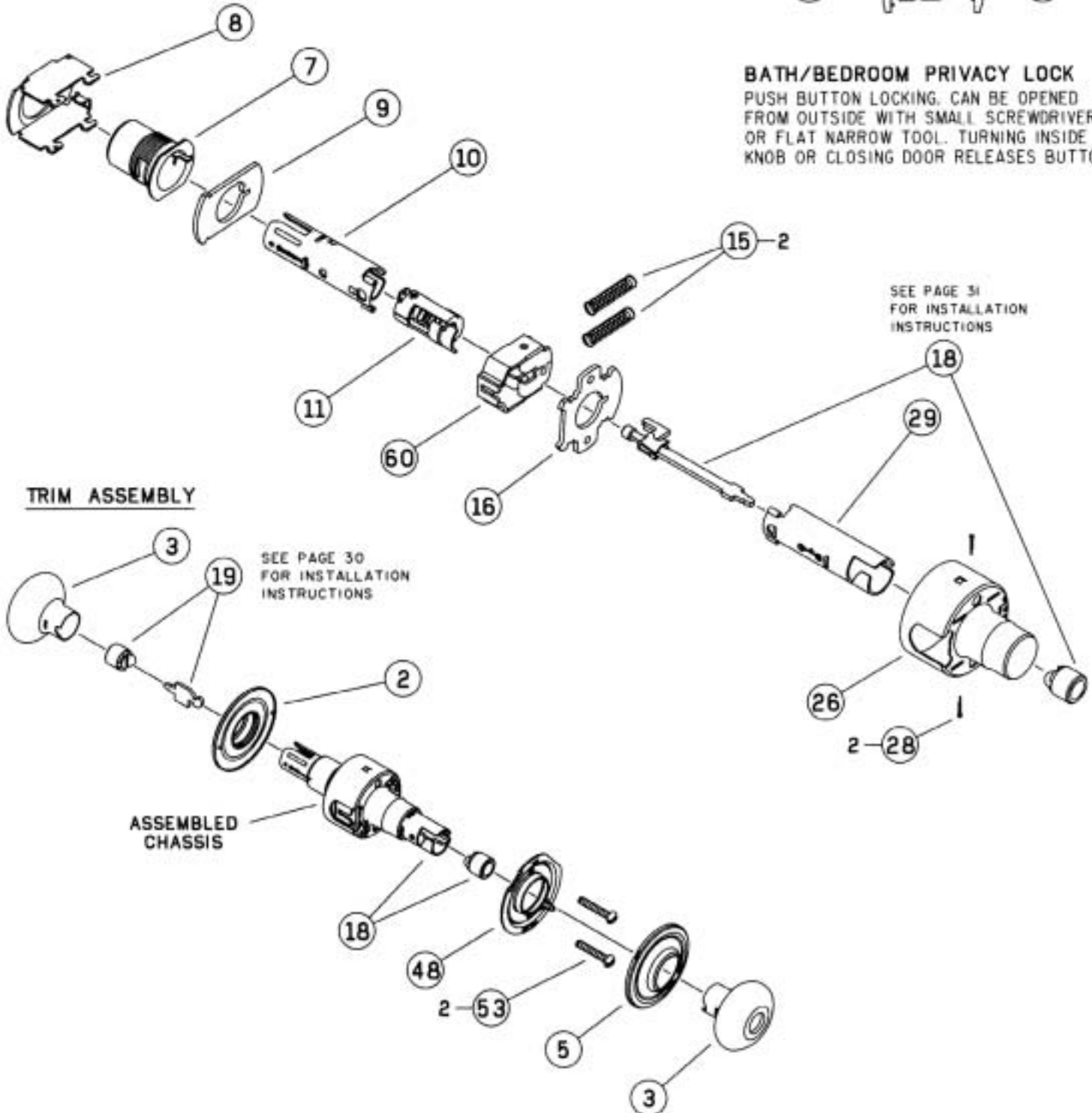



# A43D

## CHASSIS ASSEMBLY

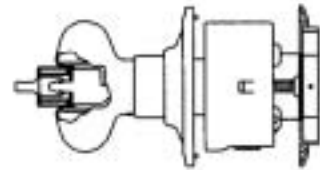

**COMMUNICATING LOCK**  
 TURN BUTTON IN OUTSIDE KNOB  
 LOCKS AND UNLOCKS BOTH KNOB  
 AND INSIDE THUMBTURN.

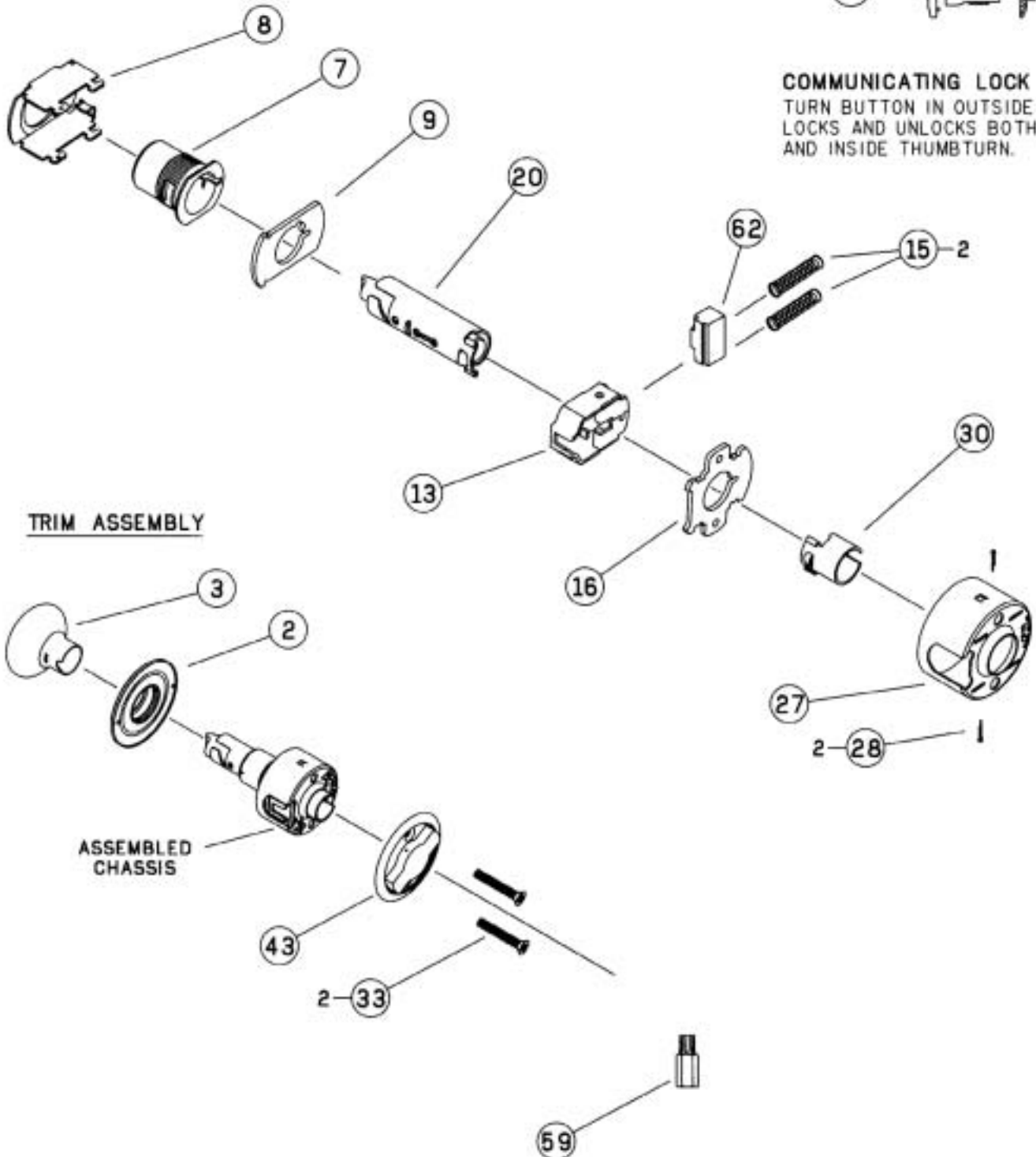

## A44S - DISCONTINUED

### CHASSIS ASSEMBLY

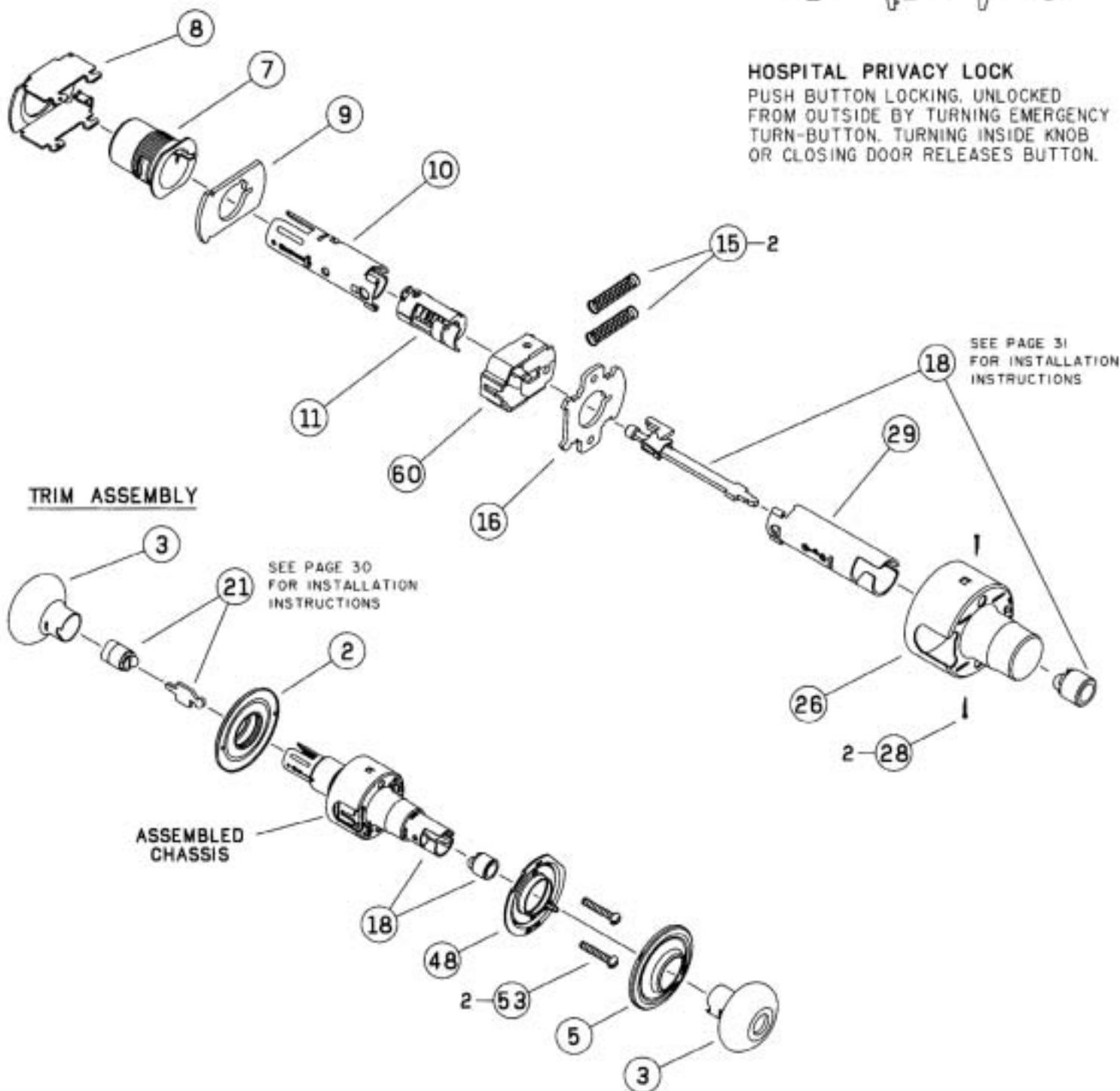

### HOSPITAL PRIVACY LOCK

PUSH BUTTON LOCKING. UNLOCKED FROM OUTSIDE BY TURNING EMERGENCY TURN-BUTTON. TURNING INSIDE KNOB OR CLOSING DOOR RELEASES BUTTON.

SEE PAGE 31 FOR INSTALLATION INSTRUCTIONS

SEE PAGE 30 FOR INSTALLATION INSTRUCTIONS

ASSEMBLED CHASSIS

# A53PD

## CHASSIS ASSEMBLY

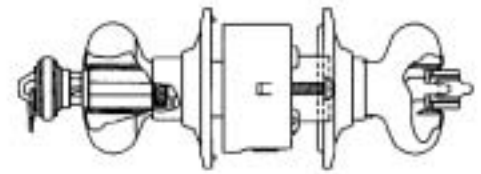

### ENTRANCE LOCK

**TURN/PUSH BUTTON LOCKING:**  
PUSHING AND TURNING BUTTON LOCKS  
OUTSIDE KNOB REQUIRING USE OF KEY  
UNTIL BUTTON IS MANUALLY UNLOCKED.  
**PUSH BUTTON LOCKING:**  
PUSHING BUTTON LOCKS OUTSIDE KNOB  
UNTIL UNLOCKED BY KEY OR BY TURNING  
INSIDE KNOB.

SEE PAGE 31  
FOR INSTALLATION  
INSTRUCTIONS

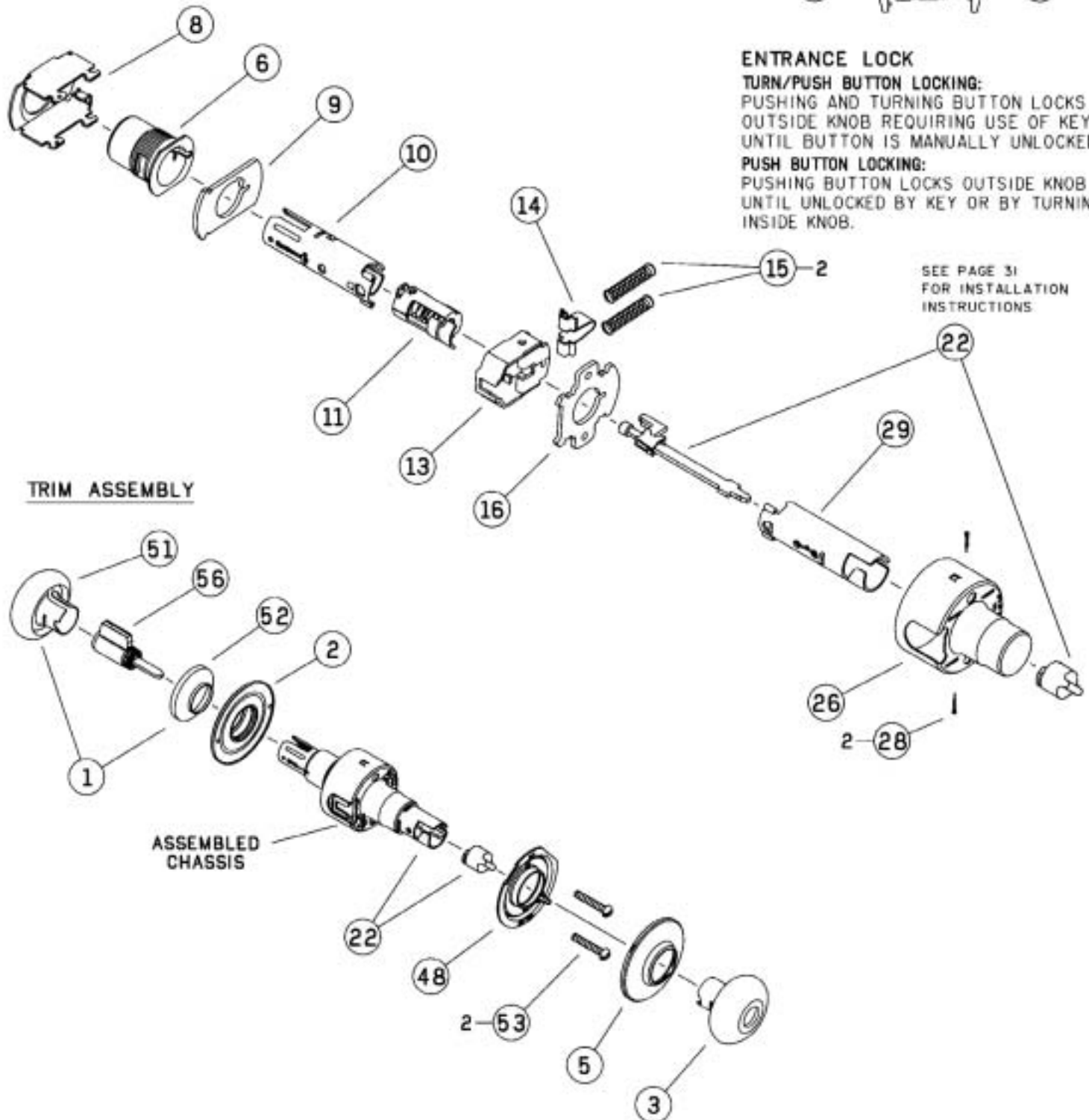

## TRIM ASSEMBLY

ASSEMBLED  
CHASSIS

## A55PD - DISCONTINUED

### CHASSIS ASSEMBLY

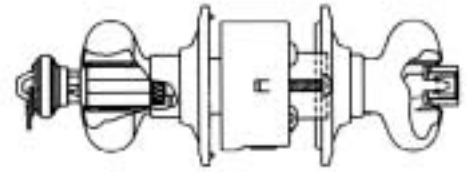
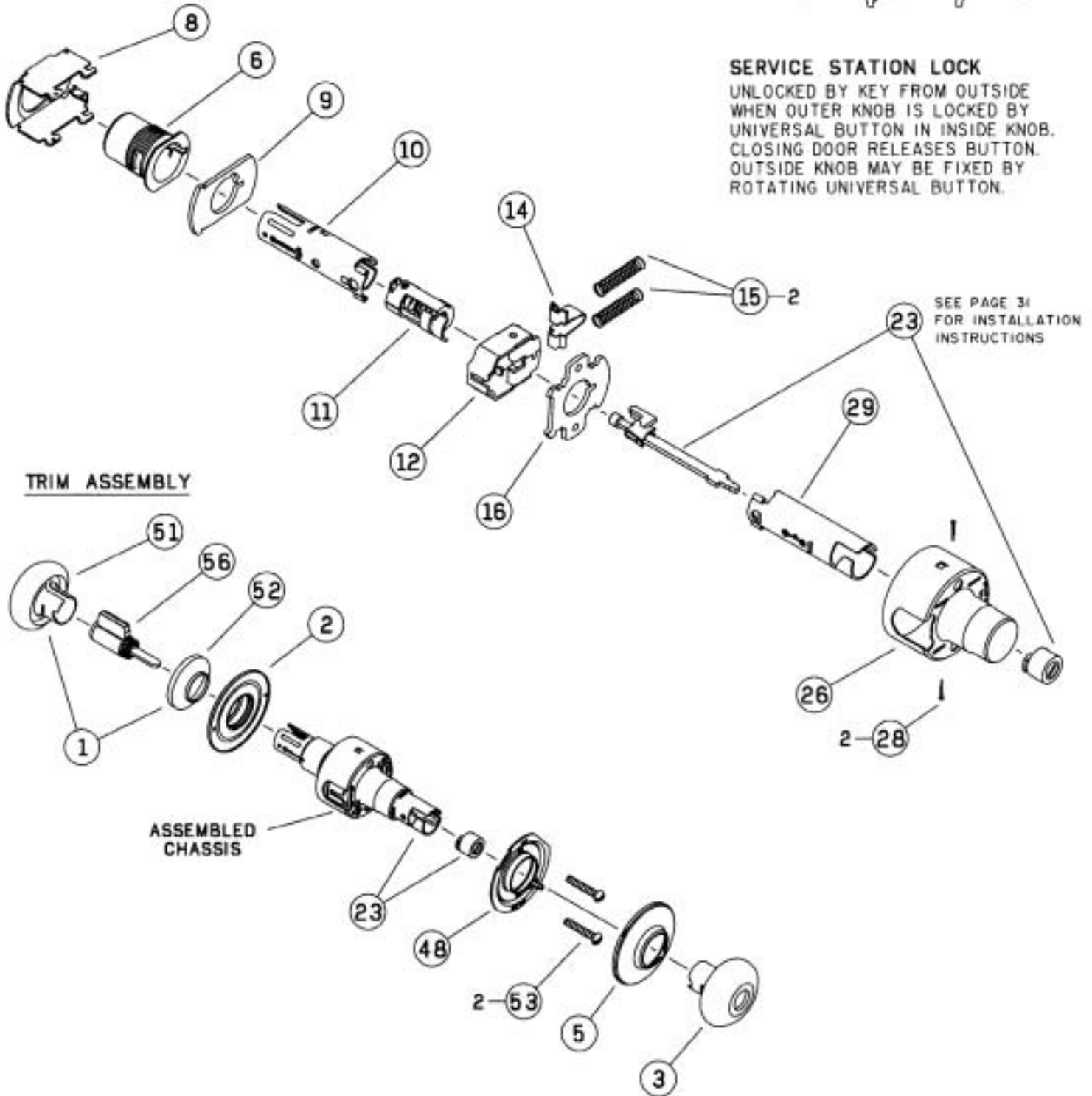

### SERVICE STATION LOCK

UNLOCKED BY KEY FROM OUTSIDE WHEN OUTER KNOB IS LOCKED BY UNIVERSAL BUTTON IN INSIDE KNOB. CLOSING DOOR RELEASES BUTTON. OUTSIDE KNOB MAY BE FIXED BY ROTATING UNIVERSAL BUTTON.

### TRIM ASSEMBLY

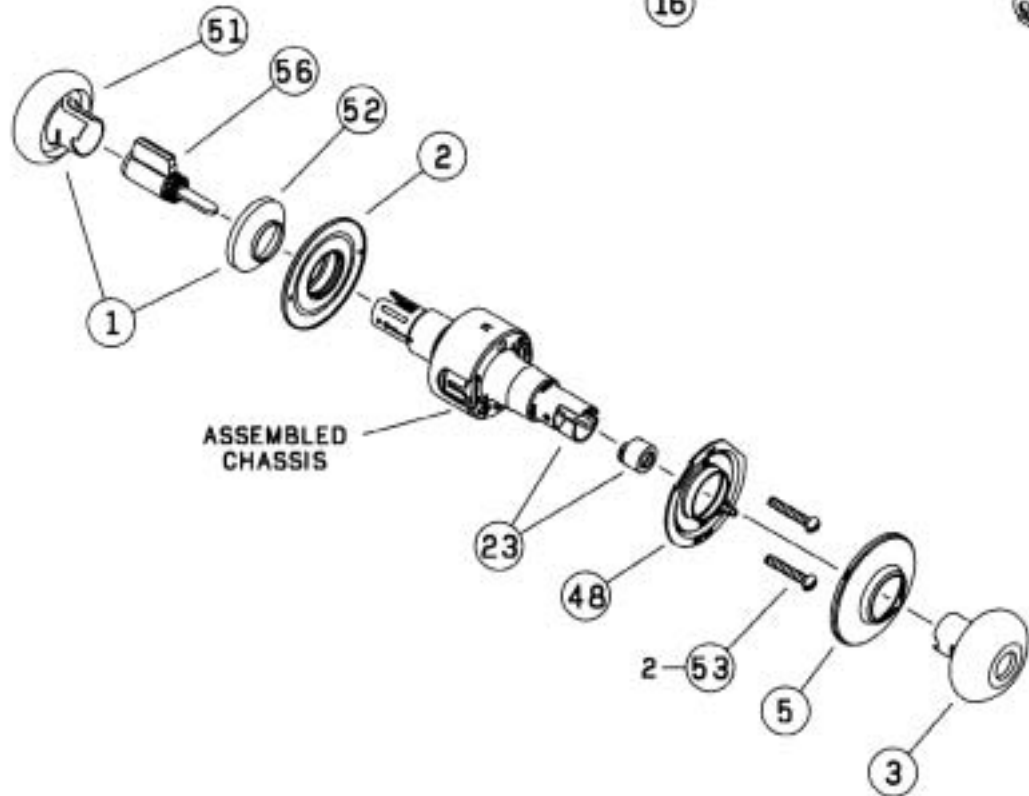

# A70PD

## CHASSIS ASSEMBLY

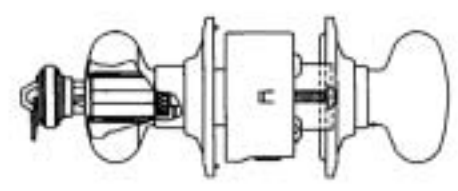

**CLASSROOM LOCK**  
OUTSIDE KNOB LOCKED AND UNLOCKED BY KEY. INSIDE KNOB ALWAYS UNLOCKED.

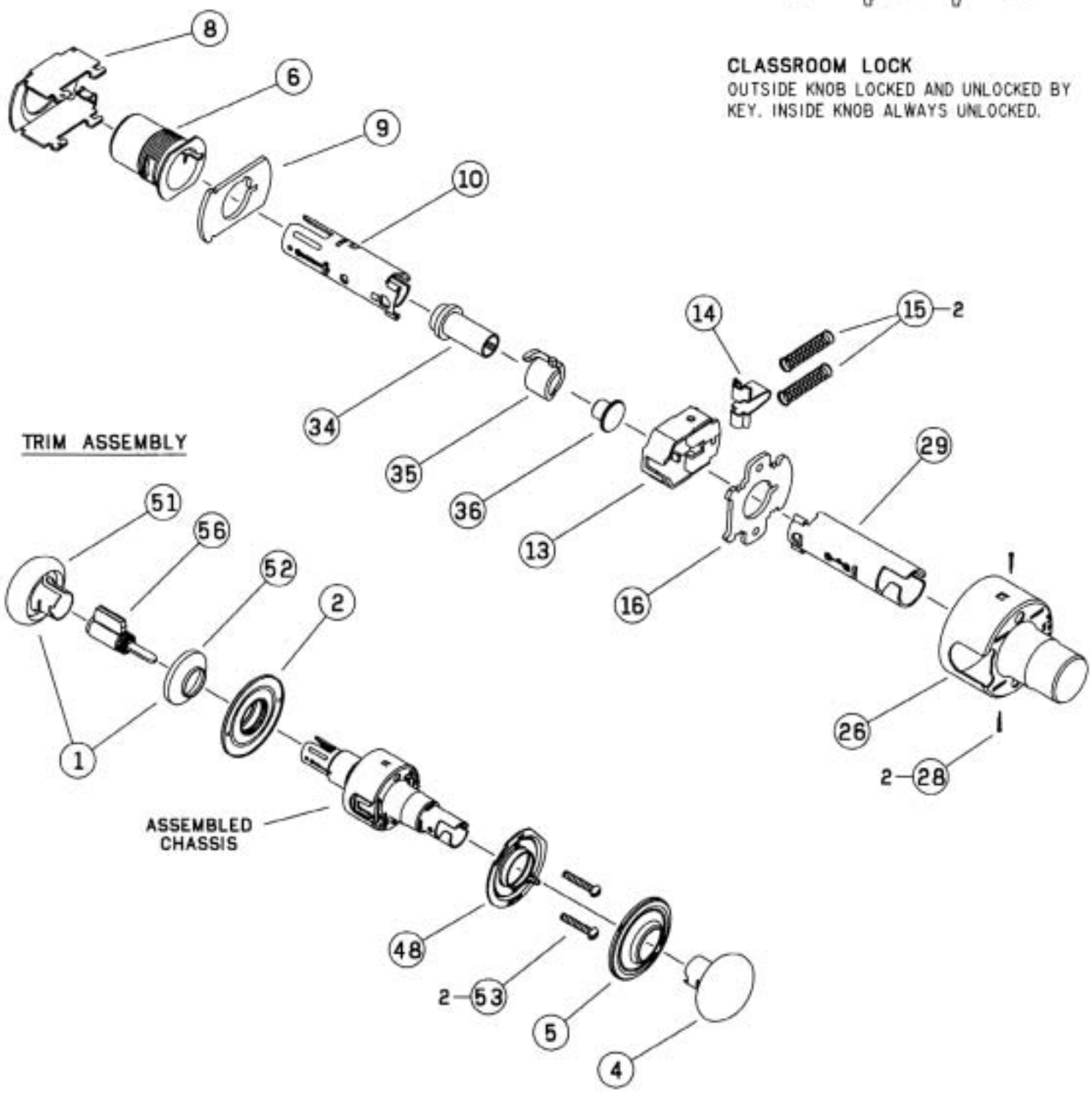

## TRIM ASSEMBLY

ASSEMBLED CHASSIS

# A73PD - DISCONTINUED

**CHASSIS ASSEMBLY**

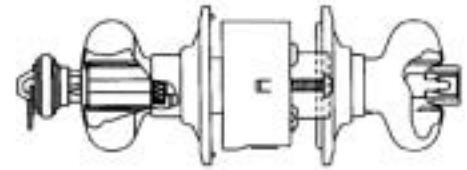
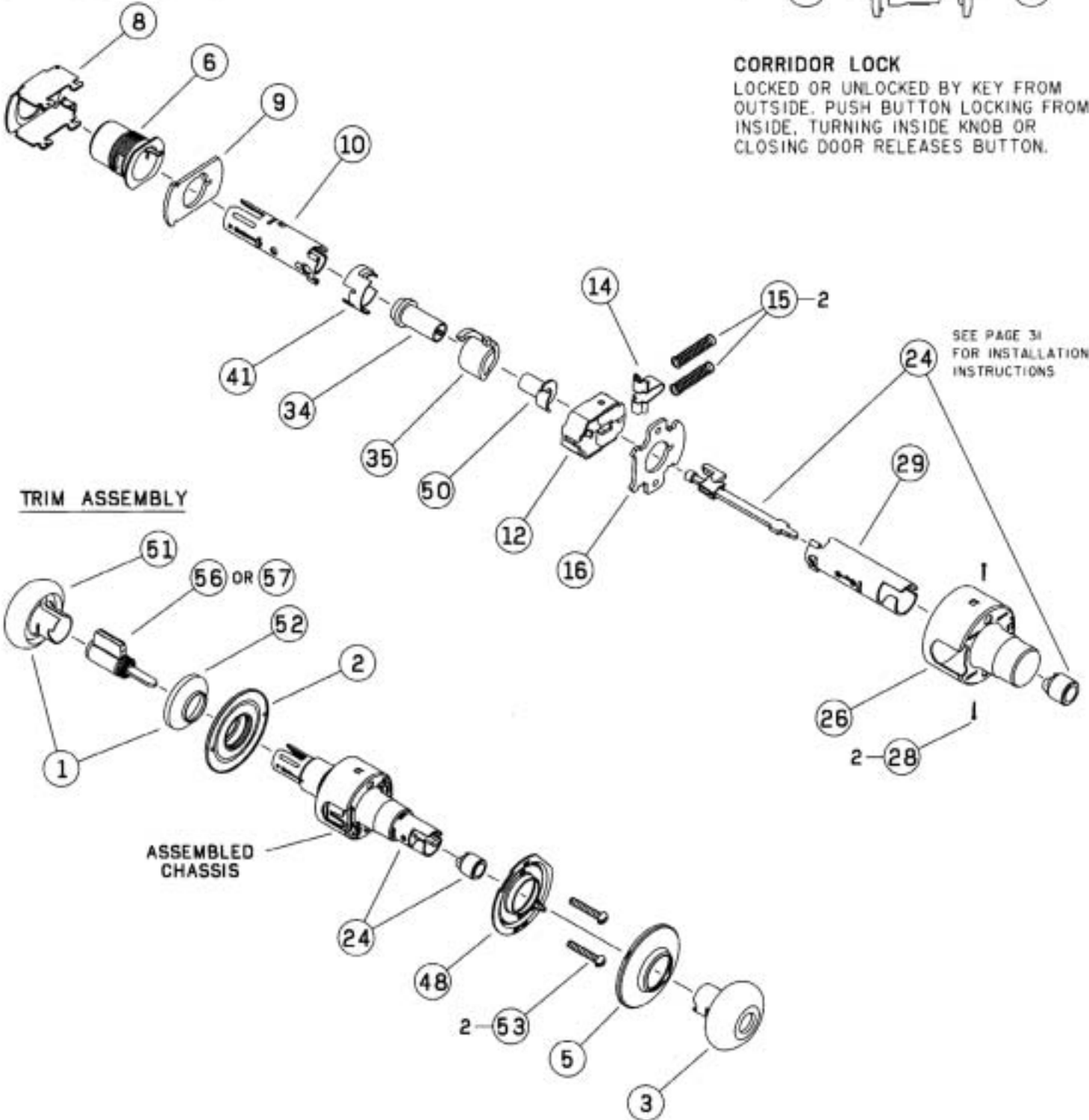

**CORRIDOR LOCK**

LOCKED OR UNLOCKED BY KEY FROM OUTSIDE. PUSH BUTTON LOCKING FROM INSIDE. TURNING INSIDE KNOB OR CLOSING DOOR RELEASES BUTTON.

# A79PD

## CHASSIS ASSEMBLY

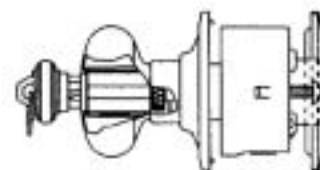

**COMMUNICATING LOCK**  
 LOCKED OR UNLOCKED BY KEY FROM  
 OUTSIDE. BLANK PLATE INSIDE.

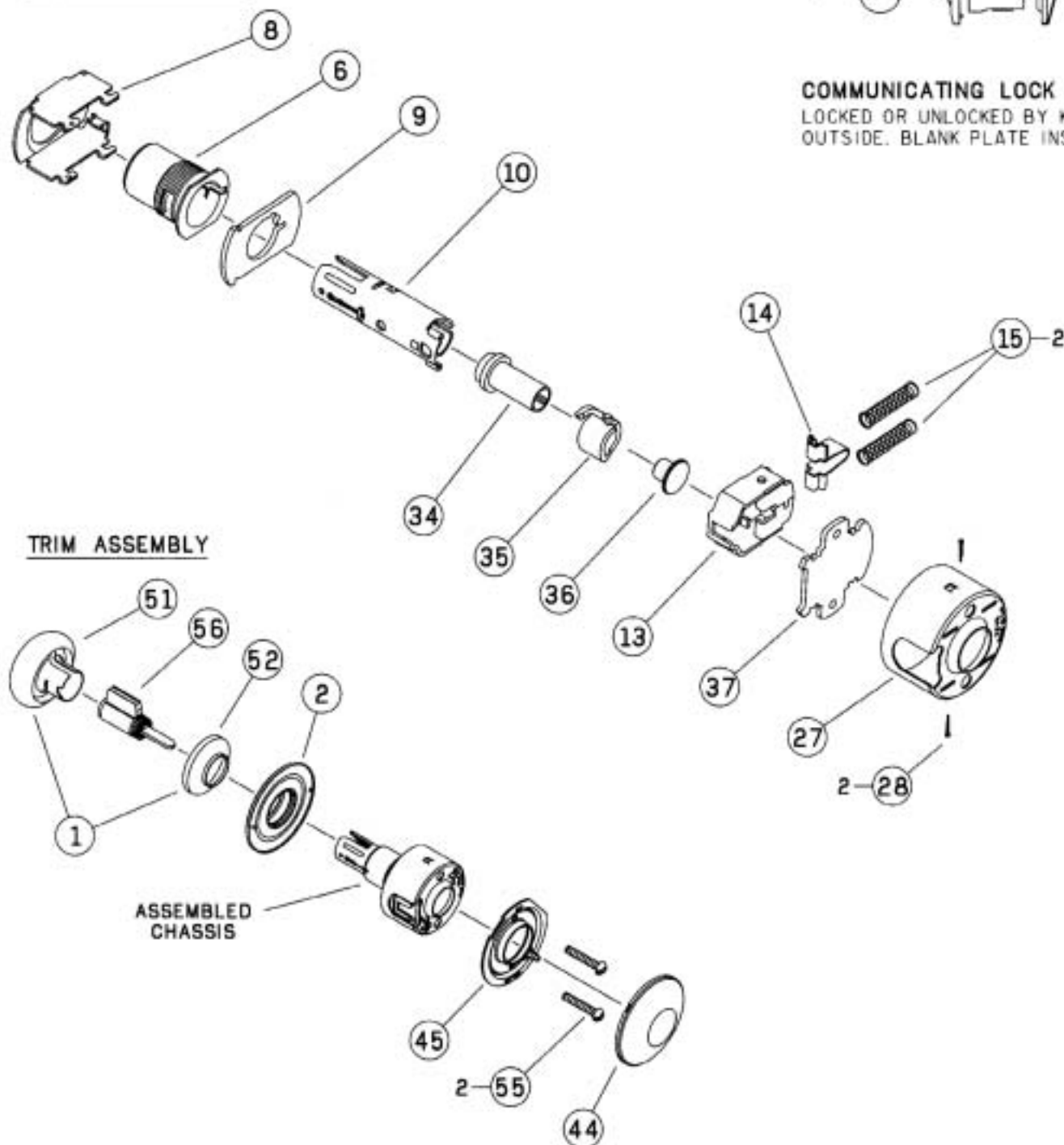

# A80PD

## CHASSIS ASSEMBLY

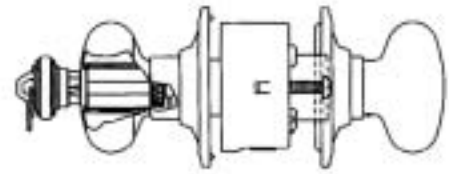
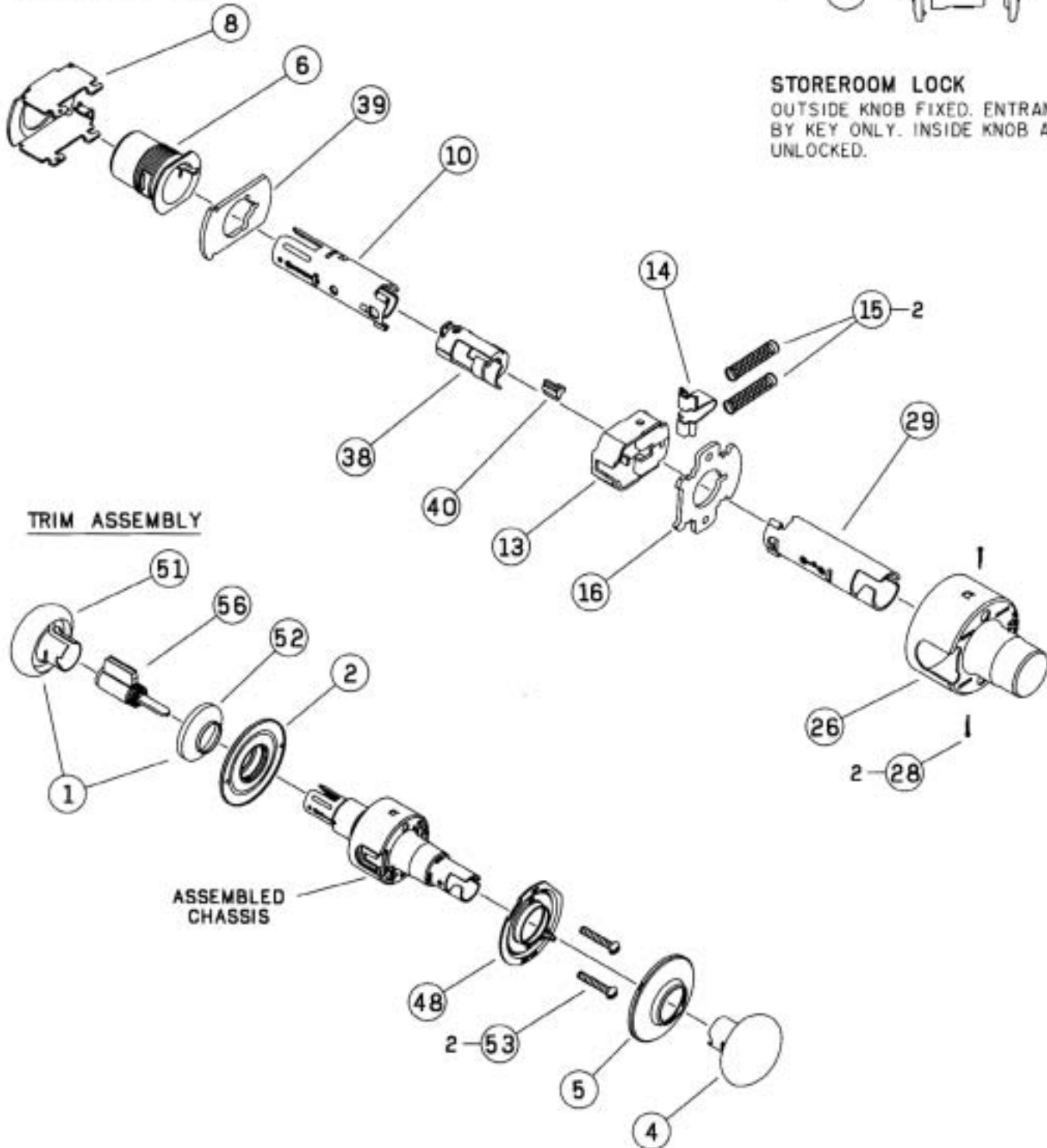

### STOREROOM LOCK

OUTSIDE KNOB FIXED. ENTRANCE  
BY KEY ONLY. INSIDE KNOB ALWAYS  
UNLOCKED.



# A85PD

## CHASSIS ASSEMBLY

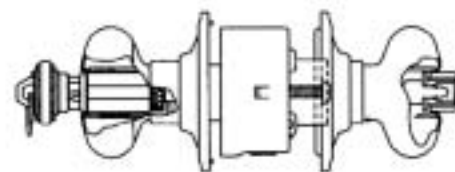

### HOTEL/MOTEL LOCK

OUTSIDE KNOB FIXED. ENTRANCE BY KEY ONLY. PUSH-BUTTON IN INSIDE KNOB ACTIVATES VISUAL OCCUPANCY INDICATOR, ALLOWING ONLY EMERGENCY MASTERKEY TO OPERATE. ROTATING INSIDE KNOB OR CLOSING DOOR RELEASES VISUAL OCCUPANCY INDICATOR. ROTATION OF INSIDE SPANNER-BUTTON PROVIDES LOCKOUT FEATURE BY KEEPING INDICATOR THROWN.

SEE PAGE 31 FOR INSTALLATION INSTRUCTIONS

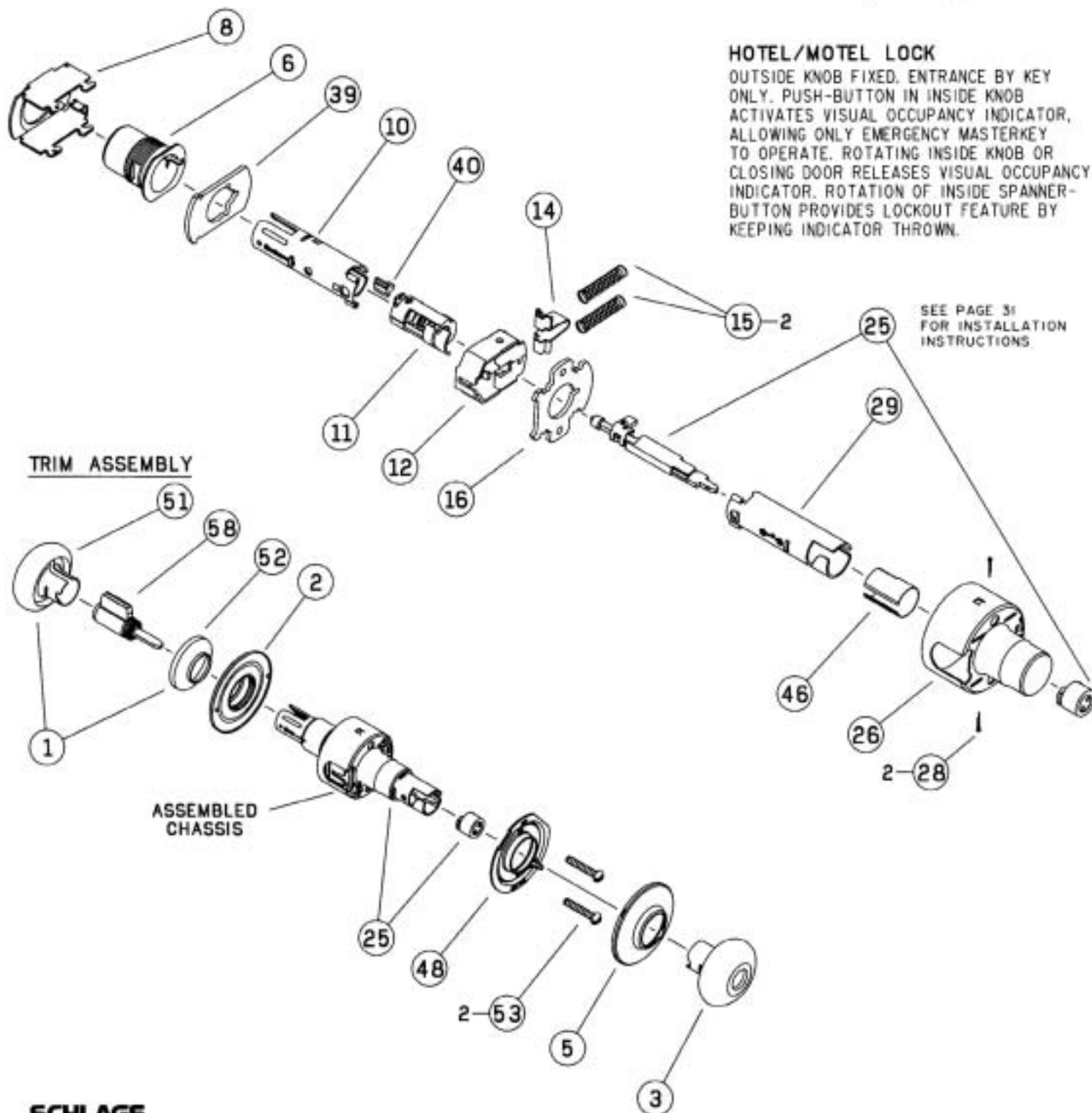

## TRIM ASSEMBLY

ASSEMBLED CHASSIS

## A170

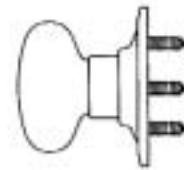

### DUMMY TRIM

SINGLE DUMMY TRIM FOR ONE SIDE OF DOOR. USED FOR DOOR PULL OR AS MATCHING INACTIVE TRIM.

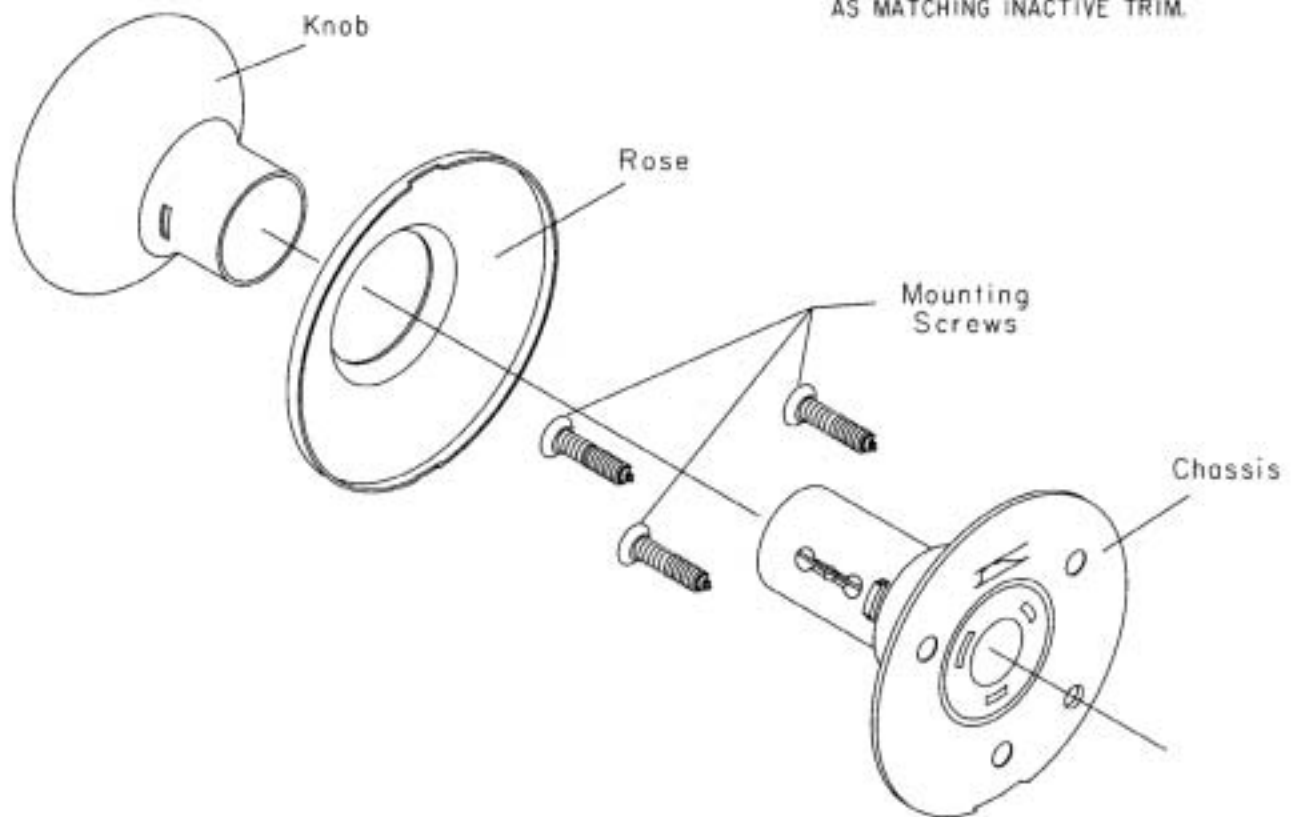

	Snap On Rose Designs. GEO. LEV. ORB. PLY. TUL.	Threaded Rose Designs. CRO.
Knob	01-008	
Rose	01-002	01-021
Chassis	A201-330	A201-684
Mtg. Screws. (3) Required.	C603-897	

SYMBOL NUMBER	DESCRIPTION	DISCONTINUED													
		A10S	A20S	A25D	A30D	A40S	A43D	A44S	A53PD	A55PD	A70PD	A73PD	A79PD	A80PD	A85PD
①	01-018**	●	●						●	●	●	●	●	●	●
②	01-001**	●	●		●	●	●	●	●	●	●	●	●	●	●
③	01-009**				●	2	●	2	●	●		●			●
④	01-008**	2	●	●	●					●				●	
⑤	01-002**	●		●	●	●		●	●	●	●	●		●	●
⑥	A20I-399*				●				●	●	●	●	●	●	●
⑦	A20I-406*	●	●			●	●	●							
⑧	A508-598	●	●	●	●	●	●	●	●	●	●	●	●	●	●
⑨	A508-399	●	●		●	●	●	●	●	●	●	●	●		
⑩	A30I-387	●	●		●	●		●	●	●	●	●	●	●	●
⑪	A30I-402				●		●	●	●						●
⑫	A590-158				●				●		●				●
⑬	A590-159						●		●		●		●	●	
⑭	A508-597				●				●	●	●	●	●	●	●
⑮	A508-605	2	2	2	2	2	2	2	2	2	2	2	2	2	2
⑯	A50I-305	●	●	●	●	●	●	●	●	●	●	●		●	●
⑰	01-055***				●										
⑱	01-056***					●		●							
⑲	01-057***					●									
⑳	01-058***						●								
㉑	01-059***							●							
㉒	01-060***								●						
㉓	01-061***									●					
㉔	01-062***										●				
㉕	01-063***														●
⑳	A30I-403*	●		●	●	●		●	●	●	●	●		●	●
	A30I-404*	●		●	●	●		●	●	●	●	●		●	●
	A30I-405*	●		●	●	●		●	●	●	●	●		●	●
	A30I-406*	●		●	●	●		●	●	●	●	●		●	●

- \* SPECIFY FINISH.
- \*\* SPECIFY DESIGN AND FINISH.
- \*\*\* SPECIFY FINISH AND DIMENSION. SEE PAGE 19 TO DETERMINE DIMENSION.

**Note:** Parts provided for doors 2" through 2 1/2" thick are for doors extended inside (EI) only.

SYMBOL NUMBER	DESCRIPTION	DISCONTINUED													
		A10S	A20S	A25D	A30D	A40S	A43D	A44S	A53PD	A55PD	A70PD	A73PD	A79PD	A80PD	A85PD
27	A508-600 HOUSING		●				●						●		
28	C503-008 COTTER PIN	2	2	2	2	2	2	2	2	2	2	2	2	2	2
29	A301-386 SPINDLE & CATCH, 1/5, 1 3/8" - 1 7/8" DRS.	●		●	●	●		●	●	●	●	●		●	●
	A301-409 SPINDLE & CATCH, 1/5, 2" - 2 1/4" DRS.	●		●	●	●		●	●	●	●			●	●
	A301-410 SPINDLE & CATCH, 1/5, 2 1/2" DRS.	●		●	●	●		●	●	●	●			●	●
30	A501-633 SPINDLE, 1/5, 1 3/8" - 1 7/8" DRS.		●				●								
	A500-001 SPINDLE, 1/5, 2" - 2 1/4" DRS.		●				●								
	A500-002 SPINDLE, 1/5, 2 1/2" DRS.		●				●								
31	A501-498 HUB, 1 3/8" - 1 1/2" DRS.			●											
	A501-499 HUB, 1 5/8" - 1 7/8" DRS.			●											
32	A301-391 CAM				●										
33	A508-649* SCREW, MTG, 1 3/8" - 1 7/8" DRS.						2								
	A508-650* SCREW, MTG, 2" - 2 1/2" DRS.						2								
34	A501-721 PLUG, CAM									●	●	●			
35	A501-776 SPIRAL CAM									●	●	●			
36	A501-791 SPACER, CAM									●		●			
37	A501-768 PLATE, INSIDE											●			
38	A201-370 CAM													●	
39	A501-901 PLATE, OUTSIDE													●	●
40	A501-615 WEDGE													●	●
41	A501-782 SLEEVE, CAM										●				
42	A201-558* ROSE, OUTSIDE			●											
43	A201-688* TURN & PLATE, INSIDE		●				●								
44	A501-766* ROSE, INSIDE												●		
45	A501-767 PLATE, MOUNTING												●		
46	A501-710 SLEEVE, SWIVEL														●
47	G570-232 PLUG, SPINDLE	●	●												
48	A201-377 MOUNTING PLATE, INSIDE	●		●	●	●		●	●	●	●	●		●	●
49	A501-874 PLATE, OUTSIDE			●											

\* SPECIFY FINISH.

**Note:** Parts provided for doors 2" through 2 1/2" thick are for doors extended inside (EI) only.

SYMBOL NUMBER	DESCRIPTION	DISCONTINUED													
		A10S	A20S	A25D	A30D	A40S	A43D	A44S	A53PD	A55PD	A70PD	A73PD	A79PD	A80PD	A85PD
50	A201-774 KEYWAY														
51	01-080** CYLINDER KNOB (LESS SLEEVE)														
52	01-081** SLEEVE, KNOB, CYLINDER														
53	A501-161 SCREW, MTG., 1 3/8" - 1 7/8" DOORS	2		2	2	2		2	2	2	2	2		2	2
	A501-818 SCREW, MTG., 2" - 2 1/2" DOORS	2		2	2	2		2	2	2	2	2		2	2
54	A501-634* SCREW, MTG., 1 3/8" - 1 7/8" DOORS		2												
	A501-635* SCREW, MTG., 2" - 2 1/2" DOORS		2												
55	A501-769 SCREW, MTG., 1 3/8" - 2" DOORS												2		
	A501-770 SCREW, MTG., 2" - 2 3/4" DOORS												2		
56	21-002* CYLINDER UNIT, 6 PIN														
	21-002-122* CYLINDER UNIT, 6 PIN, ORB DESIGN														
57	21-002-149* CYLINDER UNIT, 6 PIN, ORB DESIGN														
58	21-003* INDICATOR CYLINDER UNIT														
	21-003-168* INDICATOR CYLINDER UNIT, ORB DESIGN														
59	M504-426 TAMPER RESISTANT TORX TOOL BIT (ONE SUPPLIED PER CASE)														
60	A590-180 SLIDE, RESTORING														
61	A590-181 SLIDE, NON-RESTORING														
62	A508-641 STOP, SLIDE														

- \* SPECIFY FINISH.
- \*\* SPECIFY DESIGN AND FINISH.

### Plunger and Button Dimensions

Number	Design	Door Range	Dimension	Number	Design	Door Range	Dimension
01-055 (A30)	PLY	138-178	360	01-059 (A44 OUT)	PLY	138-212	106
		> 178-214	424				170
		> 214-212	449		01-062 (A73)	ORB	138-178
138-178	428	428					
01-056 (A40 and A44 INS)	ORB	> 178-214	492	01-063 (A85)	PLY	138-178	363
		> 214-212	517			> 178-214	427
01-057 (A40 OUT)	ORB	138-212	070			> 214-212	452
135		138-178	431				
01-058 (A43 OUT)	ORB	138-258	281		> 178-214	497	
		349	> 214-212	520			

**Notes:**

PLY Design = All knob or lever designs other than ORB.

ORB Design = ORB design only.  
> = Greater than.

Parts provided for doors 2" through 2 1/2" thick are for doors extended inside (E1) only.

## CYLINDER UNITS AND PARTS

Schlage locks are provided with cylinder units precision built to extremely close tolerances and the highest standards of accuracy. Phosphor bronze springs, nickel silver keys and pins are used throughout the Schlage offering. The best combination of materials is used to ensure the manufacture of cylinders with ease of operation and long wear. To order locks less cylinder units, change product suffix letter "P" to "L". Example: A53LD. Primus® cylinders are available when key control and physical security are important concerns.

### CYLINDER UNITS

Standard Cylinders	Primus Cylinders		Description	Design
	High Security	Controlled Access		
21-002	20-524	20-724	6 Pin unit	All except ORB, COM, PLA
21-002-122	20-524-122	20-724-122	6 Pin unit (except A73 & A85)	ORB, COM, PLA
21-002-149	20-524-149	20-724-149	6 Pin unit (A73)	ORB, COM, PLA
21-003	Not Available		6 Pin indicator unit (A85)	All except ORB, COM, PLA
21-003-168			6 Pin indicator unit (A85)	ORB, COM, PLA

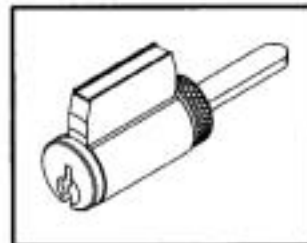

**21-002**  
Standard Cylinder

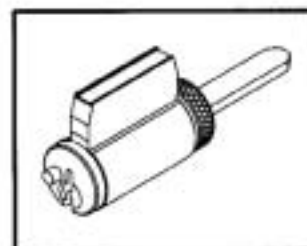

**21-003**  
Hotel Function Indicator Cylinder

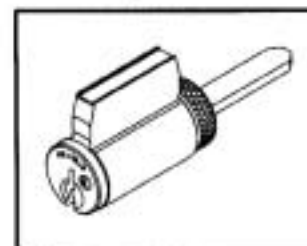

**20-524**  
Primus High Security  
U.L.437 Listed

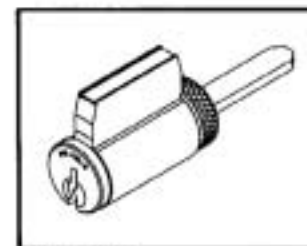

**20-724**  
Primus Controlled Access

### CYLINDER PARTS (Drawings are on page 21)

Symbol	Number	Description
A	33-006	Cylinder plug, 6 pin
B	33-216	Cylinder plug, indicator, 6 pin
C	34-101 thru 103	#1 thru #3 Top pin
D	34-202 thru 209	#2 thru #9 Master pin
E	34-300 thru 309	#0 thru #9 Bottom pin
F	A201-849	Body, 6 pin
G	A201-934	Bar & driver for 21-002-149
	A508-606	Bar & driver for 21-001 (Disc.) & 21-002
	A508-614	Bar & driver for 21-002-122
H	A501-693	Bar for 21-003-168
	A501-991	Bar for 21-003
I	A508-640	Spacer for ORB knob
J	C503-113	Tumbler spring
K	C503-115	Retainer cap spring
L	C503-116	Retainer cap pin
M	C503-118	Retainer cap
N	C503-767	Driver for 21-003
O	C603-195	Obstruction pin for 21-003
P	C604-144	Indicator pin spring for 21-003
Q	C604-371	Indicator pin for 21-003
R	XA10-594	5 Pin cylinder extension to fit 6 pin knobs (Requires A508-614 bar & driver)

#### Important:

Use only graphite or similar material for cylinder lubrication. Under no circumstance should any other type of material be introduced into the cylinder.

**STANDARD CYLINDER**

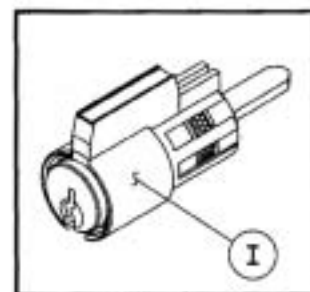
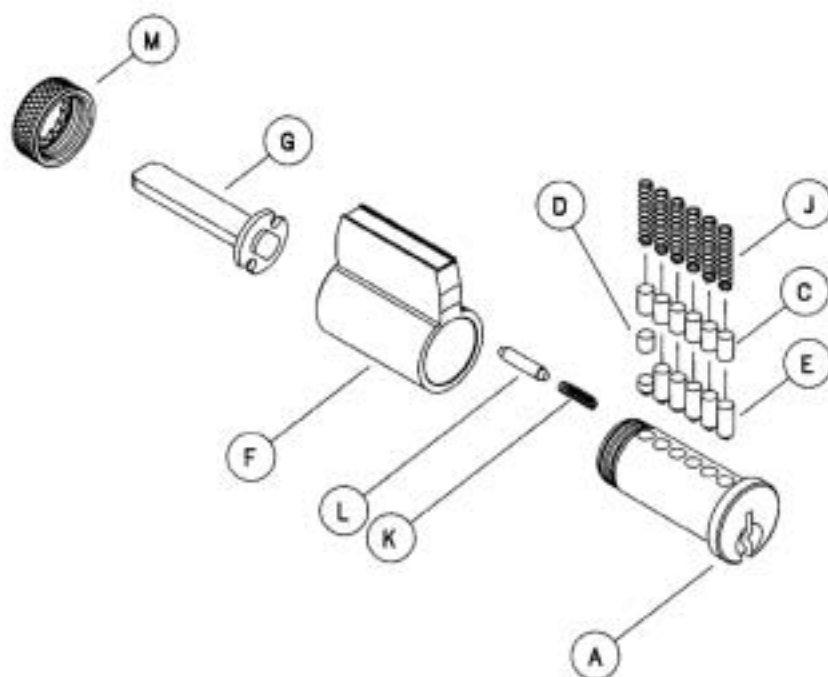

Standard Cylinder  
w/ORB Knob Spacer

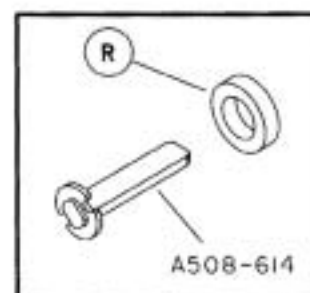

5 Pin Cylinder  
to 6 Pin Knob  
Conversion Parts

**HOTEL FUNCTION INDICATOR CYLINDER**

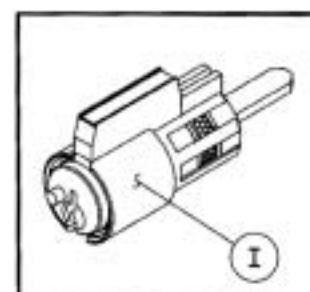
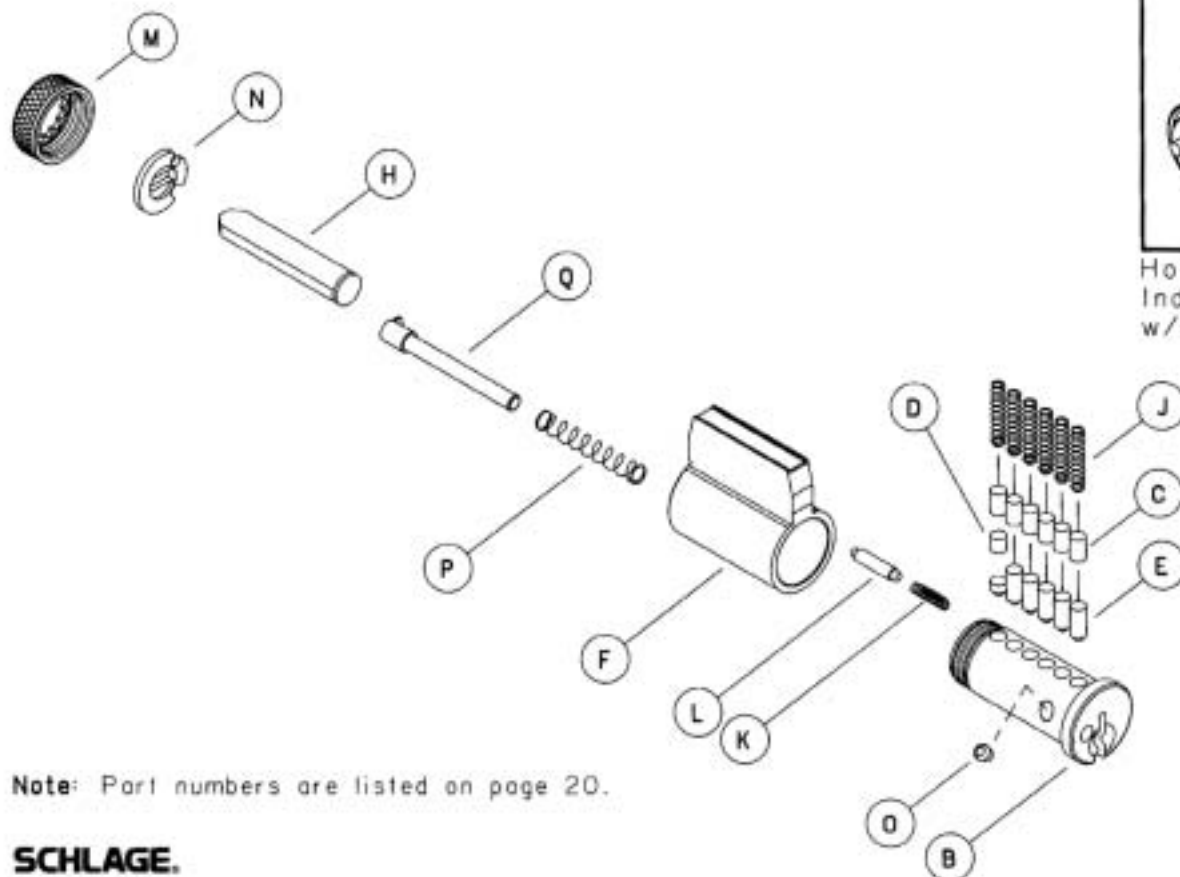

Hotel Function  
Indicator Cylinder  
w/ORB Knob Spacer

Note: Part numbers are listed on page 20.

## INTERCHANGEABLE CORES, DESIGNS AND PARTS

Available for all A-Series keyed functions, except Hotel/Motel function AB5, as complete locks or in retrofit kits. Existing installations can be retrofit without removing lock from door. To order locks with interchangeable cores, change product suffix letter "P" to "R". Example: A53RD. To order locks less interchangeable cores, change product suffix letter "P" to "J". Example: A53JD. Primus® cores are available when key control and physical security are important concerns.

### INTERCHANGEABLE CORES

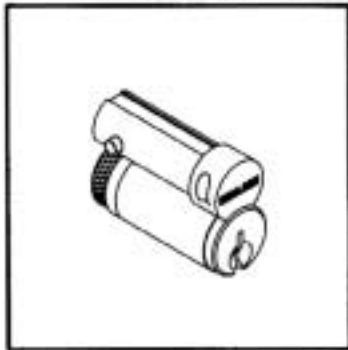

**23-030**  
Interchangeable Core w/logo

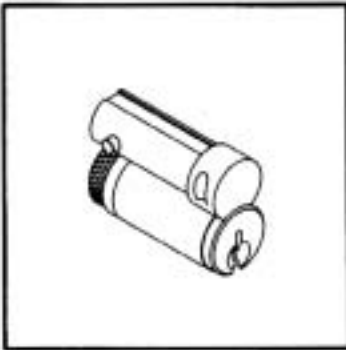

**23-031**  
Interchangeable Core w/o logo

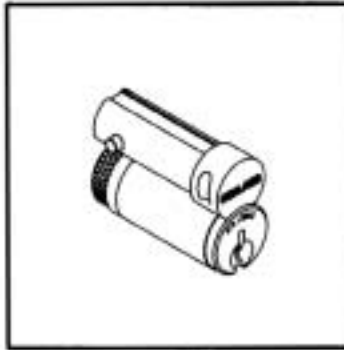

**20-740**  
Primus Interchangeable Core, w/logo, Controlled Access

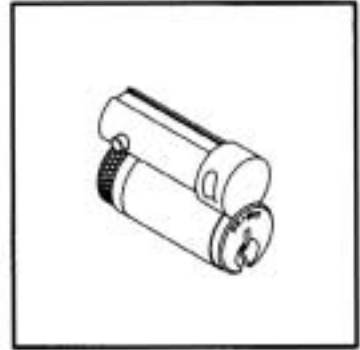

**20-741**  
Primus Interchangeable Core, w/o logo, Controlled Access

### INTERCHANGEABLE CORE DESIGNS

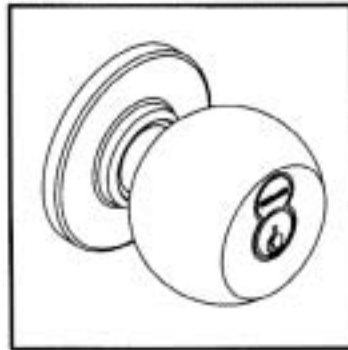

**Orbit**



**Plymouth**  
(Uses Orbit knob)



**Tulip**

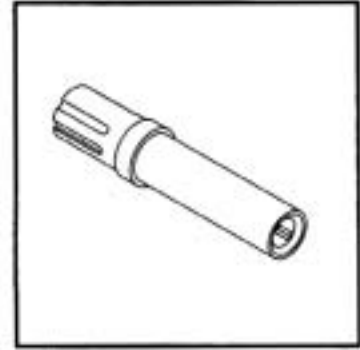

**M504-142 Installation Tool**  
Order as needed per project.

### INTERCHANGEABLE CORE ACCESSORY AND SERVICE PARTS

Number	Description
01-025	Knob, driver and retainer
01-026	Knob only
01-053	Driver and retainer
01-054	Knob, core, driver and retainer
20-740	Primus interchangeable core w/logo
20-741	Primus interchangeable core w/o logo
23-030	Interchangeable core w/logo
23-031	Interchangeable core w/o logo
A501-941	Retainer
C604-307	Driver
M504-142	Installation tool

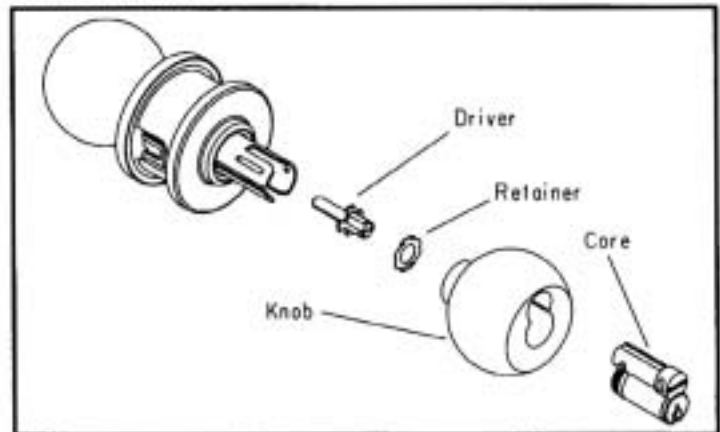

**01-054 Retrofit Kit**  
(See page 35 for retrofit kit instructions)



**INTERCHANGEABLE CORE**

To remove interchangeable core, insert control key and turn 15° to the right until action stops. Pulling on key will extract core from the knob. To install a new core, insert control key and push core into housing, rotate key 15° to the right and insert core completely. Rotate key back to original position and remove control key.

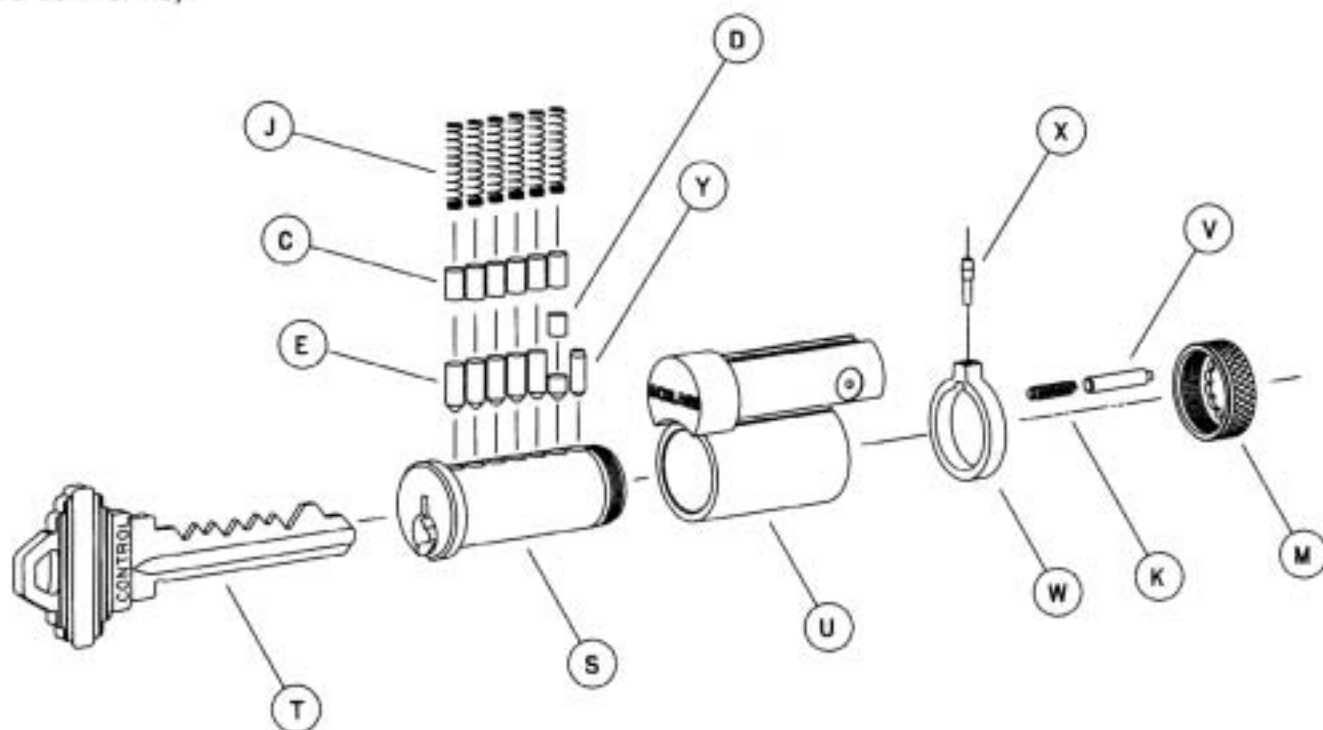
**INTERCHANGEABLE CORE PARTS**

Symbol	Number	Description
C	34-101 thru 103	#1 thru #3 Top pin
D	34-202 thru 209	#2 thru #9 Master pin
E	34-300 thru 309	#0 thru #9 Bottom pin
J	C503-113	Tumbler spring
K	C503-115	Retainer cap spring
M	C503-118	Retainer cap
S *	33-058	Plug, interchangeable core
T	35-056	Control key, blank
	48-056	Control key, cut
U *	B220-282	Interchangeable core body, w/logo
	B220-283	Interchangeable core body, w/o logo
V	C603-347	Retainer cap pin
W *	C603-956	Actuating ring
X *	C603-964	Actuating pin
Y *	C603-967	Control pin

\* Parts not compatible with cores manufactured before 1991.

**Important:**

Use only graphite or similar material for cylinder lubrication. Under no circumstance should any other type of material be introduced into the cylinder.

## LATCHES

All A-Series latches have adjustable faceplates for flat or beveled doors, except circular drive-in latches.

### Square Corner Latches

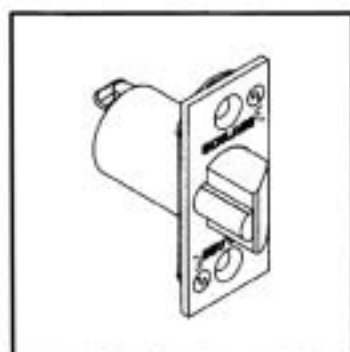

Deadlatch

### Round Corner Latches

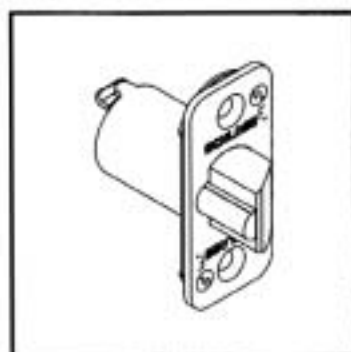

Deadlatch

### Drive-in Latches

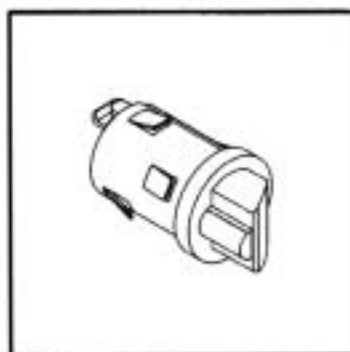

Deadlatch

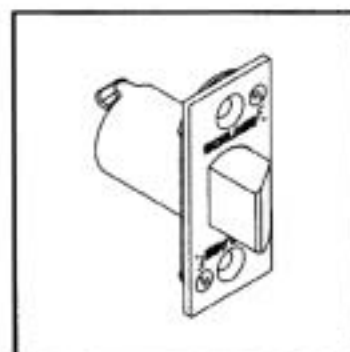

Springlatch

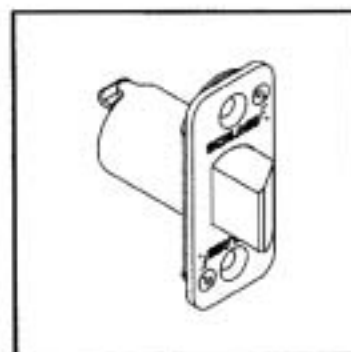

Springlatch

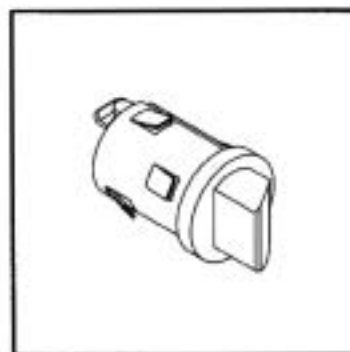

Springlatch

This kit adapts square corner latches and IO-001 strikes for 1/2" rabbeted door and frame preparations. Latches and strikes not included.

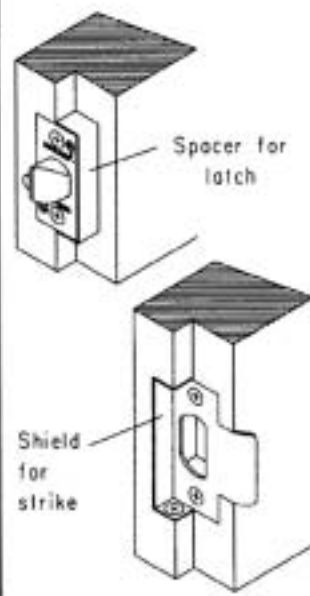

**39-030**  
Rabbeted Latch and Strike Kit

## LATCHES

Backset	Faceplate Description	Deadlatch 1/2" Throw	Springlatch 1/2" Throw	Housing Diameter
2 3/8"	1" x 2 1/4", Square corner, standard	11-085	11-068	7/8"
	1" x 2 1/4", 1/4" Radius round corner	11-088	11-069	7/8"
	1" Circular, drive-in (non-U.L.)	11-104	11-110	1"
2 3/4"	1" x 2 1/4", Square corner	11-091	11-111	7/8"
	1 1/8" x 2 1/4", Square corner	11-096	11-116	1"
	1" x 2 1/4", 1/4" Radius round corner	11-092	11-112	7/8"
	1" Circular, drive-in (non-U.L.)	11-105	11-113	1"
3 3/4"	1 1/8" x 2 1/4", Square corner	11-103	11-118	1"
—	Rabbeted latch and strike kit	39-030		

## STRIKES

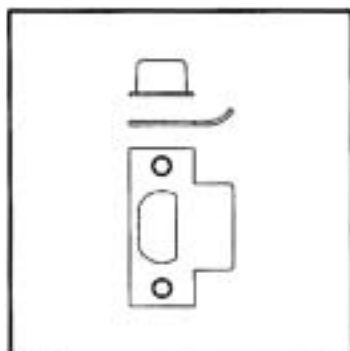

### 10-001 (Standard)

Square Corner

Size: 1 1/8" x 2 3/4" x 3/32"

Lip Length: 1 1/8" (Std), 1",

1 1/4", 1 1/2", 1 3/4", 2"

Includes C603-623 strike box

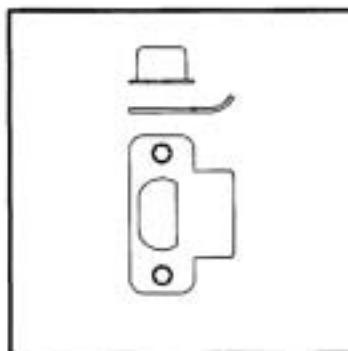

### 10-004

1/4" Radius Round Corner

Size: 1 1/8" x 2 3/4" x 3/32"

Lip Length: 1 1/8"

Includes C603-623 strike box

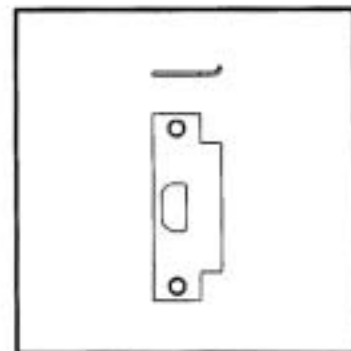

### 10-025

ANSI Prep. A115.2

Size: 1 1/4" x 4 7/8" x 3/32"

Lip Length: 1 3/16" (Std), 1 3/8"

If required, K510-066 strike box must be ordered separately.

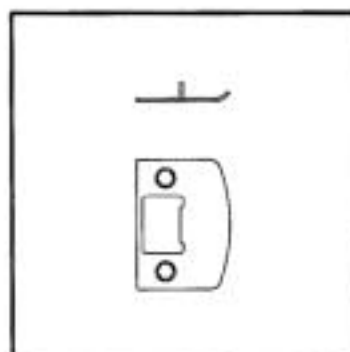

### 10-026

Full Lip, Square Corner

Size: 1 5/8" x 2 1/4" x 1/16"

Lip Length: 1 1/8"

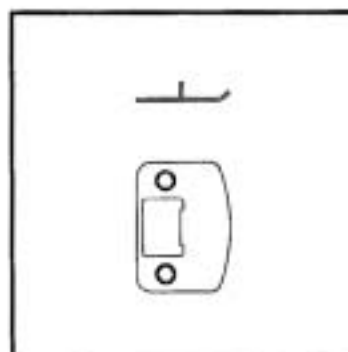

### 10-027

Full Lip, 1/4" Radius Round Corner

Size: 1 5/8" x 2 1/4" x 1/16"

Lip Length: 1 1/8"

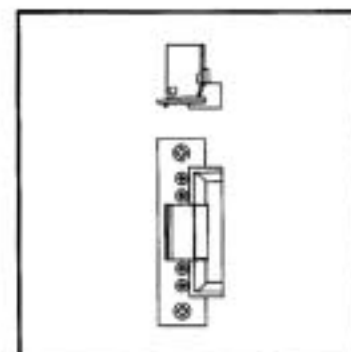

### 10-042

Electric Strike

Size: 1 1/4" x 4 7/8" x 3/32"

Voltage: 24VAC, 12VDC

Not designed for continuous duty and electrical locking.

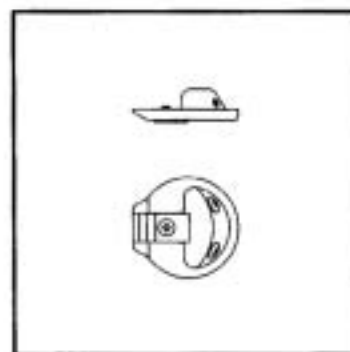

### 10-058

Circular Adjustable

Size: 1 3/4" Diameter

Lip Length: 1 7/32"

## OPTIONAL TAMPER RESISTANT TORX SCREW PACKS

Number	Description
C203-311	(4) Latch and Strike Screws, #8-32 x 1/2" (T-15)
C203-312	(2) Latch Screws, #8-32 x 1/2" (T-15) (2) ANSI Strike Screws, #12-24 x 1/2" (T-20)

## TORX TOOLS

Number	Description
M504-425	T-15 Torx Tool
M504-426	T-20 Torx Tool

## DESIGNS

Order by design code shown in parenthesis ( ).



Flair (FLA)



Levon (LEV)



Ventura (VEN)

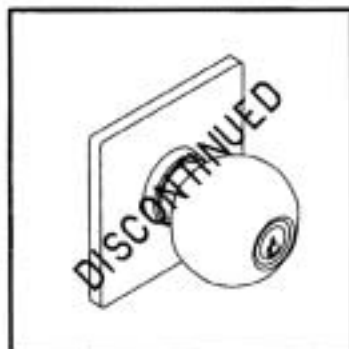

Comet (COM)

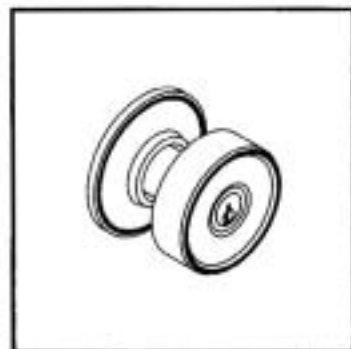

Crown (CRO)

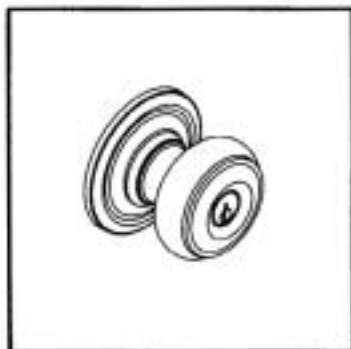

Georgian (GEO)

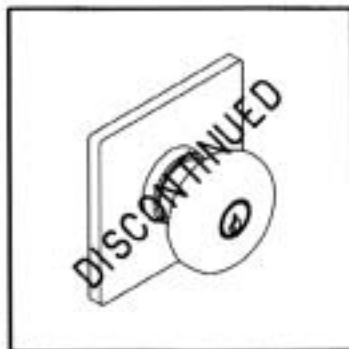

Hanover (HAN)



Luna (LUN)



Magnolia (MAG)

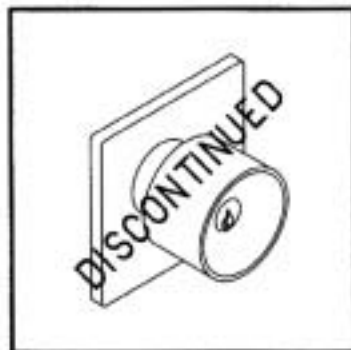

Meteor (MET)

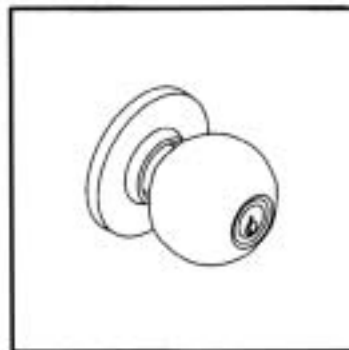

Orbit (ORB)

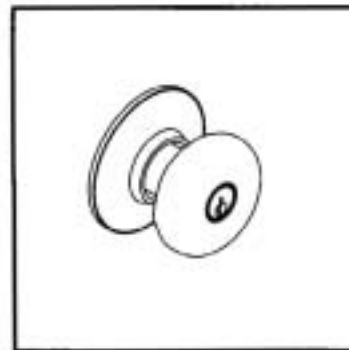

Plymouth (PLY)

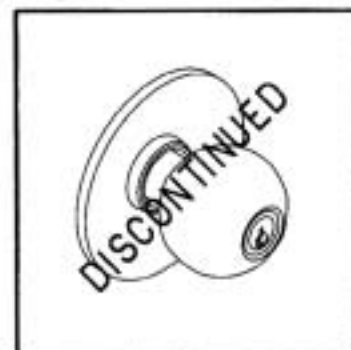

Planet (PLA)

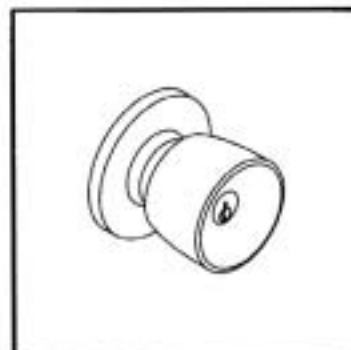

Tulip (TUL)

## FINISHES

Schlage Lock finishes are durable, top quality finishes obtained by the careful processing of solid brass, bronze, stainless steel or other materials. Where required, a protective clear coating is applied and cured under high temperature. It is important that climatic conditions and usage be taken under consideration when selecting finishes. This is especially true in areas subjected to strong corrosive vapors, humid climate or sea air, which, in a short time, may have a damaging effect on metal finishes.

The longevity and preservation of the finish appearance is determined by base metal and finishing process. Clear protective coating or other organic finishing applications may require different methods of cleaning and care. As an example, non-clear coated finishes should not be cleaned with soaps or any solvents; organically coated surfaces should periodically be cleaned with a mild non-abrasive soap and buffed lightly with a clean cloth. The type of base metal and finishing techniques must be considered when applying any cleaning or preservative method. Contact the Schlage Technical Services Department for further information on the care of finished hardware.

In some instances for customer convenience, the most appropriate BHMA finish symbols are used to indicate similarity of appearance regardless of base metal or finishing process. A-Series levers are zinc-based material and are plated to match finishes indicated. Finish numbers in the 600 Series are the BHMA (Builders Hardware Manufacturers Association) industry standard. The nearest old U.S. equivalent code designations are shown in parenthesis ( ).

Symbol	Description
412	BLACK, NON-SLIP Abrasive Coated (for PLY and ORB designs only)
605 (3)	BRIGHT BRASS Clear Coated
606 (4)	SATIN BRASS Clear Coated
609 (5)	SATIN BRASS, BLACKENED Satin Relieved, Clear Coated
610 (7)	BRIGHT BRASS, BLACKENED Bright Relieved, Clear Coated
612 (10)	SATIN BRONZE Clear Coated
613 (10B)	OIL RUBBED BRONZE Oxidized Satin Bronze, Oil Rubbed, No Coating
625 (26)	BRIGHT CHROMIUM PLATED No Coating
626 (26D)	SATIN CHROMIUM PLATED No Coating
630 (32D)	SATIN STAINLESS STEEL No Coating

## LUBRICATION

A-Series lock mechanisms are designed for durability and seldom need servicing. During assembly, those points of contact which require lubrication for ease of operation are given an application of high quality petroleum based grease. A touch of graphite is applied to the pin tumbler plug during assembly of the cylinder unit. No further servicing should be required for an extended period except where locks are subjected to extremely heavy traffic. Also, if located in particularly dusty or dirty areas, the grease may become contaminated resulting in a slow or otherwise unsatisfactory operation. The case mechanism should then be cleaned in a noncorrosive petroleum solvent and relubricated. Graphite only should be applied to the cylinder unit by blowing a small quantity into the keyway.

**Note:** Precautionary measures according to solvent manufacturers instructions should always be followed.

## INSTALLATION TOOLS AND KITS

Boring jigs and tools are designed to provide fast and accurate lock installation. Complete kits, contained in a heavy gage metal box, or individual tools can be ordered for preparing doors and jambs for Schlage products.

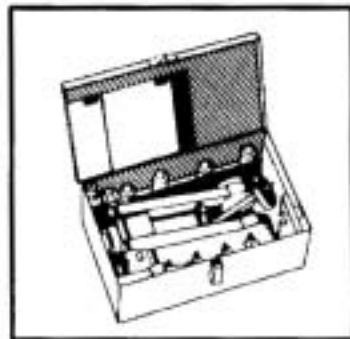

**40-055**  
Installation Kit  
For A, AL, D and F-Series Locks. Adjustable for 2 3/8", 2 3/4" and 5" backsets, Removable bushing adaptor for 7/8" latch hole. The boring jig integrates thru bolt hole locations for AL and D-Series levers. For door thickness 1 3/8" to 2 1/8".



**40-006**  
Installation Kit  
For A, AL, B, D, F, H and S200-Series locks. Adjustable for 2 3/8" and 2 3/4" backsets. Designed for special high speed hexagonal shank boring bits and equipped with an adaptor to form a integrated unit for boring doors 1 5/16" to 1 15/16" thick.

Number	Description
40-056	Boring Jig
40-015	7/8" Boring Bit
40-018	1" Boring Bit
40-024	2 1/8" Boring Bit
40-029	Strike Marking Chisel, Full Lip
40-030	Strike Marking Chisel
40-031	Latch Marking Chisel, A,F,H
40-032	Latch Marking Chisel, B,D,H
40-035	Strike Locator, 7/8"
40-036	Strike Locator, 1"
40-041	4" Bit Extension
40-050	Tool Box
40-057	5/16" Boring Bit
M507-347	Socket Wrench

Number	Description
40-012	Boring Jig
40-016	7/8" Boring Bit
40-019	1" Boring Bit
40-025	2 1/8" Boring Bit
40-026	1 1/2" B-Series Bushing
40-028	1 1/2" Boring Bit
40-029	Strike Mrk. Chisel
40-030	Strike Mrk. Chisel
40-031	Latch Mrk. Chisel
40-032	Latch Mrk. Chisel
40-035	Strike Locator
40-036	Strike Locator
40-039	Boring Bit Adapt.
40-042	Backset Peg
40-049	Tool Box
M504-265	Jig Replacement Bushing

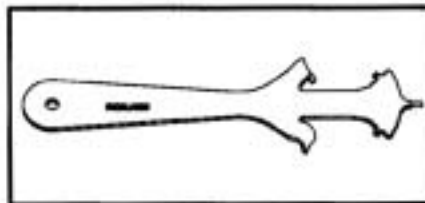

**M504-310**  
Spanner wrench

For tightening inside threaded roses and depressing knob catches on A and D-Series locks.

## LONG BACKSETS

Backsets 5" and over require extension links. A-Series locks with long backsets are normally furnished with 1" faceplates and 7/8" housings. Links installed in 1" latch holes require one G506-815 sleeve (order separately) to join latch and link. Backsets over 5" require an additional sleeve placed 1/8" from lock chassis. Information on longer backsets is available upon request.

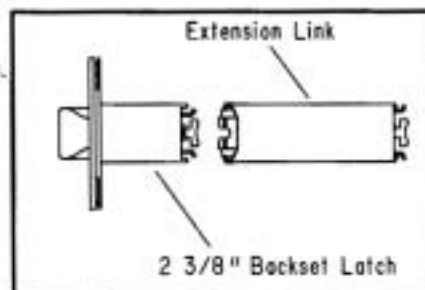

**41-005**  
5" Extension Link

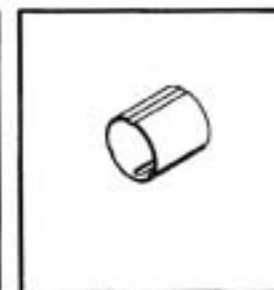

**G506-815**  
Sleeve

## REINFORCEMENT KIT

The Schlage 37-001 reinforcement kit is to reinforce and help prevent the collapse of hollow metal doors when locksets are tightly mounted. This kit should be used with long backsets for installations in hollow metal doors to prevent lateral movement of latch bolt. Specify door thickness 1 3/8" or 1 3/4" when ordering.

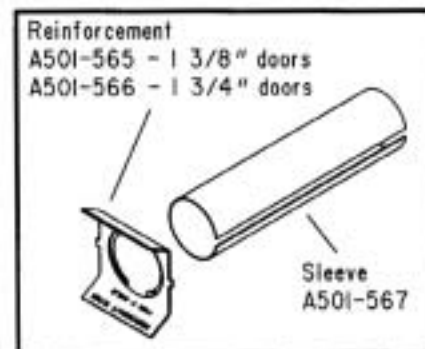

**37-001**  
Reinforcement Kit

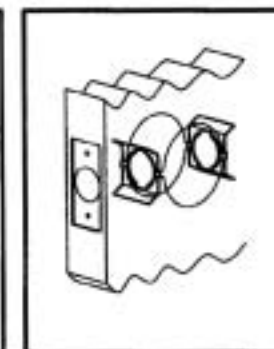

Placement of reinforcements in hollow metal door.

## KEYING

### Key Array Chart

The Schlage Masterkey Department determines and makes the final decision in the selection and use of key sections. Other keyways, than shown below, are available. Allocation of other keyways is based on need and extent of the final system. Priority is given to key systems that require a large number of cylinders and families of key sections to satisfy their keying requirements. Contact your Schlage representative for availability of other keyways.

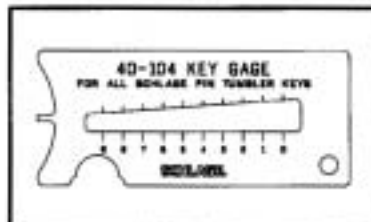
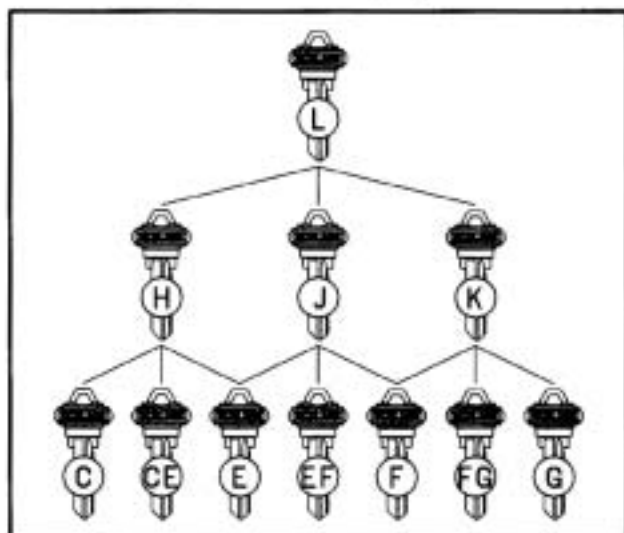

**Key Gage**  
40-104

Order the Schlage key gage to accurately measure the depth of key cuts.

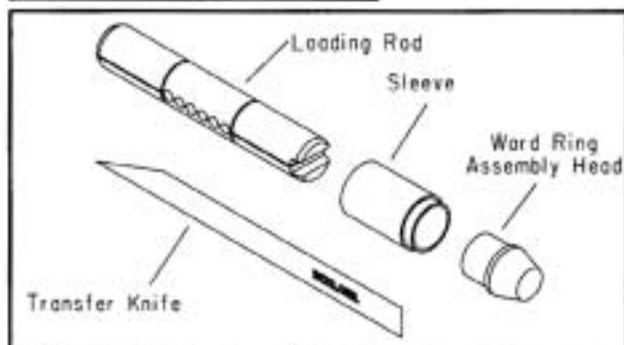

**Cylinder Body Loading Tool**  
40-116

A compact precision tool for loading top pins and springs and for installation of ward rings into grooves of a warded cylinder plug. Furnished with complete assembly instructions.

### Pin Tumbler Keys

All Schlage locks come with two nickel silver keys as standard, embossed with our company logo. The nickel silver alloy from which all Schlage keys are made provides the base for accuracy in cutting and long cylinder wear. Schlage will stamp "DO NOT DUPLICATE" across the bow of all versions of its keys at no extra charge, when specified on orders.

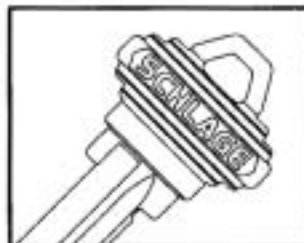

**Embossed Both Sides**  
35-100 (5 Pin standard)  
35-101 (6 Pin)

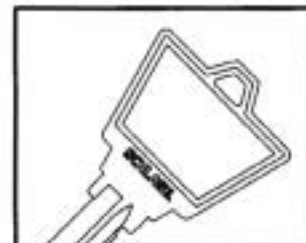

**Large Bow**  
35-140 (5 Pin)  
35-141 (6 Pin)



**Stamped One Side**  
35-120 (5 Pin)  
35-121 (6 Pin)



**Access Bow**  
35-143 (5 Pin\*)  
35-144 (6 Pin)  
\*Available in C,E,F, and CE Only



**Plain**  
35-130 (5 Pin)  
35-131 (6 Pin)

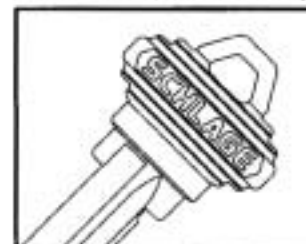

**Hotel Emergency Key**  
35-102 (6 Pin)



**Emergency Key**  
A40 Function  
35-250

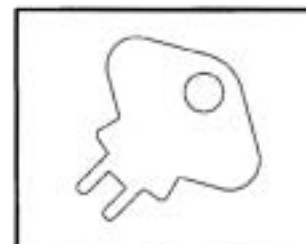

**Spanner Key**  
A85 Function  
35-251

## MODEL MAB4 PLUNGER INSTALLATION

Note: These instructions are for installation of plunger and button for model MAB4 A-Series locks. Model MA45 locks may need replacement of additional parts, as indicated in the instructions.

### Outside Plunger Assembly

Functions A40S and A44S

#### Disassemble Lock

1. Depress knob catch and remove inside knob.



2. Position screw driver into slot on edge of rose and snap off rose.



Unscrew mounting screws and remove inside mounting plate.

3. Straighten and remove cotter pins. Rotate housing slightly in either direction and remove from lock chassis.

#### Remove Cotter Pins & Housing



4. Depress slide, unhook and remove both inside plunger and spindle.

#### Unhook & Remove

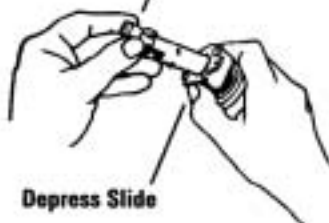

Depress Slide

5. Remove hub plate. (Hold palms of hands around lock to prevent springs from escaping slide.) Press forward with thumbs against frame tabs while pushing upward with index finger to disengage plate.



6. Remove slide and springs. If necessary to remove outside hub plate, rotate knob 180° to remove.



Turn and pull outside knob and spindle from lock frame. (If replacing parts from model M45 lock, discard old outside knob, spindle and keyway.) If necessary, change outside hub plate.

#### Outside Button and Bar Assembly

7. Insert new outside spindle thru lock frame from inside of frame. Also insert new keyway.



Re-position hub plate, slide and springs in frame.

8. Place new bar (less button assembly) into position thru spindle and into lock frame. Make sure that bar engages keyway in outside spindle.



9. Place new plunger button assembly onto plunger bar and snap firmly into bar.



Slide new knob onto spindle, depress knob catch and push knob into place until knob catch engages in slot on knob.

#### Lock Assembly

10. Reverse steps to reassemble complete lock and trim.



## Outside Plunger Assembly

Function A43D

### Disassemble Lock

1. Rotate thumbturn 60° to expose and remove mounting screws. Remove lock from door.
2. Depress knob catch and remove knob.



3. Follow previous steps 3 thru 6 for disassembly of chassis.

### Outside Button & Bar Assembly

4. Insert new outside spindle and plunger assembly thru lock frame from inside of frame.



- Re-position hub plate, slide and springs in frame.

5. Slide knob onto spindle, depress knob catch and push knob into place until knob catch engages in slot on knob.

### Lock Assembly

6. Reverse steps to reassemble complete lock and trim.

## Inside Plunger Assembly

Functions A30D, A40S, A44S, A53PD, A55PD, A73PD and A85PD

1. Depress knob catch and remove inside knob.



2. Position screw driver into slot on edge of rose and snap off rose.



3. Unscrew mounting screws and remove inside mounting plate.

4. Straighten and remove cotter pins. Rotate housing slightly in either direction and remove from lock chassis.

### Remove Cotter Pins & Housing

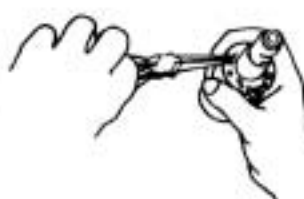

5. Depress slide, unhook old plunger by lifting, remove both plunger and spindle.

### Unhook & Remove



Depress Slide

6. Insert new plunger bar (less button assembly), depress slide and push plunger bar while releasing slide to hook into place.

### Insert Bar



7. Install new spindle over bar, rotate slightly and push into place. (Slot on spindle should be on same side as slide jaws.)

### Spindle

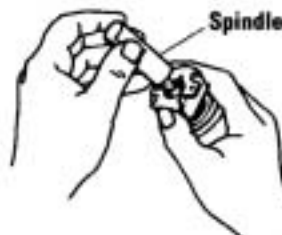

8. Align plunger button assembly so lug fits into slot on spindle. Position plunger button assembly onto bar and snap firmly into place.

### Snap On Button



## INSTALLATION INSTRUCTIONS

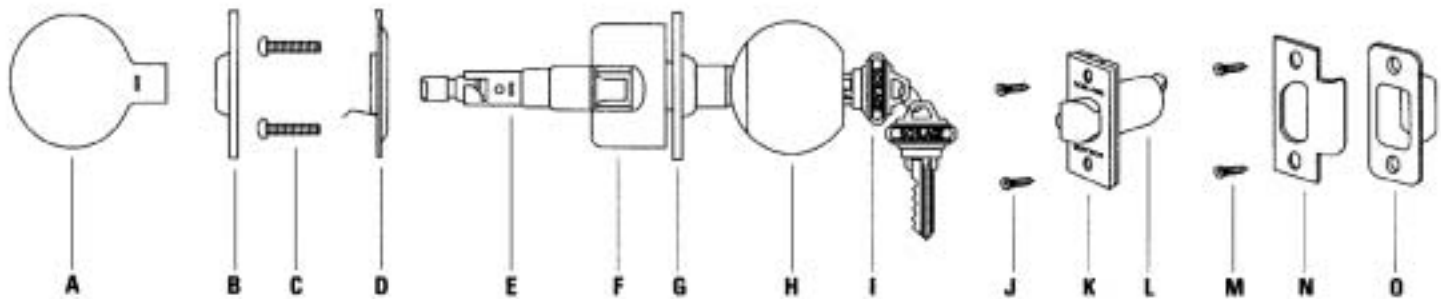

A. Inside knob  
B. Inside rose  
C. Mounting screws

D. Mounting plate  
E. Spindle  
F. Lock housing

G. Outside rose  
H. Outside knob  
I. Keys (2)

J. Latch screws  
K. Faceplate  
L. Latch

M. Strike screws  
N. Strike plate  
O. Strike box

### 1

**NOTE:** When replacing an old lock, make sure that the lock hole is 2 1/8" (54mm) in diameter. If necessary use a wood rasp to increase size of hole.

#### Mark door

Place template on door and mark drill points for (2) holes. (Suggested height for center of lock hole is 38" (97mm) from floor. Template should be placed on high edge of beveled (slanted) door edge.

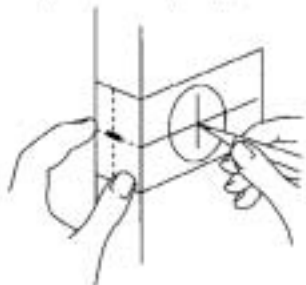

**NOTE:** A-Series locks are normally extended for doors as thick as 1 3/4" (48mm). For thicker doors (special ordered locks), mark latch hole 3/4" (19mm) from outside face of door.

### 2

#### Drill holes

Drill a 2 1/8" (54mm) hole through door. (Drill from both sides of door to avoid wood damage.) Drill a 3/4" (22mm) or a 1" (25mm) hole (depending on latch housing diameter) in edge of door.

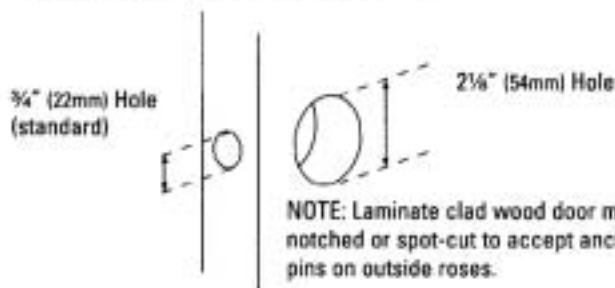

**NOTE:** Hollow metal doors must be properly reinforced for latch support. If door reinforcement is not furnished, contact door manufacturer or use Schlage reinforcer #37-001 (specify door thickness).

### 3

#### Install latch

**A.** Insert latch. Trace around faceplate for cutout. Use chisel to remove wood until faceplate fits flush with door edge. Install latch so that beveled side of bolt faces door jamb. Fasten to door with screws.

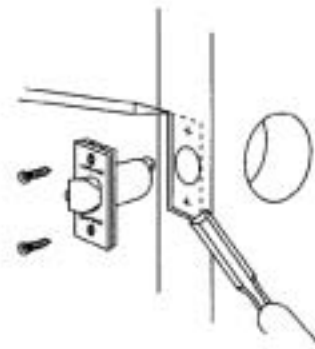

**B.** For circular latch, line up latch so that flat side is vertical. Place wooden block against latch. Tap lightly with mallet or hammer to drive latch into hole. Surface of faceplate should be flush with door edge.

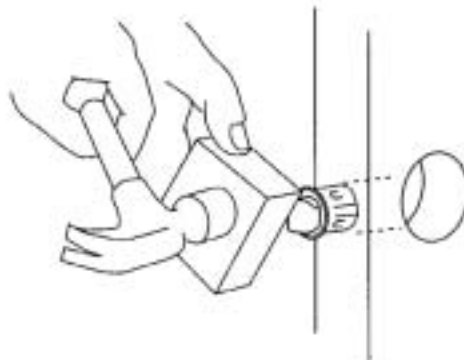

## INSTALLATION INSTRUCTIONS

**4**

### Prepare door jamb

**A.** Locate and mark height and centerlines on door jamb exactly opposite center of latch hole.

**B.** For T shape strike, drill (2)  $\frac{7}{8}$ " (22mm) overlapping holes  $\frac{1}{16}$ " (17mm) deep,  $\frac{3}{8}$ " (10mm) above and below centerline. Clean out hole for latch clearance. Use strike as pattern for cutout.

**C.** Install plastic dust box and strike.

### T Strike

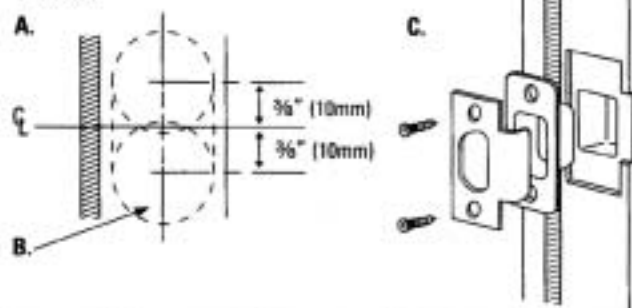

### Full lip strike

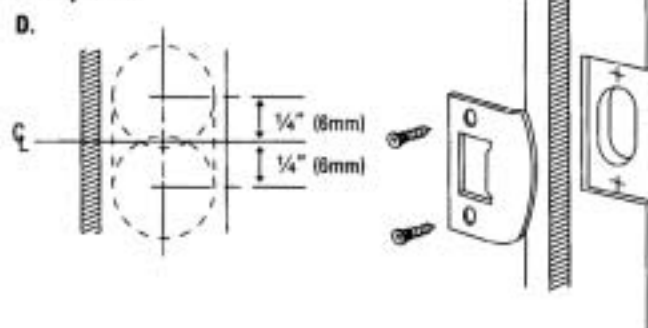

**D.** For (optional) full lip strike, drill (2)  $\frac{7}{8}$ " (22mm) overlapping holes  $\frac{1}{16}$ " (17mm),  $\frac{1}{4}$ " (6mm) above and below centerline. Clean out hole for latch clearance. Use strike as pattern for cutout. Install strike.

**IMPORTANT:** Deadlocking plunger on latchbolt must stop against strike to prevent forcing of latch when door is closed.



**5**

### Install lock

**CAUTION:** Do not attempt to install lock with door closed.

**A.** Depress knob catch; slide off inside knob.

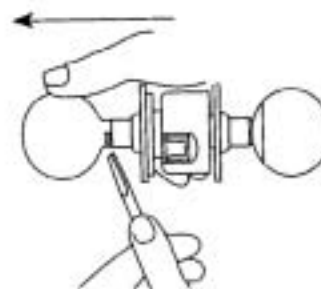

**B.** Remove rose.

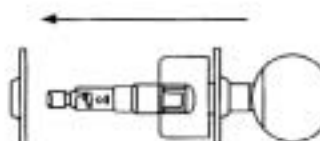

**C., D.** If necessary, rotate outside rose to center lock housing in door width.

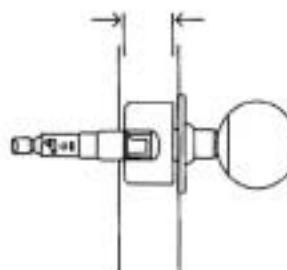

**E.** Insert lock into outside knob hole. Look through inside hole to make sure latch is correctly engaged.

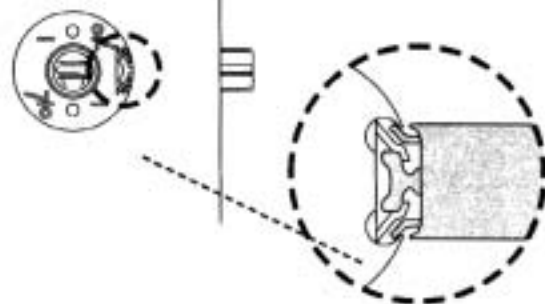
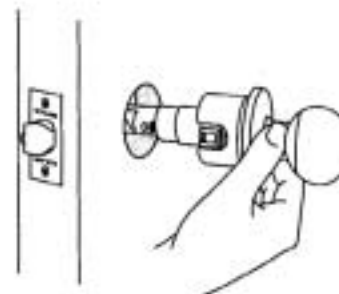

## INSTALLATION INSTRUCTIONS

6

### Attach Inside Trim

- A.** Install mounting plate (catch spring in lower position as shown). Align notch on rose with spring and snap onto mounting plate.  
**B.** Depress catch and install knob.

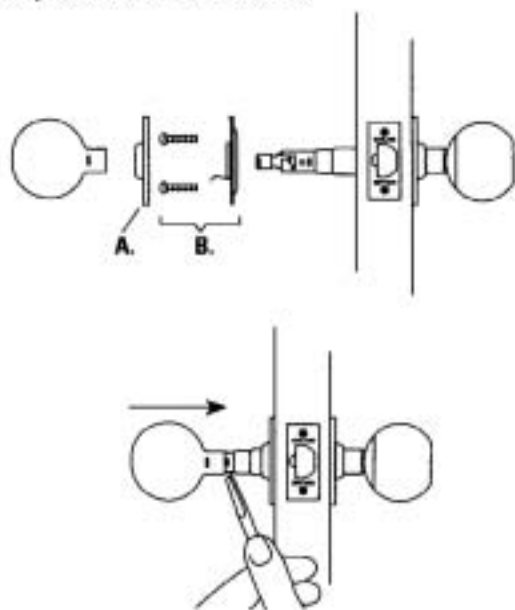

### Interchangeable Core Cylinder

Follow Step 7 for removing knob. CORE MUST NOW BE REMOVED FROM KNOB BEFORE REPLACING ON LOCK. Insert control key and turn 15° to the right until action stops. Pulling on key will now extract core from knob.

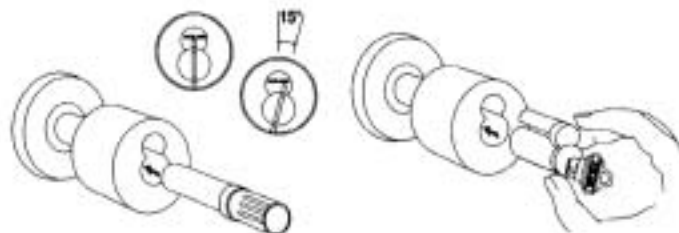

Turn knob over and replace knob on spindle. Slide knob up to knob catch. Insert long end of installation tool into knob until it engages driver. Turn tool one-quarter turn to right, depress knob catch and push knob into position. With control key fully inserted, push core into knob housing, rotate key 15° to the right and insert core completely. Rotate key back to upright and remove control key.

7

### Check Keyway Position

- To change keyway position:  
**A.** With door locked, turn key.  
**B.** Insert pointed tool into hole in knob shank; exert pressure to depress catch.  
**C.** Pull to remove knob.  
**D.** With key halfway out, turn knob over and slide back on spindle.  
**E.** Insert key, rotate, depress knob catch and push to install. Pull knob to make sure catch is engaged.

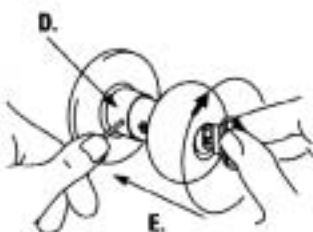
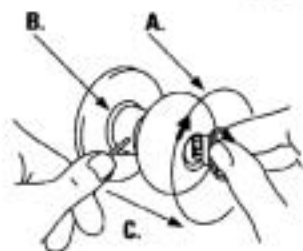

## INTERCHANGEABLE CORE RETROFIT KIT INSTRUCTIONS

### A-Series Kit:

Knob  
Driver  
Retainer  
Interchangeable  
Core

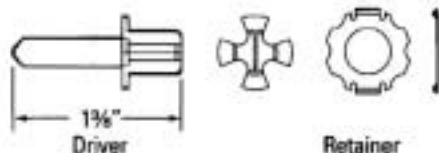

### D-Series Kit:

Knob or Lever  
Driver  
Retainer  
Interchangeable  
Core

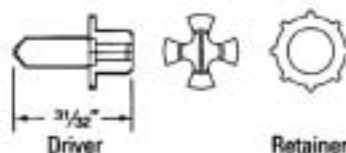

Installation Tool  
(Order Separately)

**1**

### Remove Knob or Lever and Cylinder

To remove existing knob or lever from lock assembly, insert pointed end of spanner wrench\* or small nail into hole in hub cap (A-Series), knob sleeve (D-Series knobs) or lever (D-Series levers). Exert pressure on wrench while turning key slowly until knob catch depresses and pull off knob or lever.



\* Spanner wrench normally furnished with locks using threaded roses.

**3**

### Install Interchangeable Core Knob or Lever

Slide knob or lever onto spindle up to knob catch. Insert smooth end of tool through core opening in knob or lever and turn tool until it engages the driver. Insert pointed end of spanner wrench or similar tool into hole in hub cap (A-Series) or on knob catch (D-Series knobs). Turn installation tool clockwise, exert pressure on spanner wrench until knob catch depresses (not required for D-Series levers) and push knob or lever into place. Pull on knob or lever to be sure catch is engaged.

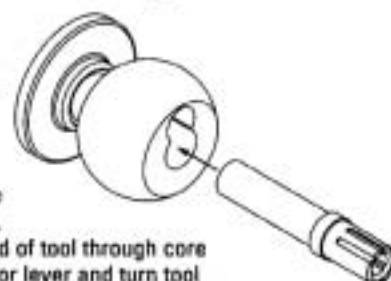

**2**

### Install Interchangeable Core Driver and Retainer

Note: Illustration is for A-Series locks. Use smooth end of installation tool for D-Series locks.



Place retainer and driver on end of installation tool as shown. The bent tabs of the A-Series retainer must be angled away from the driver and must line up with the top and bottom slots in the spindle. Install the driver so the timing line is horizontal, or parallel with the latch. Insert installation tool into spindle and push in until it stops. Remove installation tool.

**4**

### Install Interchangeable Core

With control key fully inserted, push core into knob or lever housing, rotate key 15° clockwise and insert core completely. Remove control key.



## DOOR HANDING

All Schlage locks are reversible. However, the correct hand should be specified for all pin tumbler locks so that they may be assembled to assure key cuts are in the upright position. Hand information is also necessary to ensure proper finish of latchbolt and strike for locks ordered that are to be installed on reverse bevel doors. Follow the diagram to correctly determine the hand of the door.

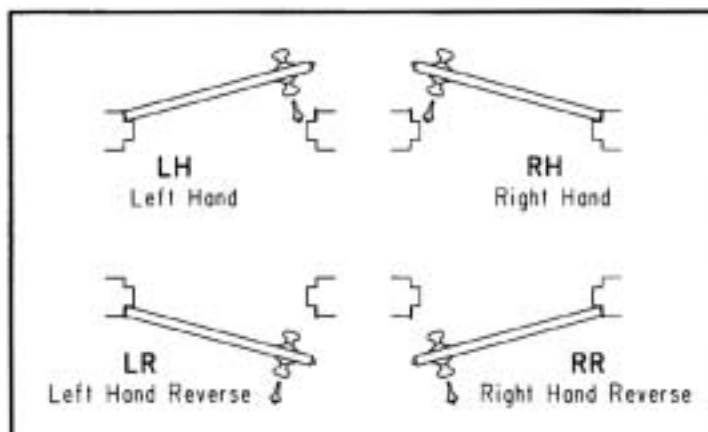

## ORDERING PROCEDURES

To order Schlage products, descriptive data should be in the same sequence as shown.

Line Item	Qty	Product	Outside		Inside		Hand	Latch	Strike	Dr Thk	Ext	Dim	Additional Details
			Des	Fin	Des	Fin							
1	2	3	4	5	6	7	8	9	10	11	12	13	14

- Line item number.
- Quantity.
- Complete lock product or part number.
- Outside design code.
- Outside finish code.
- Inside design code. Leave blank if same as outside design code.
- Inside finish code. Leave blank if same as outside finish code.
- Hand of door. Only one hand allowed per line item. Example: RH=Right Hand, LH=Left Hand, RR=Right Reverse, LR=Left Reverse.
- Latch. Leave blank for standard or specify part number if non-standard latch is required. LLL=Less latch.
- Strike. Leave blank for standard or specify part number if non-standard strike is required. LLL=Less Strike.
- Door Thickness. Enter door thickness if non-standard. Example: 138= 1 3/8", 214= 2 1/4", 212= 2 1/2".
- Extension. Enter one of the following when doors 2" thick or greater are specified:  
 EE = Extended Equally,  
 EI = Extended Inside,  
 EO = Extended Outside,  
 ED = Extended Differently.  
 EI or EO assumes the latch will be centered on a 1 3/4" thick door, to which material has been added.
- Enter dimension for non-standard strike lip length and mortise cylinder or blocking ring length.  
 Example:  
 012 = 1/8"      118 = 1 1/8"  
 018 = 3/16"    114 = 1 1/4"  
 025 = 1/4"      138 = 1 3/8"  
 031 = 5/16"    112 = 1 1/2"  
 037 = 3/8"      158 = 1 5/8"  
 050 = 1/2"      134 = 1 3/4"  
 078 = 7/8"      200 = 2"  
 100 = 1"        400 = 4"
- Enter detail for keying information and for special requirements.

## ORDERING EXAMPLES

Line Item	Qty	Product	Outside		Inside		Hand	Latch	Strike	Dr Thk	Ext	Dim	Additional Details
			Des	Fin	Des	Fin							
1	50	A53PD	PLY	626			RH	11-096	10-025				KEYED C000000
2	50	A53PD	PLY	626			LH	11-096	10-025				KEYED C000000
3	5	A80RD	ORB	612	PLY		RH			212	EI	200	KEYED E111111
4	10	A40S	GEO	609		625			10-026				W/41-005 EXT. LINK
5	12	A53LD	ORB	605									LESS CYLINDER
6	12	20-524		606								122	

**NOTE:** Schlage order forms are available at no charge by contacting your Schlage Representative or Customer Service.

## LIMITED WARRANTY

Schlage Lock Company (the "Company") warrants to the original purchaser that the products manufactured by it (the "Product") to be free of defects in material and workmanship. Provided: (i) The Company has been notified within one year of purchase date and been given the opportunity of inspection by return of any alleged defective Product to the Company, or its authorized distributor, at the address specified herein, free and clear of all liens and encumbrances, transportation prepaid, accompanied by the statement of defects and proof of purchase; and (ii) The Product has not been modified, abused, misused, or improperly installed, maintained and/or repaired during such period; and (iii) Such defect has not been caused by corrosion or ordinary wear and tear.

THE COMPANY MAKES NO OTHER WARRANTY, AND ALL IMPLIED WARRANTIES INCLUDING ANY WARRANTY OF MERCHANTABILITY OR FITNESS FOR A PARTICULAR PURPOSE ARE LIMITED TO THE DURATION OF THE EXPRESSED WARRANTY PERIOD AS SET FORTH ABOVE.

THE COMPANY'S MAXIMUM LIABILITY HEREUNDER IS LIMITED TO THE PURCHASE PRICE OF THE PRODUCT. IN NO EVENT SHALL THE COMPANY BE LIABLE FOR ANY CONSEQUENTIAL, INDIRECT, INCIDENTAL OR SPECIAL DAMAGES OF ANY NATURE ARISING FROM THE SALE OR USE OF THIS PRODUCT, WHETHER IN CONTRACT, TORT, STRICT LIABILITY OR OTHERWISE.

### NOTE:

Should the Product be considered a consumer product as may be covered by the Magnusson Moss Federal Warranty Act, please be advised that: (1) Some states do not allow limitations on incidental consequential damages or how long an implied warranty lasts so that the above limitations may not fully apply; (2) This warranty gives specific legal rights and a buyer may also have other rights which may vary from state to state. For warranty service and shipping instructions, contact the Schlage Lock Company:

**Schlage Customer Service Department**  
2000 Sierra Point Parkway  
Brisbane, CA 94005-1850  
(800) 847-1864  
Fax (800) 452-0663

The Schlage Lock Company reserves the right to make changes in designs and specifications or to make additions or improvements on its products without notice and without incurring any obligation to incorporate them on products previously manufactured. The Schlage Lock Company is not responsible for any modification, addition or alteration to our products by others.

**NOTES**





**NOTES**

## NOTES



---

### **Administrative Offices**

1915 Jamboree Drive  
Colorado Springs, CO 80920  
(719) 264-5300  
FAX (719) 264-5382

### **Commercial Customer Service**

2000 Sierra Point Parkway  
Brisbane, CA 94005-1850  
(800) 847-1864  
FAX (800) 452-0663  
FAX (800) 616-6040  
Order Entry  
(800) 452-0665

### **Technical Services**

3899 Hancock Expressway  
Security, CO 80911  
(800) 847-1864  
FAX (719) 390-2682

### **International Division**

Ingersoll-Rand Architectural Hardware  
1076 Lakeshore Road East  
Mississauga, Ontario, L5E 1E4, Canada  
(905) 278-6128  
FAX (905) 278-1413

### **Internet**

<http://www.schlage.com>

