

## Strikes

### 4800 Series, 4803, 4806, MS4804

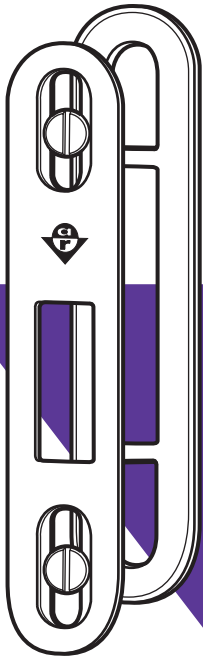

4801-01  
with Shim

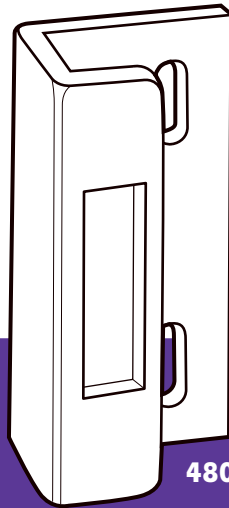

4803

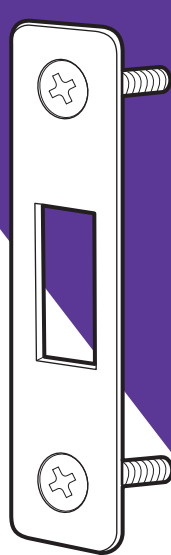

MS4804

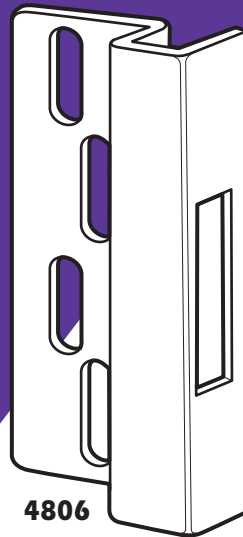

4806

#### 4800 Series

##### Function

With vertical adjustment to accommodate door/jamb misalignment and a shim system for horizontal positioning to match various jamb bumper designs, 4800 Series strikes can be fit to nearly any sliding door using a mortised MS1847 Series lock or latch. 4801 strikes are furnished with sheet metal screws for metal jamb installation. 4802 strikes are furnished with machine screws and tee nuts which are installed on the back side of jamb to provide the strongest possible anchorage in wood.

##### Material

Steel, heat treated. Shims are ABS plastic. Zinc (603) finish. For other finishes contact factory.

#### MS 4804

##### Function

Provides a strike equal to the strength of the stainless steel bolt of the MS1847 Deadlock: tested to 1,000 lbs. of force. This strength exceeds by far the standards of the Architectural Aluminum Manufacturers Association as well as the strictest current municipal security ordinance.

##### Faceplate

1/16" x 3/4" x 3-3/8". Steel, plated for corrosion resistance. MS4804-10 available in Stainless Steel.

##### Reinforcing Plate

1/16" x 1/2" x 3-3/8". Steel, plated for corrosion resistance. Tapped for furnished #10-32 flathead screws.

#### 4803

##### Function

A nearly universally usable strike for the 4035 lock, the 4803 strike is fastened to the door jamb by two screws. Vertical adjustment of .25 inch is provided to allow perfect engagement of the lock bolt despite door misalignment or in-place settling.

##### Material/Finish

Steel, Zinc (603) plated.

#### 4806

##### Function

Surface mounted strike for 4035 lock. Fastened to side of jamb by two screws. Vertical adjustment of .25 inch plus extra mounting holes for convenience of mounting or adding screws for increased strength.

##### Material/Finish

Type 301, Satin Stainless, 630 (US32D).





# 4800 Series, 4803, 4806, MS4804 Strikes

## DIMENSIONS

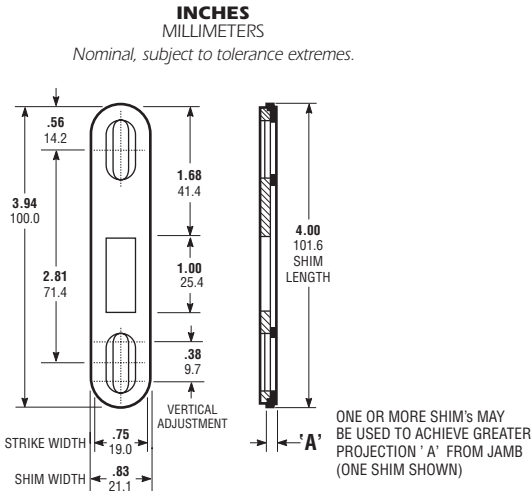

### 4800 Series

PART NO.	SHIMS	DIMENSION 'A'	APPLICATION
4801	None	0"	METAL JAMBS (Furnished with two #8 x 1 sheet metal screws.)
4801-01	1	3/32" 2.4	
4801-02	2	3/16" 4.8	
4801-03	3	9/32" 7.1	

PART NO.	SHIMS	DIMENSION 'A'	APPLICATION
4802	None	0"	WOOD JAMBS (Furnished with two #8-32 x 7/8 machine screws and two tee nuts.)
4802-01	1	3/32" 2.4	
4802-02	2	3/16" 4.8	
4802-03	3	9/32" 7.1	

## INSTALLATION

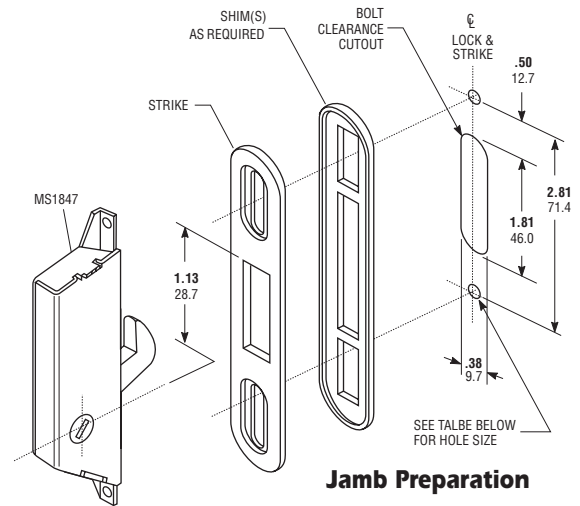

	HOLE SIZE
METAL JAMB APPLICATION <b>4801 SERIES</b>	<b>.120</b> (No. 31 DRILL) 3.0
WOOD JAMB APPLICATION <b>4802 SERIES</b>	<b>.213</b> (No. 3 DRILL) 5.4

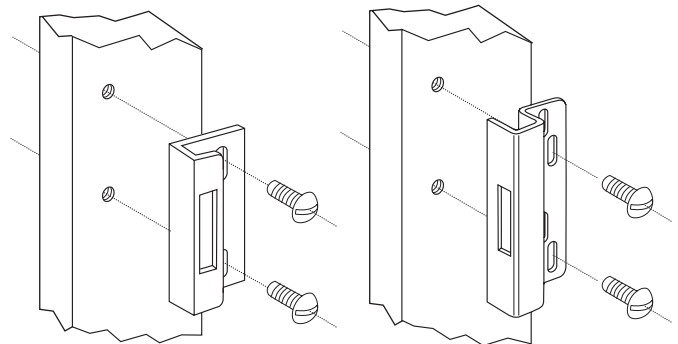
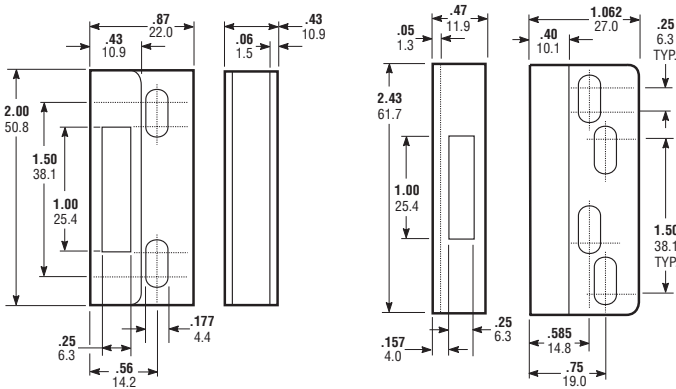

4803

4806

4803

4806

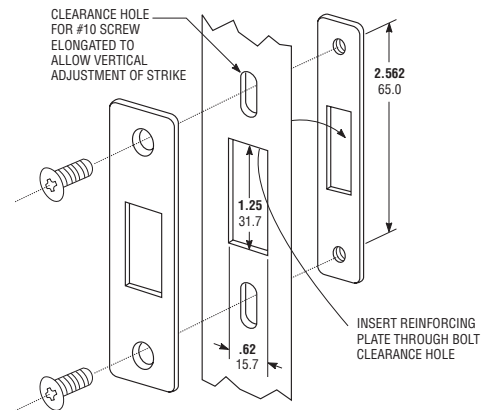
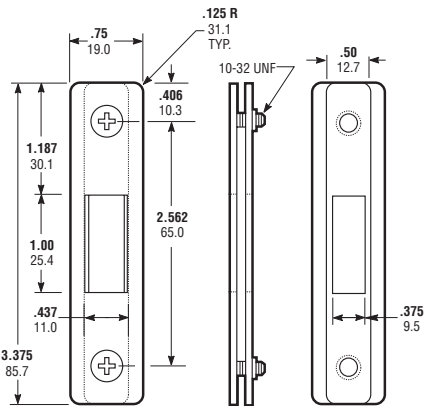

## HOW TO ORDER

Specify quantity and Part Number.  
Add dash number for 4800 Series (See table above).  
Order related hardware separately.

## STANDARD PACKAGE

All strikes are individually packaged in envelope with screws and shim if required.