

CompX[®]

NATIONAL



STOCK[®]
LOCKS[®]
Standard Locks for Special Needs

STOCK[®] LOCKS

Through your CompX National distributor . . . a program to meet your lock requirements.

CompX National manufactures a wide variety of locks for residential, commercial and industrial use. We've been solving security problems since the need for metal cabinet locks brought about the founding of our company in 1903.

The locks shown in this catalog are particularly well-suited to serve the replacement market...as well as component manufacturers. They have been proven in use.

Our experience in serving this market has shown us the importance of product quality, competitive pricing, proper packaging and immediate service and delivery. Working through your CompX National distributor, we offer a program that is committed to serving your needs.

A complete selection of locks

- Door and drawer locks for virtually every application, every security requirement.
- Mail box locks for extra profit, as well as protection.
- Locking devices of every description for use in schools, institutional and commercial buildings.
- Key blanks and keying kits to complement each of our locks.

Packaged for your convenience

- All hardware is individually packed in see-thru poly-bags for product protection and easy inspection.
- Poly-bags of like hardware are grouped in popular quantities and placed in handy cases.
- Case designed for convenience in storage and ease in handling.
- Cases are labeled for quick identification.



ASSOCIATE
MEMBER



ASSOCIATE
MEMBER



ASSOCIATE
MEMBER



how cabinet locks are used

DOOR APPLICATION

Bolt or cam at side locks to frame.

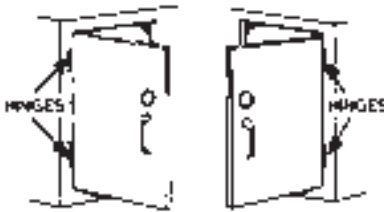

LEFT HAND

RIGHT HAND

At which edge of door hinges are located determines hand of door when facing door.

LID APPLICATION

Lock engages strike mounted on under-side of lid.



SLIDING (By-pass) DOOR APPLICATION

Lock engages strike mounted on rear door.

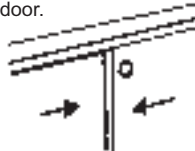

SINGLE DRAWER APPLICATIONS

Drawer mounted lock – Bolt or cam locks on frame.

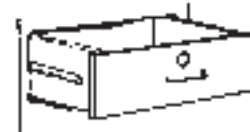

Frame mounted lock – Cam locks on back of drawer front with hook cam engaging strike.

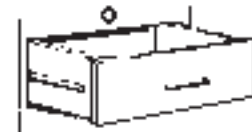

MULTIPLE DRAWER APPLICATIONS (Wood construction)

PEDESTAL/FILE

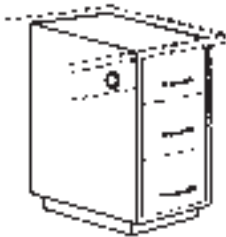

Side mounted gang lock – vertical bar movement locks all drawers simultaneously.

DESK

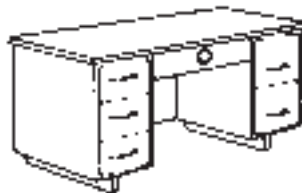

Center drawer mounted lock – Bolt locks on frame or top. Side drawer mechanism(s) actuated by locked center drawer secures drawers.

PEDESTAL/FILE

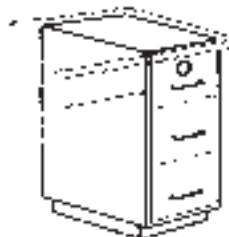

Top drawer mounted lock activates side mechanism securing other drawers.

LATERAL FILE

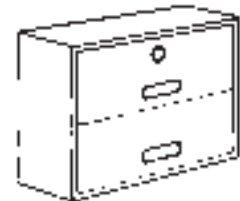

Top drawer mounted lock activates side mechanisms securing other drawer(s); also allows only opening one drawer at a time.

finish codes

Finish code applies to exposed portions of lock and is indicated by part number suffix, i.e.: C8053-3 Bright Brass finish.

2C–Zinc Plated	4G–Antique Brass	26–Bright Chrome
3–Bright Brass	14A–Bright Nickel	26D–Dull Chrome
4–Satin Brass	19–Black	(brushed)

key codes

Key codes stamping may appear with or without zeros preceding other numbers, i.e.: C001A and C1A are the same key code.

table of contents

Description	Page
Cams	17 & 23
Cam Locks	5, 7, 12 & 13
Center Drawer Locking Hardware	18
Chest Locks	19
Circuit Breaker Cabinet Lock	21
Code Books	25
Cooler Locking Handle	21
Desk Locks	6, 10, 11, 14, 16 & 17
Disc Tumbler Locks	11-21
Door & Drawer Locks	6, 7, 10, 11, 14, 16, 17 & 22
File Cabinet Locks	10 & 11
Furniture Locks	14-19
Gang Locks	14, 16 & 17
Garage Door Lock	21
Handle Locks	20
Interchangeable Cylinder Locks	6 & 7
Key Blanks	24 & 25
Key Hole Escutcheon	22
Keying Kits and Parts	26

Description	Page
Knob Locks	10
Lateral File Locking Hardware	18
Lever Tumbler Locks	22
Lid Locks	19
Locker Locks	22
Mail Box Locks	8 & 9
Master Keys	25
Pedestal Locking Hardware	16, 17, & 18
Pin Tumbler Locks	5-10
RemovaCore Furniture Locks	15-17
Sample Boards	27
Screwdriver Cam Latch	13
Springs	26
Sliding Door Locks	10 & 11
Showcase Locks	10
Strikes	22
Tumblers	26
Warded Barrel Key Locks	19

numerical index

Part No.	Page	Part No.	Page	Part No.	Page	Part No.	Page	Part No.	Page
V69B-1	27	C3758	26	C7104	23	C8174	6	C8751	20
V69B-2	27	C3759	26	C7105	23	C8175	6	C8754	20
V69B-3	27	D4290	24	C7110	23	C8177	6	C8755	20
V69B-4	27	D4291	24	C7111	23	C8178	6	C8756	20
V69B-5	27	D4292	24	C7112	23	C8179	6	C8757	20
V69B-6	27	D4293	24	C7113	23	C8183	7	C8758	20
V69B-7	27	D4295	24	C7114	23	C8188	7	C8759	20
V69B-8	27	D4296	24	C7115	23	D8192	25	C8762	21
V69B-10	27	D4297	24	C7116	23	D8193	25	C8763	21
V69B-12	27	D4299	25	C7163	7	D8194	25	C8764	21
V69B-13	27	D6676	26	D8001	25	C8207	19	C8765	21
V70P-1	26	D6680	26	D8002	25	C8252	19	D8776	24
V70P-2	26	D6682	26	C8042	11	C8253	19	D8777	24
V71D-3	26	D6686	26	C8043	11	C8384	19	D8778	24
V71D-4	26	C6782	26	C8046	11	C8402	22	D8779	15
C2001	22	C6783	26	C8047	11	C8410	22	D8780	24
C2002	22	C6784	26	C8051	12	C8414	19	D8781	24
C2003	22	C6785	26	C8052	12	D8419	25	D8782	24
C2004	22	C6786	26	C8053	12	C8422	22	D8783	24
C2005	22	C6787	26	C8054	12	D8490	25	D8784	24
C2006	22	C6788	26	C8055	12	D8491	25	D8785	24
C2007	22	C6789	26	C8060	13	D8590	25	D8786	24
C2008	22	C6790	26	C8062	12	D8591	25	D8787	24
C2015	22	C6791	26	C8065	13	C8701	11	D8788	24
C2016	22	C6792	26	C8070	21	C8703	14	D8789	24
C2017	22	C6793	26	C8073	13	C8704	14	D8790	24
C2018	17	C6794	26	C8075	13	C8705	14	D8791	24
C2073	6	C6795	26	C8080	13	C8706	14	D8792	24
C3730	26	C6796	26	D8090	14	C8710	8-9	D8793	24
C3731	26	C6797	26	C8101	5	C8711	8-9	D8794	24
C3732	26	C6798	26	C8102	5	C8712	8-9	D8795	24
C3733	26	C7001	23	C8103	5	C8713	8-9	D8796	24
C3734	26	C7002	23	C8106	5	C8714	8-9	C8797	21
C3735	26	C7003	23	C8108	5	C8715	8-9	C8798	21
C3736	26	C7004	23	C8109	5	C8716	8-9	D8798	24
C3737	26	C7005	23	C8131	6	C8717	8-9	D8799	25
C3738	26	C7006	23	C8133	6	C8718	8-9	C8803	14
C3740	26	C7007	23	C8135	6	C8719	8-9	C8804	14
C3741	26	C7008	23	C8137	10	C8720	8-9	C8826	19
C3742	26	C7009	23	C8139	6	C8721	8-9	C8830	16
C3743	26	C7010	23	C8140	10	C8722	8-9	C8832	16
C3744	26	C7011	23	C8142	10	C8723	8-9	C8834	16
C3745	26	C7012	23	C8143	10	C8724	8-9	D8836	16
C3746	26	C7013	23	C8150	10	C8725	8-9	D8838	17
C3747	26	C7014	23	C8154	10	C8726	8-9	D8840	17
C3750	26	C7015	17	C8155	10	C8730	9	C8850	15
C3751	26	C7020	17	C8160	7	C8732	9	D8890	25
C3752	26	C7021	17	C8161	7	C8733	9	C8896	11
C3753	26	C7022	17	C8163	7	C8735	9	D8950	18
C3754	26	C7101	23	C8173	6	C8747	20	D8951	18
C3755	26	C7102	23			C8749	20	D8952	18
C3756	26	C7103	23					D8999	25
C3757	26								

The Family Of...



PO Box 200
Mauldin, SC 29662
Phone: 864-297-6655 Fax: 864-297-9987
compX.com



715 E. Center Street
Grayslake, IL 60030
Phone: 708-456-1100 Fax: 708-456-9476
compX.com



715 E. Center Street
Grayslake, IL 60030
Phone: 847-234-1864 Fax: 847-234-7922
compX.com



PO Box 200
Mauldin, SC 29662
Phone: 864-297-6655 Fax: 864-297-9987
compX.com

pin tumbler cylinder cam locks

CAM DIMENSIONS

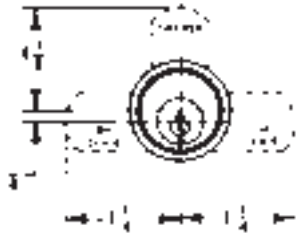

Through the use of a shifter, the 360° key turn turns the cam 90° in either direction. Actual application determines which cam position is the locked position. Each lock is furnished with an alternate cam for opposite cam turn.

Applications: solid lines show locked position of cam	Position of shifter on back of lock	Applications: solid lines show locked position of cam	Position of shifter on back of lock

BRASS CONSTRUCTION



OVERLAY

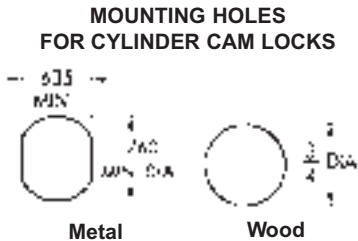

FLUSH



LIPPED/
OVERLAY



C8102

The C8102, as shown above in both pictures, is a Multi-Functional Pin Tumbler Cam Lock with a 1-1/16" Cylinder Length. The lock is packaged with four (4) cams, two straight and two double formed. This allows the lock to be used for multiple applications for either drawer or right hand/left hand doors with lipped or overlay construction.



LIPPED/
OVERLAY

C8101
C8103
C8109



APPLICATION – For drawer, R.H. or L.H. doors. C8103 and C8109 are for lipped or overlay construction. For overlay application, the combined thickness of front and frame cannot exceed the cylinder length. Also see overlay detail below. The other locks are for flush application.

OPERATION – 90° cam turn, key removable in both locked and unlocked positions.

KEYING – Will key together with all other pin tumbler locks using D4291 key blank except locks shown on pages 8 and 9. See table for available keying. Master keying to GM1.

PACKAGING – Supplied with two keys, trim washer, spur washer for wood, mounting nut and two cams. If flat washer (for metal) is needed, order C2015-2C separately. See page 22.



FLUSH

C8106
C8108



OVERLAY

Specific cams to be used with C8102 lock are available for overlay construction using a 3/4" thick front and 3/4" thick frame. See page 23 for details.

Part No.	Type of Mounting	Cylinder Length	Maximum Material Thickness	KA* Codes	Key Changes		Case Quantity	Reference Number	Key Blank
					KD	MKKD			
C8101-26D	Lipped/ Overlay	15/16"	5/8"	4	850	650	10	M2-0106B	D4291
C8101-4		15/16"	5/8"	2	850		10	M2-0106B	D4291
C8102-26D	Flush	1-1/16"	3/4"	4	850	650	10	M2-0106DF	D4291
C8102-4	Flush	1-1/16"	3/4"	2	850		10	M2-0106DF	D4291
C8103-26D	Lipped/ Overlay	1-3/16"	7/8"	4	850	650	10	M2-0106L	D4291
C8103-4		1-3/16"	7/8"	2	850		10	M2-0106L	D4291
C8106-26D	Flush	1-7/16"	1-1/8"	4	850	650	10	M2-0106MF	D4291
C8106-4	Flush	1-7/16"	1-1/8"	2	850		10	M2-0106MF	D4291
C8108-26D	Flush	1-3/4"	1-3/8"	4	850	650	10	M2-0106NF	D4291
C8108-4	Flush	1-3/4"	1-3/8"	2	850		10	M2-0106NF	D4291
C8109-26D	Lipped/ Overlay	1-3/4"	1-1/2"	4	850	650	10	M2-0106N	D4291
C8109-4		1-3/4"	1-1/2"	2	850		10	M2-0106N	D4291

*Key Codes used: 2 Codes – 107 and 915.
4 Codes – 101, 103, 107 and 915.

pin tumbler door & drawer locks

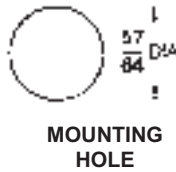

MOUNTING HOLE

C8177, C8178, C8179

APPLICATION – For drawers, R.H. or L.H. doors. Surface mounted. Requires 57/64" dia. hole for cylinder.

OPERATION – Key removable in both locked and unlocked positions.

KEYING – Will key together with all other pin tumbler locks using D4291 key blank except locks shown on pages 8 and 9. See table for available keying. Master keying to GM1.

PACKAGING – Supplied with two keys, strike and mounting screws. If trim ring is required, order C2017 separately. See page 22.

"THE ADVANTAGE PLUS"

To see a video of Advantage PLUS+ visit CompX online: compX.com/advplus

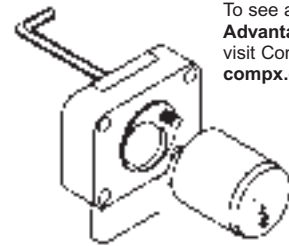

C8173, C8174, C8175

The PLUS feature allows you to remove the cylinder from our pin tumbler box locks while the lock remains in place. No mounting screws need to be removed. Simply use a 5/64" allen wrench from the back to remove the cylinder and plug for re-keying.

Part No.	Installation	Bolt Type	Cylinder Length	Bolt Travel	KA* Codes	Key Changes		Case Quantity	Reference Number	Key Blank
						KD	MKKD			
C8173-26D	Door	Dead	7/8"	3/4"	4	850	650	10	M2-3713-301	D4291
C8173-4	Door	Dead	7/8"	3/4"	2	850	650	10	M2-3713-301	D4291
C8173-4G	Door	Dead	7/8"	3/4"	2	850	—	10	M2-3713-301	D4291
C8174-26D	Door	Dead	1-1/8"	3/4"	4	850	650	10	M2-3713-311	D4291
C8175-26D	Door	Dead	1-3/8"	3/4"	4	850	650	10	M2-3713-321	D4291
C8178-26D	Drawer	Dead	7/8"	3/4"	4	850	650	10	M2-3718-301	D4291
C8178-4	Drawer	Dead	7/8"	3/4"	2	850	—	10	M2-3718-301	D4291
C8178-4G	Drawer	Dead	7/8"	3/4"	2	850	—	10	M2-3718-301	D4291
C8177-26D	Drawer	Dead	1-1/8"	3/4"	4	850	—	10	M2-3718-311	D4291
C8179-26D	Drawer	Dead	1-3/8"	3/4"	4	850	650	10	M2-3718-321	D4291
C8179-4	Drawer	Dead	1-3/8"	3/4"	2	850	—	10	M2-3718-321	D4291



C2073

1/8" black plastic spacer for pin tumbler door and drawer locks. Packed 25 pcs. per bag.



C8133, C8135



MOUNTING HOLE
Additional mortise required for mounting.



C8131



C8139



APPLICATION – For drawers. Half mortise type requires mortise for housing and 57/64" dia. hole for cylinder. C8139 is surface mounted.

OPERATION – Key removable in both locked and unlocked positions except C8131 and C8139.

KEYING – Will key together with all other pin tumbler locks using D4291 key blank except locks shown on pages 8 and 9. See table for available keying. Master keying to GM1.

PACKAGING – Supplied with two keys, strike and mounting screws. If trim ring is required, order C2017 separately. See page 22.

Part No.	Installation	Bolt Type	Cylinder Length	Bolt Travel	KA* Codes	Key Changes		Case Quantity	Reference Number	Key Blank
						KD	MKKD			
C8131-26D**	Drawer	Spring	7/8"	7/32"	4	850	650	10	M2-3701-121	D4291
C8131-4**	Drawer	Spring	7/8"	7/32"	2	850	—	10	M2-3701-121	D4291
C8133-26D	Drawer	Dead	7/8"	1/4"	4	850	—	10	M2-3700-111	D4291
C8133-4	Drawer	Dead	7/8"	1/4"	2	850	—	10	M2-3700-111	D4291
C8135-26D	Drawer	Dead	1-1/8"	1/4"	4	850	—	10	M2-3700-159	D4291
C8139-26D**	Door	Spring	3/4"	7/32"	4	850	650	10	M2-3719-092	D4291

*Key Codes used: 2 Codes – 107 and 915.

4 Codes – 101, 103, 107 and 915.

**Key removable in locked position only.

pin tumbler drawer locks

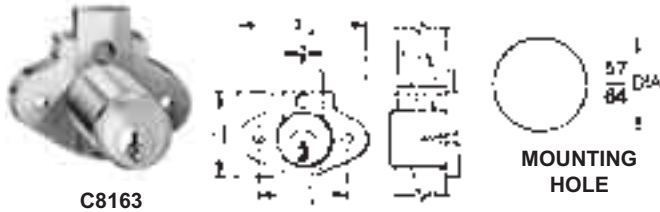

APPLICATION – For drawers. Surface mounted. Requires 57/64” dia. hole for cylinder.

OPERATION – Key removable in both locked and unlocked positions.

KEYING – Will key together with all other pin tumbler locks using D4291 key blank except locks shown on pages 8 and 9. See table for available keying. Master keying to GM1.

PACKAGING – Supplied with two keys and mounting screws. If trim ring is required, order C2017 separately. See page 22.

“THE ADVANTAGE PLUS”



C8163 locks feature easy removal of cylinder from lock housing while lock remains in place. Bolt has access hole for cylinder retention screw at back of lock. U.S. Patent No. 4,899,563.



C7163-2C

Extended bolt for C8163 drawer lock provides 3” extension, can be cut to required length. Packed 20 pcs. per bag.

Part No.	Installation	Bolt Type	Cylinder Length	Bolt Travel	KA* Codes	Key Changes		Case Quantity	Reference Number	Key Blank
						KD	MKKD			
C8163-26D	Drawer	Dead	15/16”	11/32”	4	850	650	10	M2-3705	D4291
C8163-4	Drawer	Dead	15/16”	11/32”	4	850	650	10	M2-3705	D4291

pin tumbler door & drawer locks

“THE ADVANTAGE PLUS” CAM LOCKS

The locks are fastened in place with two screws for easy installation. Re-keying or servicing is accomplished by removing the cam retaining screw and cam. Use a 5/64” allen wrench to remove the plug cylinder assembly. The mounting plate remains installed on the cabinet. Re-key as required and reinstall cylinder plug assembly on mounting plate.

U.S. PATENT NO. 5,678,438

ONE LOCK, TWO FUNCTIONS
DOOR OR DRAWER



C8183
Assembled as a
Door Lock



C8188
Assembled as
a Drawer Lock



APPLICATION – For drawer, R.H. or L.H. doors. C8183 assembled for door function. C8188 assembled for drawer function.

OPERATION – 90° cam turn, key removable in both locked and unlocked positions.

KEYING – Will key together with all other pin tumbler locks

using D4291 key blank except locks shown on pages 8 and 9. See table for available keying. Master keying to GM1.

PACKAGING – Supplied with two keys, extra backplate, two cams and two mounting screws. If trim ring is required, order C2017 separately. See page 22. **Note:** If formed cam is required, order C7113 or C7116. See page 23.

Part No.	Type of Mounting	Cylinder Length	Maximum Material Thickness	KA* Codes	Key Changes		Case Quantity	Reference Number	Key Blank
					KD	MKKD			
C8183-26D	Flush	7/8”	7/8”	4	850	650	10	M2-8183	D4291
C8188-26D		1-3/8”	1-3/8”	4	850	650	10	M2-8188	D4291

*Key Codes used: 4 Codes – 101, 103, 107 and 915.

pin tumbler drawer lock

APPLICATION – Replacement lock housing and cylinder for drawers with 7/8” thick fronts. Half mortise design.

OPERATION – Key removable in both locked and unlocked positions. Interchangeable cylinders are attached or removed through the use of a special key at back of lock.

KEYING – Keyed differently (100 changes).

PACKAGING – C8160 cylinder supplied with two keys. C8161 lock housing supplied with cylinder removal key and mounting screws.

CYLINDER REMOVAL KEY



C8161

C8160



Part No.	Type of Mounting or Installation	Bolt Type	Minimum Material Thickness	Bolt Travel	Key changes KD	Case Quantity	Reference Number	Key Blank
C8160-26D	In Housing	—	—	—	100	10	M2-3720-025	D4292
C8161-26	Drawer	Dead	7/8”	9/32”	—	10	M3-3720-011	—

pin tumbler mail box locks

GENUINE FACTORY REPLACEMENT LOCKS

APPLICATION – For doors on architectural mail boxes serviced by United States Postal Service.

OPERATION – 90° cam turn. See drawing for specific operation. Key removal in locked position only.

KEYING – Available keyed differently only (100 changes).

PACKAGING – Supplied with two keys and a spring mounting clip. C8720 furnished with trim ring.

*C8712 and C8720 are provided with a threaded cylinder, with proper clip grooving.

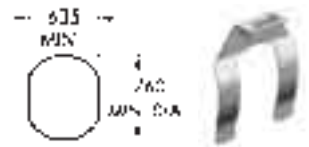

MOUNTING HOLE FOR ALL LOCKS

SPRING MOUNTING CLIP

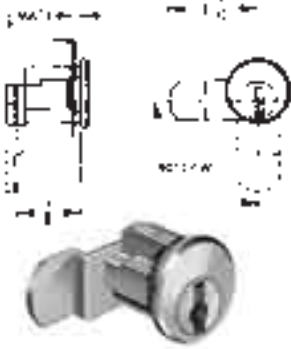

C8710

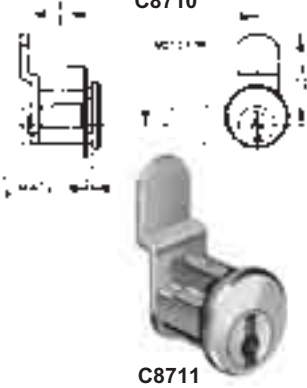

C8711

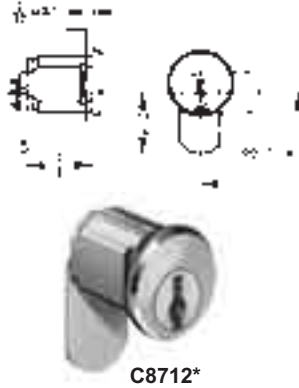

C8712*

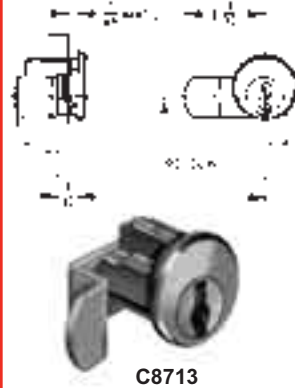

C8713

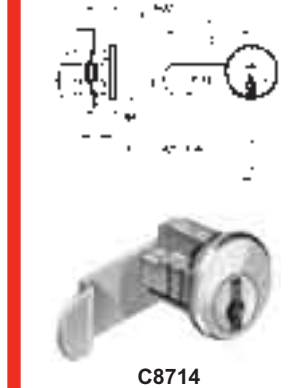

C8714

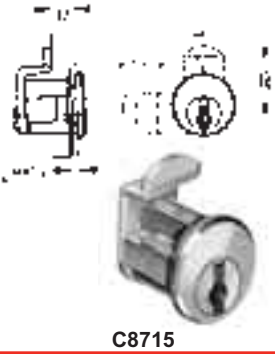

C8715

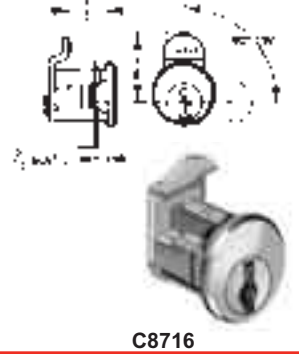

C8716

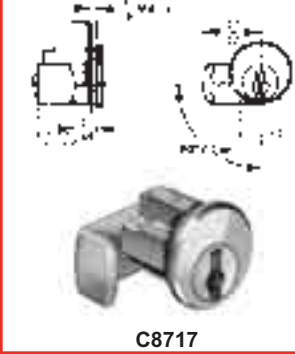

C8717

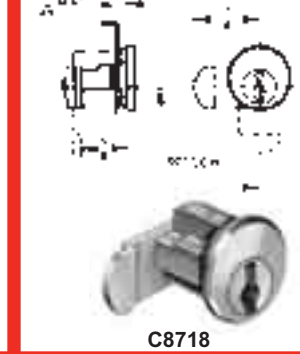

C8718

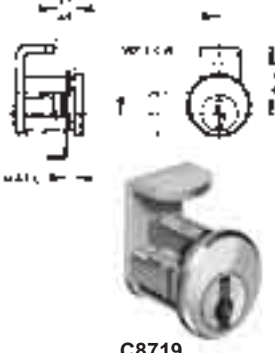

C8719

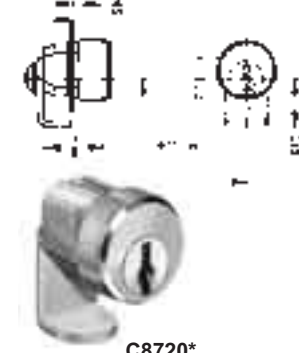

C8720*

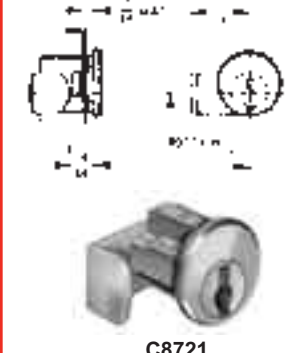

C8721



C8722

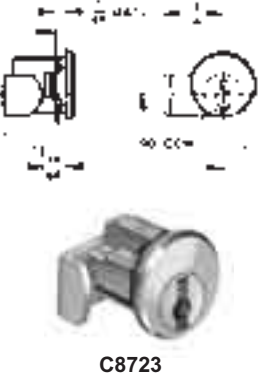

C8723

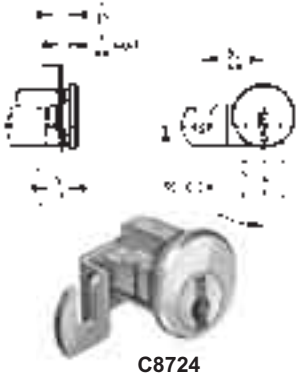

C8724

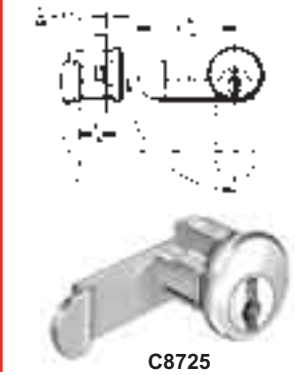

C8725



C8726

pin tumbler mail box locks

Part No.	Locked Cam Position	Direction of Turn to Open	Replaces	Key Changes KD	Case Quantity	Key Blank
C8710	Left	90° c/cw	Bommer Industries	100	25	D4291
C8711	Up	90° c/cw	Bommer Industries	100	25	D4291
C8712	Down	90° c/cw	Bommer Industries	100	25	D4291
C8713	Left	90° c/cw	Auth Electric — Also replaces Bommer Lock B25-300 used on Bommer Box No. 9015 (sleeve inside box must be removed)	100	25	D4291
C8714	Left	90° c/cw	American Device	100	25	D4291
C8715	Up	90° c/cw	Florence Mfg.	100	25	D4291
C8716	Up	90° cw	S.H. Couch	100	25	D4291
C8717	Left	90° c/cw	Nutone	100	25	D4291
C8718	Left	90° c/cw	Cutler Mail Chute	100	25	D4291
C8719	Up	90° c/cw	Miami-Carey	100	25	D4291
C8720	Down	90° cw	Dura Steel	100	25	D4291
C8721	Left	90° c/cw	Permabit — XL-201	100	25	D4291
C8722	Down	90° cw	Dura Steel — XL-202	100	25	D4291
C8723	Left	90° c/cw	Jensen General	100	25	D4291
C8724	Left	90° c/cw	Bommer Industries	100	25	D4291
C8725	Left	90° c/cw	Cutler Federal	100	25	D4291
C8726	Right	90° cw	Riopel — Canada	100	25	D4291

pin tumbler “multi-cam”™ mail box locks

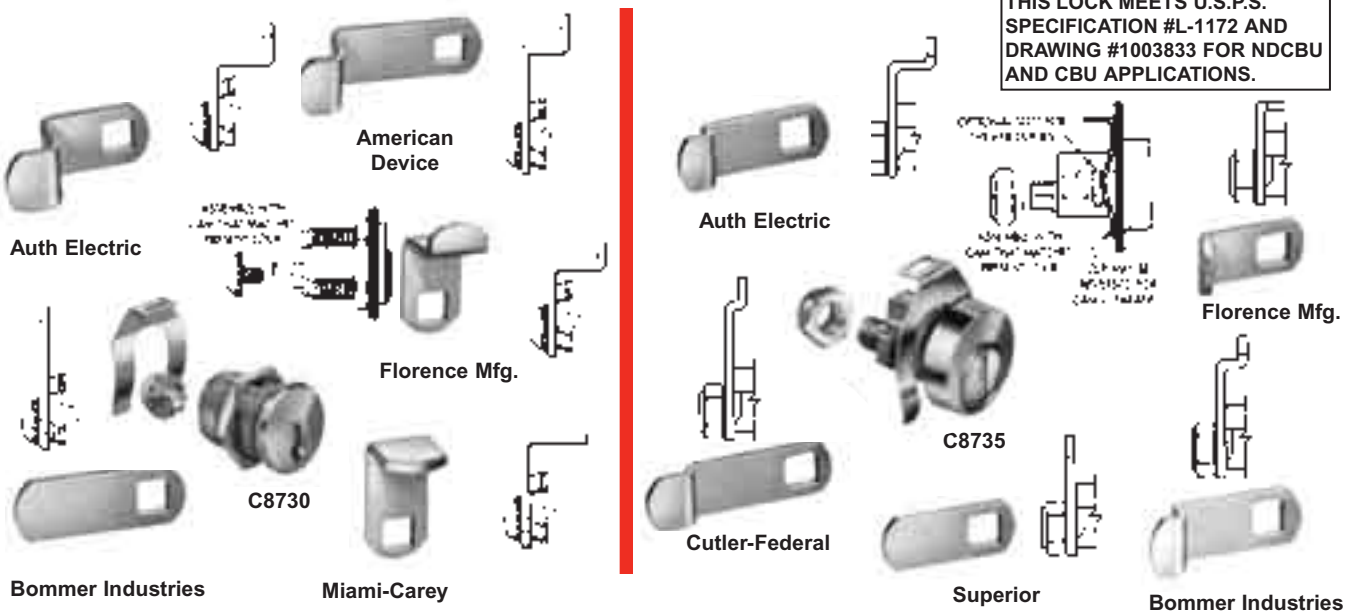

THIS LOCK MEETS U.S.P.S. SPECIFICATION #L-1172 AND DRAWING #1003833 FOR NDCBU AND CBU APPLICATIONS.

“MULTI-PURPOSE”

APPLICATION – Interior architectural mail boxes used in apartments, condominiums, schools, lobbies. **Nut or clip mounted.**

OPERATION – 90° counter-clockwise cam turn to open. Key removable in locked position.

KEYING – Available keyed differently only (100 changes).

PACKAGING – Supplied with selection of five cams, two keys, **mounting nut, mounting clip** and cam screw.

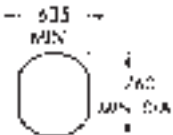

MOUNTING HOLE FOR ALL LOCKS

APPLICATION – Exterior pedestal-mounted neighborhood boxes. Has keyway dust shutter for lock protection. **Clip mounted.**

OPERATION – 90° clockwise cam turn to open. Key removable in locked position.

KEYING – Available keyed differently only (100 changes).

PACKAGING – Supplied with a selection of five cams, three keys, mounting clip, cam locking nut.

Part No.	Installation	Direction of Turn to Open	Key Changes KD	Case Quantity	Key Blank
C8730	Architectural mail box fronts	90° c/cw	100	25	D4291
C8732	Same as C8735 w/o cams	90° cw	100	25	D4291
C8733	Same as C8735 w/o cams	90° c/cw	100	25	D4291
C8735	Door of pedestal mounted neighborhood boxes	90° cw	100	25	D4291

pin tumbler drawer locks



C8137

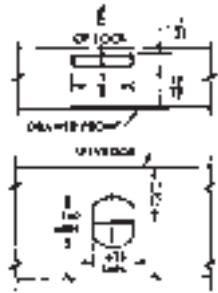

MOUNTING HOLES

APPLICATION – For center drawers of metal desks. Fits special piercing of drawer front and seldge (see drawing).

OPERATION – Key removable in both locked and unlocked positions.

KEYING – Will key together with all other pin tumbler locks using D4291 key blank except locks shown on pages 8 & 9. See table for available keying. Master keying to GM1.

PACKAGING – Supplied with two keys and mounting nut.

Part No.	Installation	Bolt Type	Cylinder Length	Bolt Travel	KA* Codes	Key Changes		Case Quantity	Reference Number	Key Blank
						KD	MKKD			
C8137-26D	Metal Drawer, 1/4" Max Mat'l Thickness	Reinforced Insertable Dead Bolt	19/32"	7/16"	4	850	650	10	M2-3727-001	D4291

*Key Codes used: 4 Codes – 101, 103, 107 and 915.

pin tumbler sliding door, file cabinet locks

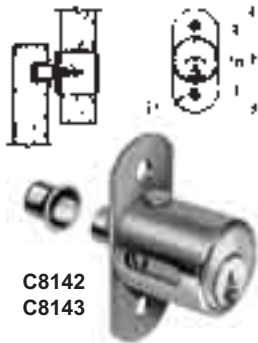

C8142
C8143

APPLICATION – C8140 is for sliding glass doors. C8142 and C8143 are for wood sliding doors and require a 7/8" dia. hole in front door for cylinder. C8150 is used internally on filing cabinets to gang lock drawers.

OPERATION – C8140 and C8150: key removable in locked position only. C8142 and C8143: key removable in both locked and unlocked positions.

KEYING – Will key together with all other pin tumbler locks using D4291 key blank except locks shown on pages 8 & 9. See table for available keying. Master keying to GM1.

PACKAGING – Supplied with two keys. C8142 and C8143 furnished with strike and mounting screws. If trim ring is required, order C2017 separately. See page 22.

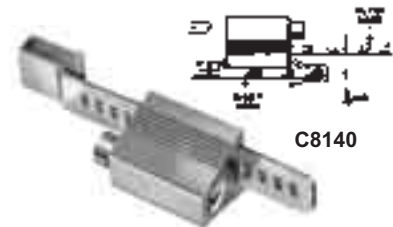

C8140

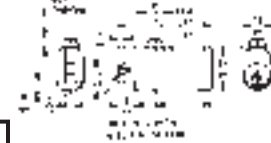

C8150

Part No.	Installation	Bolt Type	Cylinder Length	Bolt Travel	KA* Codes	Key Changes		Case Quantity	Reference Number	Key Blank
						KD	MKKD			
C8140-26D	Plate Glass Sliding Doors	Internal Spring	—	—	4	100	—	10	M2-0225-001	D4291
C8142-26D	Sliding Doors	Plunger	1-1/8"	7/16"	6	100	100	10	M2-3707-157	D4291
C8142-4	Sliding Doors	Plunger	1-1/8"	7/16"	2	100	—	10	M2-3707-157	D4291
C8143-26D	Sliding Doors	Plunger	1-3/8"	7/16"	4	100	—	10	M2-3707-160	D4291
C8143-4	Sliding Doors	Plunger	1-3/8"	7/16"	2	100	—	10	M2-3707-160	D4291
C8150-26D	Filing Cabinet	Spring	—	1/8"	5	850	—	10	M2-4847-001	D4291

*Key Codes used: 2 Codes – 107 and 915.

4 Codes – 101, 103, 107 and 915.

5 Codes – 101, 102, 103, 107 and 915.

6 Codes – 101, 103, 105, 106, 107 and 915.

pin tumbler knob locks



C8154, C8155

APPLICATION – For metal cabinets doors. Reversible for R.H. or L.H. application. Latch plate is used for either in 2** or 3 point latching.

OPERATION – 90° turn to open. Choice of key operation, see table.

KEYING – Will key together with all other pin tumbler locks using D4291 key blank except locks shown on pages 8 & 9. See table for available keying. Master keying to GM1.

PACKAGING – Supplied with two keys, mounting nut and screw for latch plate.

**Install with tongue pointing away from jamb.

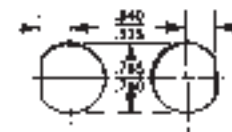

L.H. Door R.H. Door

MOUNTING HOLES

Part No.	Installation	Operation of Key	Maximum Material Thickness	KA* Codes	Key Changes KD	Case Quantity	Reference Number	Key Blank
C8154-26D	Door	Key Removable in Both Locked and Unlocked Positions	1/8"	3	650	10	M2-0721-010 w/M3-6921	D4291
C8155-26D	Door	Key Removable in Locked Position Only	1/8"	1	650	10	M2-0721-060 w/M3-6921	D4291

*Key Codes used: 1 Code – 915.

3 Codes – 103, 107 and 915.

disc tumbler drawer locks



C8701

MOUNTING HOLES

APPLICATION – C8701: for center drawers of metal desks. Fits special piercing of drawer front and sledge (see drawing). C8896 is a specific replacement lock.
OPERATION – Key removable in both locked and unlocked positions.
KEYING – C8701 will key together with all other disc tumbler locks using D8785 key blank. See table for available keying. Master keying to E41A using D8783 key blank.
PACKAGING – Supplied with two keys. C8701 furnished with mounting nut.

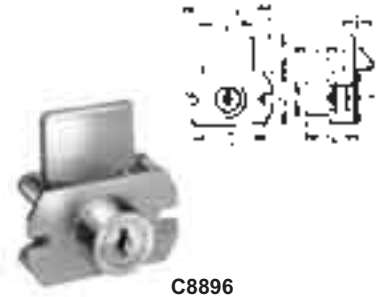

C8896

Part No.	Installation	Bolt Type	Cylinder Length	Bolt Travel	KA* Codes	Key Changes		Case Quantity	Reference Number	Non MK Key Blank
						KD	MKKD			
C8701-14A	Metal Drawer, 1/4" max. mat'l. thickness	Reinforced Insertable Dead Bolt	19/32"	11/32"	6	200	200	25	M4-0344-001	D8785
C8896-26D	Desk Drawer	Dead	1/2"	5/8"	1	50	—	10	M4-5596-001	D8785

disc tumbler sliding door locks

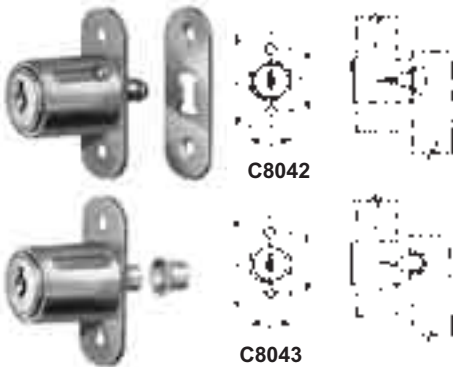

C8042

C8043

APPLICATION – For wood sliding doors. Requires a 7/8" dia. hole in front door for cylinder.
OPERATION – C8042: push in cylinder, key turn engages bolt behind strike. C8043: pushing in cylinder locks doors. Key removable in both locked and unlocked positions.
KEYING – Will key together with all other disc tumbler locks using D8785 key blank. See table for keying. Master keying to E41A using D8783 key blank.
PACKAGING – Supplied with two keys, strike and mounting screws. If trim ring is required, order C2017 separately. See page 22.



MOUNTING HOLE

Part No.	Installation	Bolt Type	Cylinder Length	Bolt Travel	KA* Codes	Key Changes		Case Quantity	Reference Number	Non MK Key Blank
						KD	MKKD			
C8042-26D	Sliding Doors	90° Turn Hook	7/8"	7/16"	3	200	—	10	M4-0057-001	D8785
C8043-26D	Sliding Doors	Plunger	1"	7/16"	6	200	200	10	M4-0055	D8785
C8043-3	Sliding Doors	Plunger	1"	7/16"	6	200	—	10	M4-0055	D8785
C8043-14A	Sliding Doors	Plunger	1"	7/16"	6	200	—	10	M4-0055	D8785

*Key Codes used: 1 Code – C415A.
 3 Codes – C346A, C413A and C415A.
 6 Codes – C346A, C390A, C413A, C415A, C420A and C642A.

disc tumbler file cabinet locks



C8046

APPLICATION – Used internally on filing cabinets to gang lock drawers.
OPERATION – Key removable in locked position only.
KEYING – Keyed only to "Pundra" keyway. See table for available keying.
PACKAGING – Supplied with two keys.



REPLACEMENT FOR "SHAW WALKER"



C8047

Part No.	Installation	Bolt Type	Bolt Travel	KA* Codes	Key Changes		Case Quantity	Reference Number	Key Blank
					KD	MKKD			
C8046-26	Filing Cabinet	Spring	1/8"	1	200	—	10	P4-3003	D8776
C8047-26	Filing Cabinet	Spring	1/8"	1	200	—	10	P4-3012	D8776

*Key Codes used: 1 Code – P141A.

disc tumbler cylinder cam locks

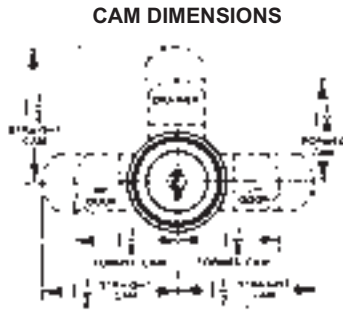
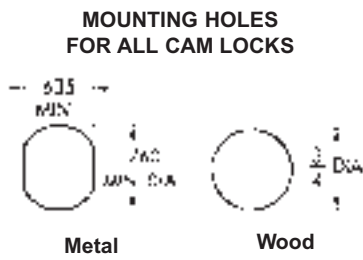

LOCK APPLICATION

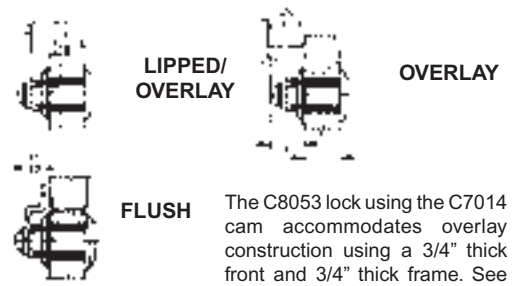

The C8053 lock using the C7014 cam accommodates overlay construction using a 3/4" thick front and 3/4" thick frame. See page 23 for details.



Locks furnished with straight cams assembled

APPLICATION – For drawers, R.H. or L.H. doors with lipped/overlay construction (straight cam) or flush construction (formed cam). For overlay application, the combined thickness of front and frame cannot exceed the cylinder length. Also see overlay detail at above right.

OPERATION – 90° cam turn on all locks. Key removable in both locked and unlocked positions.

KEYING – Will key together with all other disc tumbler locks using D8785 key blank. See table for available keying. Master keying to E41A using D8783 key blank.

PACKAGING – Supplied with two keys, trim washer, spur washer (for wood), mounting nut and two cams. If flat washer (for metal) is needed, order C2015-2C separately. See page 22.

Part No.	Type of Mounting	Cylinder Length	Maximum Material Thickness	KA* Codes	Key Changes		Case Quantity	Reference Number	Non MK Key Blank
					KD	MKKD			
C8051-14A	Lipped/Overlay or Flush	7/16"	7/64"	6	200	200	25	M4-0553	D8785
C8051-3		7/16"	7/64"	3	200	—	25	M4-0553	D8785
C8052-14A		5/8"	15/64"	6	200	200	25	M4-0054	D8785
C8052-3		5/8"	15/64"	3	200	—	25	M4-0054	D8785
C8054-14A		15/16"	5/8"	6	200	200	25	M4-0054B	D8785
C8054-3		15/16"	5/8"	3	200	—	25	M4-0054B	D8785
C8054-4G		15/16"	5/8"	3	200	—	25	M4-0054B	D8785
C8053-14A		1-3/16"	7/8"	6	200	200	25	M4-0054C	D8785
C8053-3		1-3/16"	7/8"	6	200	200	25	M4-0054C	D8785
C8053-4G		1-3/16"	7/8"	6	200	200	25	M4-0054C	D8785
C8055-14A		1-7/16"	1-1/8"	6	200	200	25	M4-0054L	D8785
C8055-3		1-7/16"	1-1/8"	6	200	200	25	M4-0054L	D8785
C8055-4G		1-7/16"	1-1/8"	6	200	200	25	M4-0054L	D8785

*Key Codes used: 3 Codes – C346A, C413A and C415A.
6 Codes – C346A, C390A, C413A, C415A, C420A and C642A.

disc tumbler reversible key cam locks

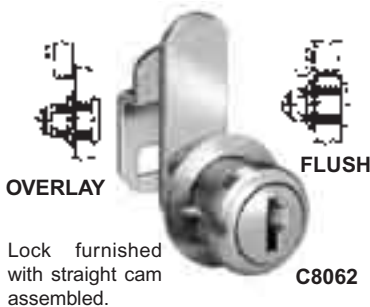

APPLICATION – For drawers, R.H. or L.H. doors with overlay (straight cam) or flush (formed cam) construction. For overlay application, the combined thickness of front and frame cannot exceed the 7/8" cylinder length. See above for mounting hole detail.

OPERATION – 90° cam turn. Key removable in both locked and unlocked positions.

KEYING – Reversible key operation. Keyed to SK Series; does not key with other disc tumbler locks in this catalog. See table for available keying.

PACKAGING – Supplied with two keys, spur washer (for wood), mounting nut and two cams. If flat washer (for metal) is needed, order C2015-2C separately. See page 22.



Part No.	Type of Mounting	Cylinder Length	Maximum Material Thickness	KA* Codes	Key Changes KD	Case Quantity	Reference Number	Key Blank
C8062-14A	Overlay or Flush	7/8"	9/16"	1 SK1	100	25	M4-0300	D8777

disc tumbler cylinder cam locks

MOUNTING HOLES FOR CYLINDER CAM LOCKS

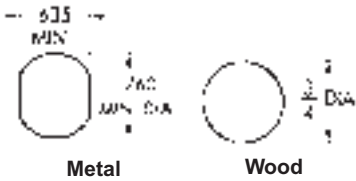

Metal

Wood

with flexafunction™
180° 90°



C8060, C8073, C8075
Assembled with straight cam and 90° cam rotation.

CAM DIMENSIONS

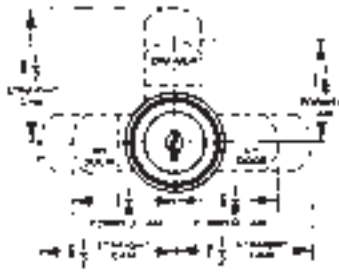

LOCK APPLICATION

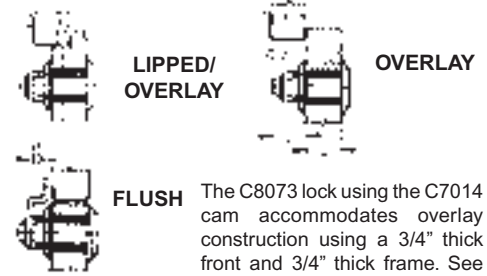

LIPPED/OVERLAY

OVERLAY

FLUSH

The C8073 lock using the C7014 cam accommodates overlay construction using a 3/4" thick front and 3/4" thick frame. See page 23 for details.

All locks feature flexafunction™
Stop washers provide for either 180° or 90° cam turn.



C8080

with flexafunction™
90° 180°

APPLICATION – For drawers, R.H. or L.H. doors with lipped/overlay construction (straight cam) or flush construction (formed cam). For overlay application, the combined thickness of front and frame cannot exceed the cylinder length. Also see overlay detail at above right.

OPERATION – Choice of either 90° or 180° cam turn. Key removable in both locked and unlocked positions.

KEYING – Will key together with all other disc tumbler locks using D8785 key blank. See table for available keying. Master keying to E41A using D8783 key blank.

PACKAGING – Supplied with two keys, trim washer, spur washer (for wood), mounting nut, two cams and two stop washers. If flat washer (for metal) is needed, order C2015-2C separately. See pg. 22.

APPLICATION – For doors and drawers. Surface mounted. Requires 3/4" dia. hole for cylinder

OPERATION – Choice of either 90° or 180° cam turn. Key removable in both locked and unlocked positions.

KEYING – Will key together with all other disc tumbler locks using D8785 key blank. See table for available keying. Master keying to E41A using D8783 key blank.

PACKAGING – Supplied with two keys, two mounting screws, two formed cams and two stop washers. Assembled for 90° cam turn.

Part No.	Type of Mounting	Cylinder Length	Maximum Material Thickness	KA* Codes	Key Changes		Case Quantity	Reference Number	Non MK Key Blank
					KD	MKKD			
C8060-14A	Lipped/Overlay or Flush	1-3/4"	1-7/16"	6	200	200	25	M4-8060	D8785
C8060-3		1-3/4"	1-7/16"	6	200	200	25	M4-8060	D8785
C8060-4G		1-3/4"	1-7/16"	6	200	200	25	M4-8060	D8785
C8073-14A		1-3/16"	7/8"	6	200	200	25	M4-8073	D8785
C8073-3		1-3/16"	7/8"	6	200	200	25	M4-8073	D8785
C8073-4G		1-3/16"	7/8"	6	200	200	25	M4-8073	D8785
C8075-14A		1-7/16"	1-1/8"	6	200	200	25	M4-8075	D8785
C8075-3		1-7/16"	1-1/8"	6	200	200	25	M4-8075	D8785
C8075-4G		1-7/16"	1-1/8"	6	200	200	25	M4-8075	D8785
C8080-14A		7/8"	7/8"	6	200	200	25	M4-8080	D8785
C8080-3		7/8"	7/8"	6	200	200	25	M4-8080	D8785
C8080-4G		7/8"	7/8"	6	200	200	25	M4-8080	D8785

*Key Codes used: 6 Codes – C346A, C390A, C413A, C415A, C420A and C642A.

screwdriver cam latch



C8065



90° 180°
with flexafunction™

APPLICATION – For drawers or doors that do not require a key for locking.

OPERATION – flexafunction™ feature provides choice of 90° or 180° cam turn. Cams are double punched for flexibility in mounting latch.

PACKAGING – Supplied with two cams, two stop washers, spur washer and mounting nut.

Part No.	Type of Mounting	Cylinder Length	Maximum Material Thickness	Case Quantity	Reference Number
C8065-14A	Lipped, Overlay or Flush	5/8"	1/4"	25	M6-4540

disc tumbler door & drawer locks



C8703, C8705



C8803



*C8804

* This item will be discontinued when inventory is depleted.



C8706



C8704



APPLICATION – For drawers and doors. Surface mounted. Requires 7/8" dia. hole for cylinder.

OPERATION – Key removable in both locked and unlocked positions except C8706.

KEYING – Will key together with all other disc tumbler locks using D8785 key blank. See table for available keying. Master keying to E41A using D8783 key blank.

PACKAGING – Supplied with two keys and mounting screws. C8706 furnished with strike. If trim ring is required, order C2017 separately. See page 22.

Part No.	Installation	Bolt Type	Cylinder Length	Bolt Travel	KA* Codes	Key Changes		Case Quantity	Reference Number	Non MK Key Blank
						KD	MKKD			
C8703-14A	Drawer	Dead	15/16"	11/32"	6	200	200	25	M4-6707-170	D8785
C8703-3	Drawer	Dead	15/16"	11/32"	6	200	200	25	M4-6707-170	D8785
C8703-4G	Drawer	Dead	15/16"	11/32"	6	200	200	25	M4-6707-170	D8785
C8704-14A	Door	Dead	15/16"	11/32"	6	200	200	25	M4-6707-172	D8785
C8704-3	Door	Dead	15/16"	11/32"	6	200	200	25	M4-6707-172	D8785
C8704-4G	Door	Dead	15/16"	11/32"	6	200	200	25	M4-6707-172	D8785
C8705-14A	Drawer	Dead	1-3/16"	11/32"	3	200	200	25	M4-6707-171	D8785
C8705-3	Drawer	Dead	1-3/16"	11/32"	3	200	200	25	M4-6707-171	D8785
C8705-4G	Drawer	Dead	1-3/16"	11/32"	3	200	—	25	M4-6707-171	D8785
C8706-3	Drawer	Spring	15/16"	9/32"	3	200	—	25	M4-6708-170	D8785
C8803-14A	Drawer	Dead	15/16"	11/32"	6	200	200	25	M4-8803-001	D8785
C8803-3	Drawer	Dead	15/16"	11/32"	6	200	200	25	M4-8803-001	D8785
C8803-4G	Drawer	Dead	15/16"	11/32"	6	200	200	25	M4-8803-001	D8785
C8804-14A	Door	Dead	15/16"	11/32"	6	200	200	25	M4-8804-001	D8785
C8804-3	Door	Dead	15/16"	11/32"	6	200	200	25	M4-8804-001	D8785
C8804-4G	Door	Dead	15/16"	11/32"	6	200	200	25	M4-8804-001	D8785

*Key Codes used: 3 Codes – C346A, C413A and C415A.

6 Codes – C346A, C390A, C413A, C415A, C420A and C642A.

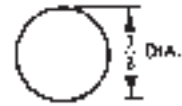

MOUNTING HOLE

disc tumbler gang lock



Cylinder is located near top of pedestal.



Saddle reverses for mortise application.



D8090

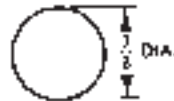

MOUNTING HOLE

Additional 7/8" x 1/8" deep dado for bar required on inside of panel.

APPLICATION – For locking drawers in desk pedestals and other multiple drawer applications. Requires 7/8" dia. hole for cylinder and dado for bar, measuring 7/8" x 1/8" deep on inside of panel.

OPERATION – Key removable in both locked and unlocked positions. Turning the key locks all drawers simultaneously (drawers must be in closed position). Bar moves studs into notch in drawer or slide, thus preventing drawer movement.

KEYING – Will key together with all other disc tumbler locks using D8785 key blank. See table for available keying. Master keying to E41A using D8783 key blank.

PACKAGING – Supplied with two keys, three locking studs, three stud slides, saddle and mounting screws. If trim ring is required, order C2017 separately. See page 22.

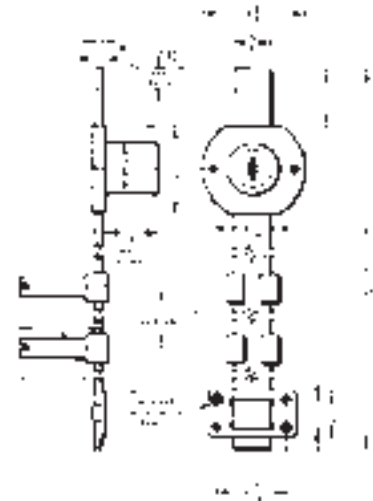

Part No.	Installation	Bar Operation	Cylinder Length	Bar Travel	KA* Codes	Key Changes		Case Quantity	Reference Number	Non MK Key Blank
						KD	MKKD			
D8090-14A	Desk Pedestals or Similar Multi-Drawer Conditions	Dead Locking	15/16"	11/32"	6	200	200	5	M4-6709-124	D8785
D8090-3			15/16"	11/32"	6	200	—	5	M4-6709-124	D8785
D8090-4G			15/16"	11/32"	6	200	—	5	M4-6709-124	D8785

*Key Codes used: 6 Codes – C346A, C390A, C413A, C415A, C420A and C642A.

disc tumbler furniture locks



Now an entire furniture locking system can be changed in a matter of minutes, not days, through flexible key control.

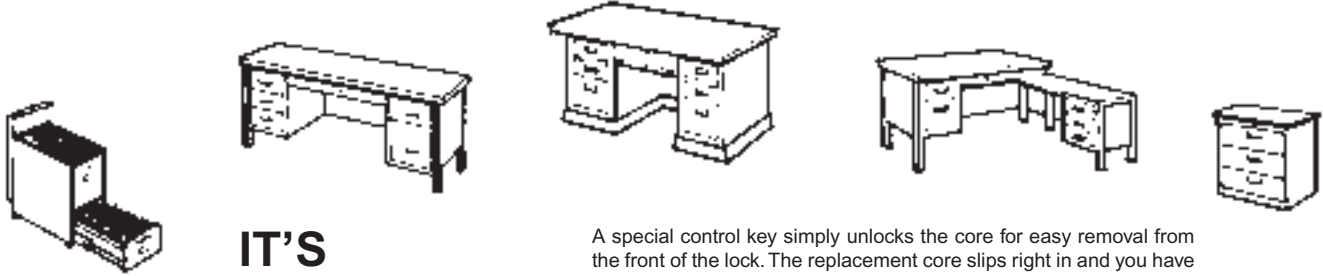

**IT'S
EASY!**

A special control key simply unlocks the core for easy removal from the front of the lock. The replacement core slips right in and you have it, security restored!

Replacement cores are readily available.

D8779
Control Key

SMALL DIAMETER FURNITURE LOCKS

LOCK CORE...

**ONE PLUG
FITS ALL!**

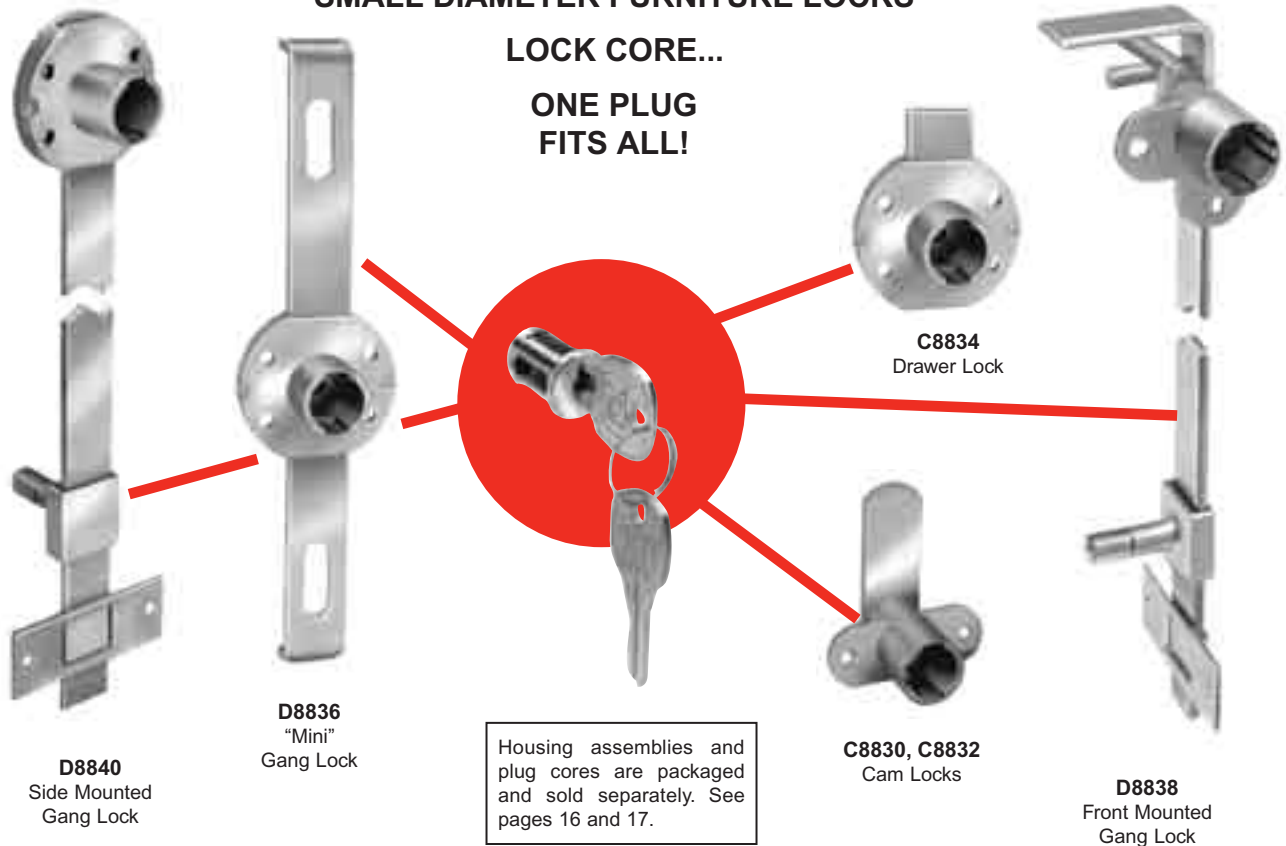

D8840
Side Mounted
Gang Lock

D8836
"Mini"
Gang Lock

C8834
Drawer Lock

C8830, C8832
Cam Locks

D8838
Front Mounted
Gang Lock

Housing assemblies and plug cores are packaged and sold separately. See pages 16 and 17.

plug core for furniture locks



C8850

Part No.	KA* Codes	KD Codes	Case Quantity	Key Blank
C8850-14A	20	200	25	D8783
C8850-3	20	200	25	D8783
C8850-19	20	200	25	D8783

*Key Codes used: D003A, D054A, D071A, D084A, D091A, D177A, D233A, D256A, D284A, D313A, D346A, D362A, D390A, D413A, D415A, D420A, D435A, D512A, D554A and D642A.

APPLICATION – One Plug Fits All for RemovaCore locks on furniture applications.

OPERATION – In all RemovaCore applications, key is removable in both locked and unlocked positions.

KEYING – All Cores are Master keyed to E13A. Will key together with all other disc tumbler locks using D8783 key blank, except C8051 and C8052. See table for available keying. KA to 20 changes, including all six standard disc tumbler codes.

PACKAGING – Supplied with two keys.



THESE LOCKS ALL FEATURE



CAM LOCKS



C8830 (90°) Cam Lock
C8832 (180°) Cam Lock (shown)

Can also be used with pin cams.
See page 17.

Use
C8850
Core



APPLICATION – For wood pedestals, door or drawer, R.H. or L.H. Surface Mounted. For flipper door use C7015 offset cam and C2003 strike. See pages 17 and 22.

OPERATION – Choice of 90° or 180° cam rotation, CCW to lock.

KEYING – Order core plug separately, C8850, see pg. 15.

PACKAGING – Housing assembly supplied with two mounting screws and straight cam. Housings are unplated.

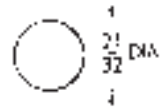

MOUNTING HOLE

Part No.	Description	Type of Installation	Cam Rotation	Lock Cylinder Length	Maximum Material Thickness	Case Quantity
C8830	Housing Assembly	Pedestal	90°	3/4"	3/4"	25
C8832	Housing Assembly	Pedestal	180°	3/4"	3/4"	25

SIDE MOUNTED TWO DRAWER "MINI" GANG LOCK

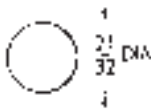

MOUNTING HOLE



D8836 "Mini" Gang Lock



Use
C8850
Core

DRAWER LOCK

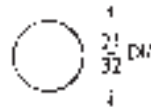

MOUNTING HOLE



C8834 Drawer Lock



Use
C8850
Core

APPLICATION – Two drawer "Mini Gang" lock for desk or pedestals, and single locking drawer for desk or pedestals. Surface Mounted.

OPERATION – Key turn on the D8836 moves the 6" bar from above or below the plastic stops, which are mounted on drawer sides, thus preventing drawer movement. C8834 has a 11/32" bolt throw.

KEYING – Order core plug separately, C8850, see page 15.

PACKAGING – Housing assemblies supplied with four mounting screws and bolt. D8836 comes with two plastic stops and mounting screws. Housings are unplated.

Part No.	Description	Type of Installation	Bar/Bolt Operation	Lock Cylinder Length	Bar/Bolt Travel	Case Quantity
D8834	Housing Assembly	Single Drawer	Dead	3/4"	11/32"	25
D8836	Housing Assembly	Desk Pedestals on two drawer applications	Dead Locking	3/4"	11/32"	10

disc tumbler furniture locks

GANG LOCKS WITH

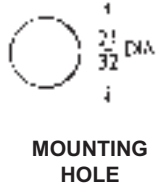

Additional 7/8" x 3/16" dado for bar required on inside of side panel.

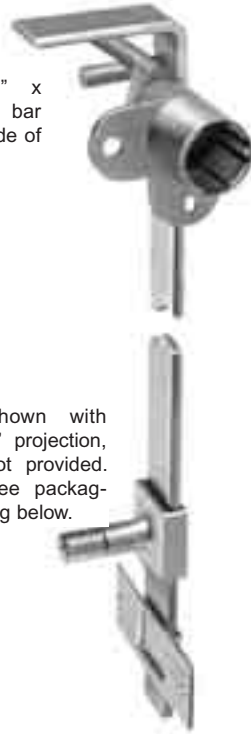

Shown with 1" projection, not provided. See packaging below.

D8838 Front Mounted Gang Lock

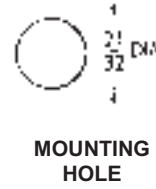

Both Locks Use **C8850** Core



Shown with 1" projection, not provided. See packaging below.

D8840 Side Mounted Gang Lock

APPLICATION – For locking drawers in desk pedestals and other multiple drawer applications. Lock mounts in right corner. Can also be mounted for left corner application. Surface mounted. Requires 21/32" dia. hole for cylinder, and when required, a dado for bar, measuring 7/8" x 3/16" deep in inside of panel.

OPERATION – Turning the key locks all drawers simultaneously (drawers must be in closed position). Bar moves studs from above or below the plastic stops, which are mounted on drawer sides, thus preventing drawer movement.

KEYING – Order core plug separately, C8850, see page 15.

PACKAGING – Housing assembly supplied with three set screws for 1/2" projection, three slides, saddle, three plastic stops, and mounting screws. If 1" projection is required, order locking studs separately.

APPLICATION – For locking drawers in desk pedestals and other multiple drawer applications. Lock mounts on inside of unit. Surface mounted. Requires 21/32" dia. hole for cylinder.

OPERATION – Turning the key locks all drawers simultaneously (drawers must be in closed position). Bar moves studs from above or below the plastic stops, which are mounted on drawer sides, thus preventing drawer movement.

KEYING – Order core plug separately, C8850, see page 15.

PACKAGING – Housing assembly supplied with three set screws for 1/2" projection, three slides, saddle, three plastic stops, and mounting screws. If 1" projection is required, order locking studs separately.

Part No.	Description	Type of Installation	Bar Operation	Lock Cylinder Length	Bar Travel	Case Quantity
D8838	Housing Assembly	Desk Pedestal & Multi-Drawer applications	Dead Locking	3/4"	5/8"	5
D8840	Housing Assembly		Dead Locking	3/4"	11/32"	5

accessories

Part No.	Description	Dimensions	Material	Bag Quantity
C2018-19	Trim Ring	21/32" Dia.	Plastic	25
C7015-2C	5/16" Offset Cam	1-1/16 to hook	Steel	25
C7020-2C	Pin Cam	1"	Die Cast	25
C7021-2C	Pin Cam	1-1/2"	Die Cast	25
C7022-2C	Pin Cam	1-7/8"	Die Cast	25

Note: Order by number of pieces, not by bag. Full bags only. Orders must be in multiples of 25 pieces.

Fits 17mm Hole



C2018



C7020



C7021



C7022



C7015

disc tumbler central locking systems

For convenience, we have gathered together in one package all components, fasteners and installation guidelines to provide security for three typical wood office furniture applications.

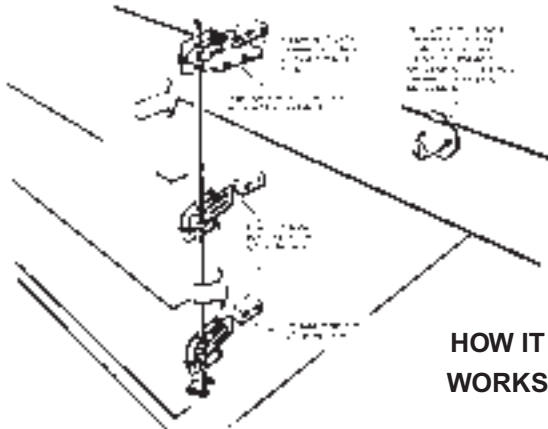

HOW IT WORKS

For simplification, only one pedestal application is shown.

CENTER DRAWER LOCKING

APPLICATION – For installing in wood desks with center drawer and up to six side drawers, three per pedestal. Drawer lock is installed in center drawer.

OPERATION – Movement of the center drawer operates the system. When center drawer is closed, the closing motion is transferred to the pedestals via mounted ramps. Flags are pivoted into the path of side drawer mounted stops preventing opening of side drawers.

KEYING – Will key together with all other disc tumbler locks using D8785 key blank. See table for available keying. Master keying to E41A using D8783 key blank.

PACKAGING – Supplied with two keys and all components shown and necessary mounting screws. See installation sheet for complete parts listing.

Part No.	Bolt Type	Cyl. Length	Bolt Throw	KA* Codes	KD Changes	Case Qty.	Non MK Key Blank
D8950-3	Dead	15/16"	11/32"	1	100	5	D8785
D8950-4G	Dead	15/16"	11/32"	1	100	5	D8785

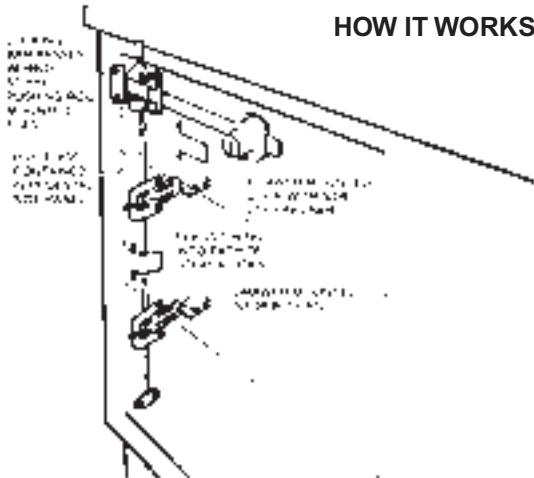

HOW IT WORKS

PEDESTAL LOCKING

APPLICATION – For multiple drawer locking of wood desk pedestal only or mobile pedestal unit. Bar lock is installed in top drawer. For inside case width up to 15-1/2".

OPERATION – Locking the top drawer rotates rod with attached flags which pivot into path of drawer mounted stops preventing opening of lower drawers.

KEYING – Will key together with all other disc tumbler locks using D8785 key blank. See table for available keying. Master keying to E41A using D8783 key blank.

PACKAGING – Supplied with two keys and all components shown and necessary mounting screws. See installation sheet for complete parts listing.

Part No.	Bar Operation	Cyl. Length	Bolt Throw	KA* Codes	KD Changes	Case Qty.	Non MK Key Blank
D8951-3	Reversible	15/16"	11/32"	1	100	5	D8785
D8951-4G	Reversible	15/16"	11/32"	1	100	5	D8785

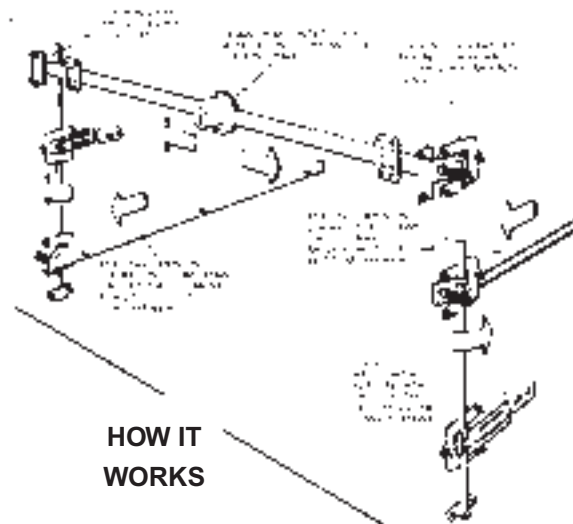

HOW IT WORKS

LATERAL FILE LOCKING

APPLICATION – For wood constructed two drawer lateral files with inside case width up to 42". Double throw bar is installed in top drawer.

OPERATION – Lateral files require "anti-tilt" performance of the hardware for safe operation. This permits only one drawer at a time to be opened. Opening a drawer results in a side mounted rail rotating the adjacent rod. Attached flag swings into path of stop mounted on other drawer preventing its opening. Locking the top drawer produces the same "lock-up" described above.

KEYING – Will key together with all other disc tumbler locks using D8785 key blank. See table for available keying. Master keying to E41A using D8783 key blank.

PACKAGING – Supplied with two keys and all components shown and necessary mounting screws. See installation sheet for complete parts listing.

Part No.	Bar Operation	Cyl. Length	Bolt Throw	KA* Codes	KD Changes	Case Qty.	Non MK Key Blank
D-8952-3	Double	15/16"	11/32"	1	100	5	D8785
D8952-4G	throw	15/16"	11/32"	1	100	5	D8785

*Key Codes used: 1 Code – C415A.

furniture locks

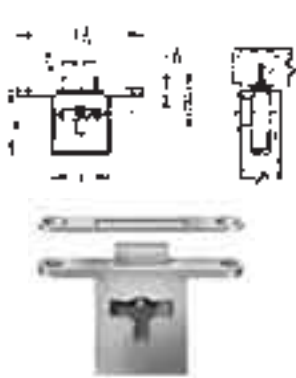

C8252, C8253

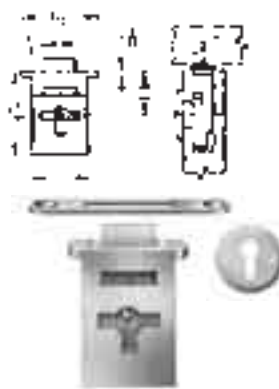

C8207

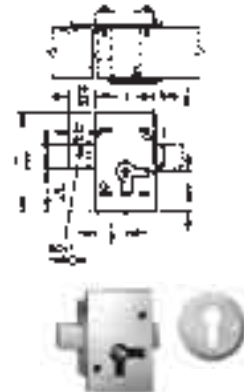

C8826

APPLICATION – This group of locks is used primarily on furniture and other fine cabinetry. C8826 is surface mounted and requires hole for key entry, all other locks require full 11/32" x depth of lock. Additional mortising, required for lock selvage plus hole for key entry.

OPERATION – Key removable in both locked and unlocked positions.

KEYING – Each lock furnished keyed alike.

PACKAGING – Supplied with one key. All locks except C8826 are supplied with strikes. Key hole escutcheons are packed with C8207 and C8826.

Part No.	Installation	Bolt Type	Bolt Travel	Case Quantity	Reference Number	Key Blank
C8207-3	R.H. Door, Drawer, Full Mortise	Dead	3/16"	25	N0-0274-001	D8890
C8252-3	R.H. Door, Drawer, Full Mortise	Dead	3/16"	25	N0-0252-001	D8890
C8253-3	L.H. Door, Full Mortise	Dead	3/16"	25	N0-0252-002	D8890
C8826-3	Door/Drawer, Surface Mounted	Dead	21/64"	25	N0-0826-001	D8890

chest/lid locks



C8414
(Replaces C8412)



C8384



APPLICATION – Lid locks for cedar chest application and other lid locking requirements. C8414 is surface mounted and requires a 9/16" dia. hole for cylinder. C8384 requires 11/32" wide x depth of lock full mortise plus mortise for selvage plus hole for key entry.

OPERATION – Key removable in both locked and unlocked positions. C8414 has a safety feature requiring operation of pushbutton to lock or latch lid closed.

KEYING – Each lock furnished keyed alike.

PACKAGING – Supplied with one key. Appropriate strikes and mounting screws supplied with locks with additional keyhole escutcheon furnished with C8384.

Part No.	Installations	Bolt Type	Cylinder Length	Bolt Travel	Case Quantity	Reference Number	Key Blank
C8384-3	Chest Lid, Full Mortise	Hook	—	5/16" .200" side shift	25	N0-0384-001	D8890
C8414-4G	Chest Lid, Surface Mounted	Internal, Engages Strike	7/8"	—	25	N0-8414-001	D8194

disc tumbler handle locks

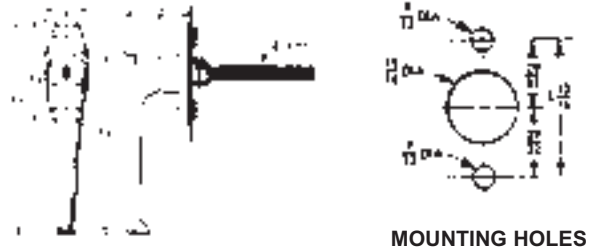
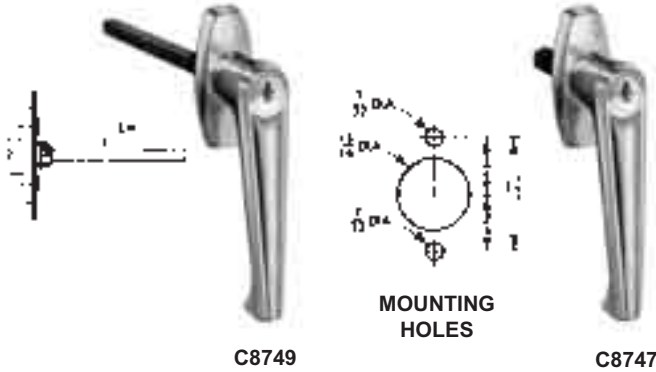
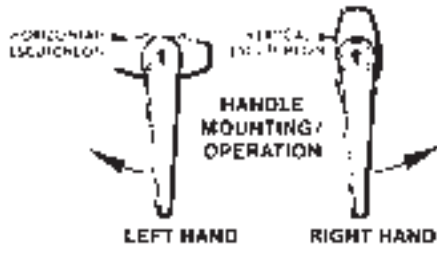

APPLICATION – For doors on metal lockers and cabinets. For R.H. doors, install with escutcheon vertical. For L.H. doors, install with escutcheon horizontal. See above drawings. Choice of spindle lengths and mounting. Spindles accept both C8756 latch plate and C8757 tongue except C8747 which has 8-32 tapped end hole and C8749 which will accept only the C8757 tongue. Spindles can be cut to fit special requirements.

OPERATION – Key removable in both locked and unlocked positions.

KEYING – Will key together with all other disc tumbler locks using D8785 key blank. See table for available keying.

PACKAGING – Supplied with two keys (except C8755) and mounting hardware.

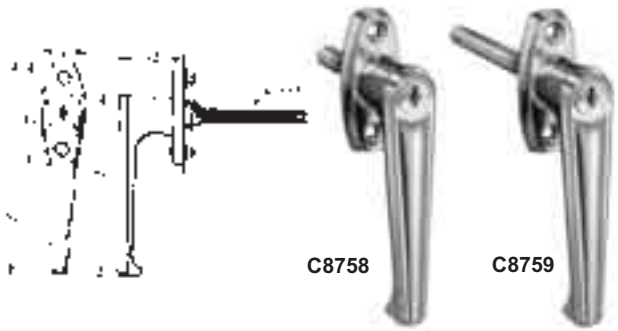

Part No.	Type of Mounting	Spindle Length	Direction of Turn to Open	KA* Codes	Key			Reference Number	Non MK Key Blank
					Changes KD	Case Qty			
C8747-26D	Rear	1" **	90° c/cw	1	200	10	M4-0428-420	D8785	
C8749-26D	Rear	4" †	90° c/cw	1	200	10	M4-0428-293	D8785	
C8751-26D	Rear	1"	90° c/cw	3	200	10	M4-0428-620	D8785	
C8754-26D	Rear	3"	90° c/cw	3	200	10	M4-0428-684	D8785	
C8755-26D††	Thru-the Escutcheon	3"	90° c/cw	—	—	10	M6-0429-684	—	
C8758-26D		1"	90° c/cw	3	200	10	M4-0294-620	D8785	
C8759-26D		3"	90° c/cw	3	200	10	M4-0294-684	D8785	

*Key Codes used: 1 Code – C415A.

3 Codes – C413A, C415A and C420A.

**5/16" sq. spindle w/ 8-32 tapped end hole.

†5/16" sq. spindle

††Non-Locking Handle.



LATCH PLATE & TONGUE FOR ABOVE HANDLE LOCKS

Part No.	Description	Method of Attachment to Spindle	Case Quantity	Reference Number
C8756-2C	3 Point Latch Plate with Tongue, Used with Locking Bars	Hex Nuts with Lock Washers Threaded on Spindle	25	M3-6931-001
C8757-2C	Single Point Latch Tongue	Side Mounted Set Screw	25	H2-0082-003

disc tumbler circuit breaker cabinet locks

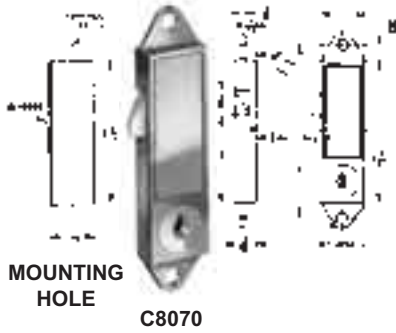

APPLICATION – For right handed metal doors of electrical circuit breaker cabinets.

OPERATION – Key removable in both locked and unlocked positions. Push plate operates spring bolt. Unlocked, push plate acts as spring latch.

KEYING – Supplied keyed alike only to B135A.

PACKAGING – Supplied with two keys; no mounting hardware.

Part No.	Type of Mounting	Bolt Type	Bolt Travel	Case Quantity	Reference Number	Key Blank
C8070-2C*	R.H. Door	Spring Pivot	7/32"	10	M4-0226-001	D8786

*Aluminum Enamel Finish.

garage door mechanism-locking handle

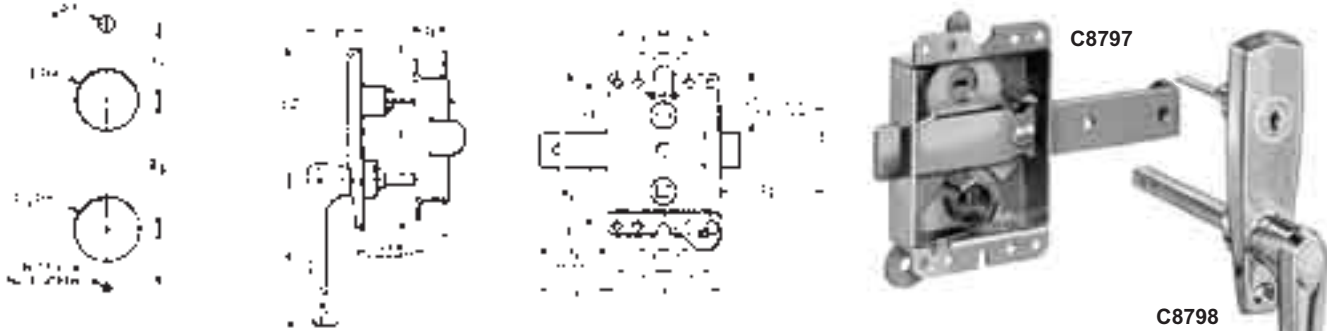

MOUNTING HOLES FOR HANDLE

APPLICATION – For mounting on sectional overhead doors. Factory assembled for R.H. mounting. Mechanism installs at right side of door (inside garage) to lock into track. Handle can replace Overhead Door locking handles. Mechanism can be reversed for L.H. application.

OPERATION – Turning key releases mechanism, unlocking door. Handle turns down to vertical position.

Turn handle to horizontal to lock door. Key removable in both locked and unlocked positions.

KEYING – Available keyed differently only (10 changes).

PACKAGING – C8797 furnished with mounting screws. C8798 supplied with two keys and mounting screws.

Part No.	Installation	Operation	Key Changes KD	Case Quantity	Reference Number	Key Blank
C8797-2C	Inside door near track	Sliding bolt locks into track	—	5	M6-0492-001	—
C8798-26	Outside door over mechanism	Key releases bolt, Handle locks bolt	10	5	M4-0498-001	D8785

cooler locking handle & replacement plugs

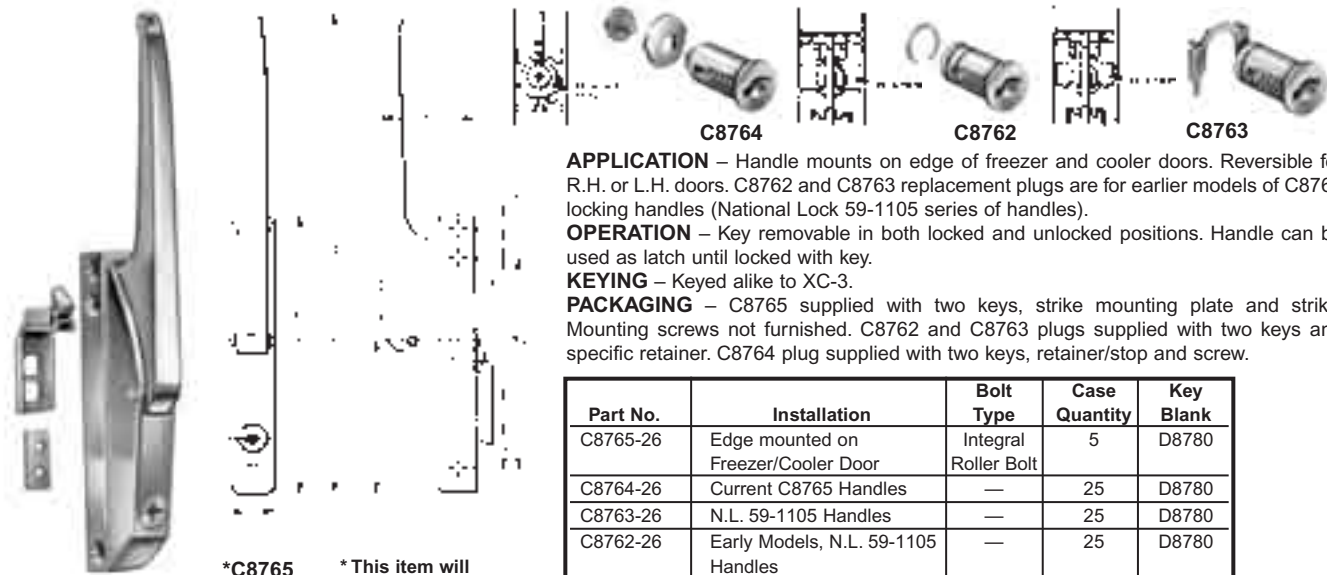

APPLICATION – Handle mounts on edge of freezer and cooler doors. Reversible for R.H. or L.H. doors. C8762 and C8763 replacement plugs are for earlier models of C8765 locking handles (National Lock 59-1105 series of handles).

OPERATION – Key removable in both locked and unlocked positions. Handle can be used as latch until locked with key.

KEYING – Keyed alike to XC-3.

PACKAGING – C8765 supplied with two keys, strike mounting plate and strike. Mounting screws not furnished. C8762 and C8763 plugs supplied with two keys and specific retainer. C8764 plug supplied with two keys, retainer/stop and screw.

Part No.	Installation	Bolt Type	Case Quantity	Key Blank
C8765-26	Edge mounted on Freezer/Cooler Door	Integral Roller Bolt	5	D8780
C8764-26	Current C8765 Handles	—	25	D8780
C8763-26	N.L. 59-1105 Handles	—	25	D8780
C8762-26	Early Models, N.L. 59-1105 Handles	—	25	D8780

*C8765
*This item will be discontinued when inventory is depleted.

lever tumbler door lock

APPLICATION – Surface mounted lock, hole required for cylinders. C8422 used on doors with narrow stiles such as display cases with wood framing.

OPERATION – Key removable in both locked and unlocked positions.

KEYING – Each lock furnished keyed alike.

PACKAGING – Supplied with mounting screws and two keys.

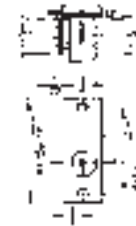

Part No.	Installation	Bolt Type	Cylinder Length	Bolt Travel	Case Quantity	Reference Number	Key Blank
C8422-3	Door	Dead	7/8"	7/32"	25	N0-2422-097	—

strikes, escutcheon, flat washer

Our most popular strikes are offered in two finishes. They are furnished with screws finished to match the strike.

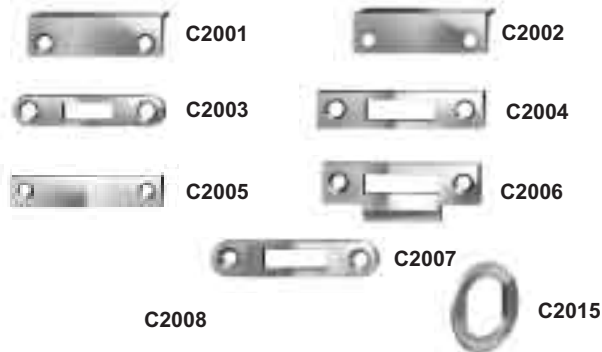

Ornamental escutcheon for furniture. Supplied with mounting pins

Flat washer used to convert 3/4" dia. holes in steel fronts to a double "D" hole for installing cam locks. Spot weld to back-side of hole.

7/8" dia. trim ring to be used to cover ragged edges around bored mounting holes.

Mounting plate for cylinder cam locks, screw mounted. Used where spur washer will not embed into hard surface. Packed 25 pcs. per bag.

Part No.	Description	Overall Dimensions	Qty Per Bag
C2001-14A	Formed strike, no bolt hole	1-3/4" x 1/2" with 3/16" form	25
C2001-3			25
C2002-14A	Formed strike, no bolt hole countersunk holes reversed	1-3/4" x 1/2" with 3/16" form	25
C2002-3			25
C2003-14A	Flat strike with rounded ends, 3/4" x 7/32" bolt hole	1-15/16" x 3/8"	25
C2003-3			25
C2004-14A	Flat strike with square ends, 7/8" x 17/64" bolt hole	2-5/32" x 1/2"	25
C2004-3			25
C2005-14A	Flat strike, no bolt hole	1-15/16" x 3/8"	25
C2005-3			25
C2006-14A	Flat strike with sq. ends and 15/16" x 1/4" tongue, 15/16" x 1/4" hole	2" x 3/4"	25
C2006-3			25
C2007-14A	Flat strike with rounded ends, 1-1/16" x 17/64" bolt hole	2-5/32" x 1/2"	25
C2007-3			25
C2008-3	Key hole escutcheon	1" Dia.	50
C2015-2C	Flat washer for cam locks	1-1/8" Dia.	25
C2016-2C	Mounting plate for cam locks Screw mounted, use No. 8 screws, not furnished.	2-3/16" x 1-1/4"	25
C2017-14A	Trim ring for all locks with a 7/8" mounting hole.	7/8" Dia.	25
C2017-26D			25
C2017-3			25
C2017-4			25
C2017-4G			25

Note: Order by number of pieces, not by bag. Full bags only. Orders must be in multiples of 25 or 50 pieces.

disc tumbler cams

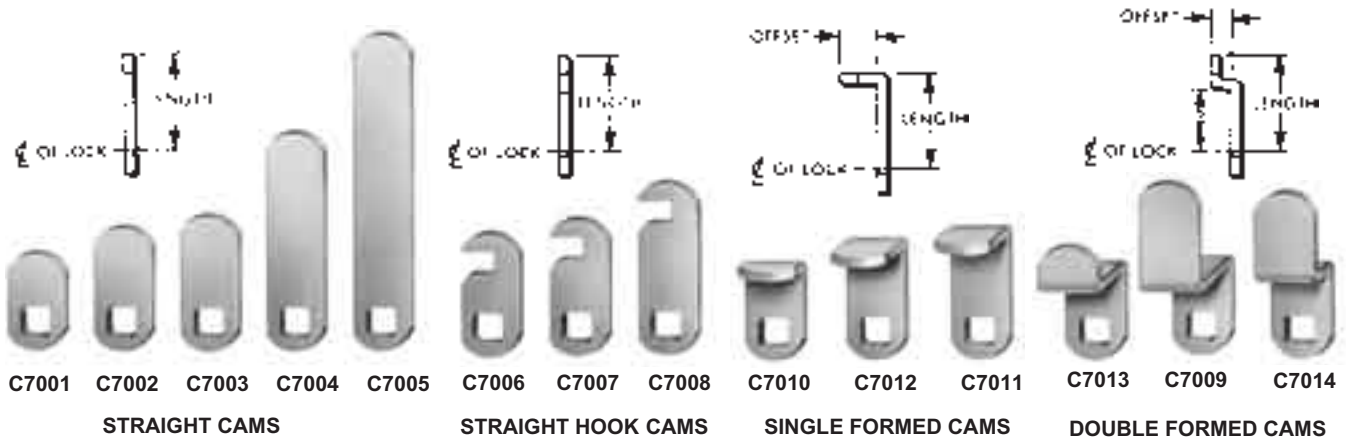

Selection of cams that permit adaption of disc tumbler cylinder cam locks to meet nearly every application need.

Straight Hook Cams and Double Formed Cams can be reversed when required.

Part No.	Description	Length	Qty Per Bag	Part No.	Description	Length	Offset	Qty Per Bag
C7001-2C	Straight Cam	3/4"	25	C7008-2C	Straight Hook Cam	1-1/2"	—	25
C7002-2C	Straight Cam	1"	25	C7009-2C	Double Formed Cam	1-3/4"	1/2"	25
C7003-2C	Straight Cam	1-1/8"	25	C7010-2C	Single Formed Cam	5/8"	7/32"	25
C7004-2C	Straight Cam	2"	25	C7011-2C	Single Formed Cam	1-1/8"	7/16"	25
C7005-2C	Straight Cam	3"	25	C7012-2C	Single Formed Cam	1"	7/16"	25
C7006-2C	Straight Hook Cam	1"	25	C7013-2C	Double Formed Cam	1-1/8"	3/8"	25
C7007-2C	Straight Hook Cam	1-1/8"	25	C7014-2C	Double Formed Cam*	1-5/8"	5/16"	25

*For overlay construction using 3/4" thick front and 3/4" thick frame material. Use with C8053 disc tumbler lock.

pin tumbler cams

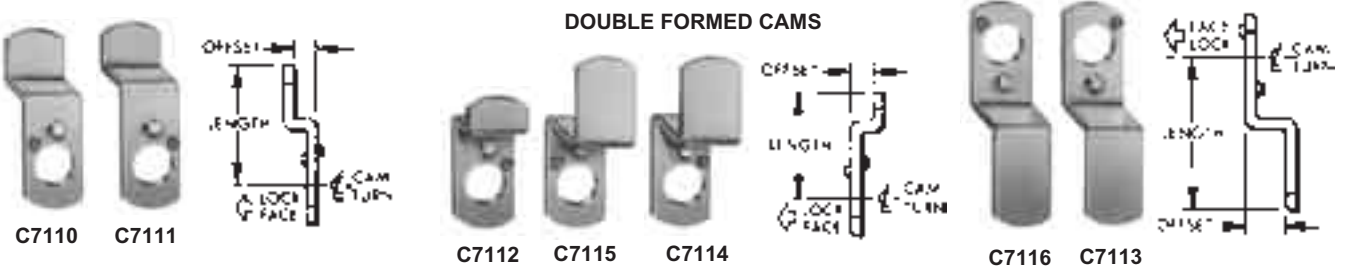

Cams for pin tumbler cylinder cam locks. All cams have dual function. See "Applications" column in table for details.

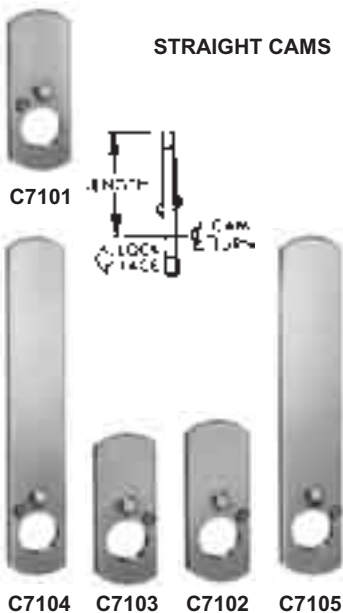

Applications Solid lines show locked position of cam	Position of shifter on back of lock	Part No.	Description	Length	Offset	Qty Per Bag
		C7101-2C	Straight Cam	1-1/4"	—	20
		C7104-2C	Straight Cam	3"	—	20
		C7110-2C	Double Formed Cam	1-1/4"	9/32"	20
		C7115-2C	Double Formed Cam*	1-5/8"	7/16"	20
		C7102-2C	Straight Cam	1-1/4"	—	20
		C7103-2C	Straight Cam	1-1/8"	—	20
		C7105-2C	Straight Cam	3"	—	20
		C7111-2C	Double Formed Cam	1-1/4"	9/32"	20
		C7112-2C	Double Formed Cam	1-1/8"	1/4"	20
		C7114-2C	Double Formed Cam*	1-5/8"	7/16"	20
		C7113-2C	Double Formed Cam*	1-5/8"	7/16"	20
		C7116-2C	Double Formed Cam*	1-5/8"	7/16"	20

*For overlay construction using 3/4" thick front and 3/4" thick frame material. Use with C8102 pin tumbler locks.

Note: Order by number of pieces, not by bag. Full bags only. Orders must be in multiples of 25 or 20 pieces.

original pin tumbler key blanks

IDENTIFYING KEY BLANKS

Blanks are listed with related actual size cross section.



Sight down the end of the blank to identify the cross section or profile.

PIN TUMBLER BLANKS

- 3 Pin Tumbler
D4290
- 4 Pin Tumbler
D4291
- 5 Pin Tumbler
D4292
- 5 Pin Tumbler
D4293

4 PIN TUMBLER BLANKS



5 PIN TUMBLER BLANK



Part No.	Description	Material	Carton Quantity	Reference Number
D4290	3 Pin Tumbler	Brass	50	M3-0679-111
D4291	4 Pin Tumbler	Brass	50	M3-0558-111
D4292	5 Pin Tumbler	Brass	50	M3-0676-111
D4293	5 Pin Tumbler	Brass	50	M3-0676-211
D4295	5 Pin Tumbler	Brass	50	M3-0600-111
D4296	4 Pin Tumbler (short)	Brass	50	M3-5655-111
D4297	4 Pin Tumbler (long)	Brass	50	M3-5450-212

original disc tumbler key blanks

4 DISC TUMBLER BLANKS



- D8780 D
- D8781 E
- D8782 C
- D8790 R

5 DISC TUMBLER BLANKS



- D8783 D
- D8784 E
- D8785 C
- D8786 B
- D8791 R
- D8792 N
- D8793 M
- D8794 K

6 DISC TUMBLER BLANKS



- D8787 D
- D8788 E
- D8789 C
- D8795 N
- D8796 M
- D8798 K

5 or 6 DISC TUMBLER REVERSIBLE KEY BLANKS



Part No.	Description	Material	Carton Quantity	Reference Number
D8776	5 Disc Tumbler Pass Key	Brass	50	P5-6613-301
D8777	5 or 6 Disc Tumbler Pass Key	Brass	50	M5-0650-111
D8778	5 or 6 Disc Tumbler Pass Key	Brass	50	M5-0650-906
D8780	4 Disc Tumbler Pass Key	Brass	50	M5-0682-111
D8781	4 Disc Tumbler Master Key	Brass	50	M5-0682-112
D8782	4 Disc Tumbler Pass Key	Brass	50	M5-0688-111
D8790	4 Disc Tumbler Pass Key	Brass	50	M5-0693-111
D8783	5 Disc Tumbler Pass Key	Brass	50	M5-0680-111
D8784	5 Disc Tumbler Master Key	Brass	50	M5-0680-112
D8785	5 Disc Tumbler Pass Key	Brass	50	M5-0687-111
D8786	5 Disc Tumbler Pass Key	Brass	50	M5-0691-111
D8787	6 Disc Tumbler Pass Key	Brass	50	M5-0694-117
D8788	6 Disc Tumbler Master Key	Brass	50	M5-0694-119
D8789	6 Disc Tumbler Pass Key	Brass	50	M5-0694-115
D8791	5 Disc Tumbler Pass Key	Brass	50	M5-0692-111
D8792	5 Disc Tumbler Pass Key	Brass	50	M5-0695-114
D8793	5 Disc Tumbler Pass Key	Brass	50	M5-0695-112
D8794	5 Disc Tumbler Master Key	Brass	50	M5-0695-113
D8795	6 Disc Tumbler Pass Key	Brass	50	M5-0694-113
D8796	6 Disc Tumbler Pass Key	Brass	50	M5-0694-112
D8798	6 Disc Tumbler Master Key	Brass	50	M5-0694-114

All Disc Tumbler Key Blanks, D8780 through D8798, are stamped with last two digits of part number to aid in identification. Example: D8788 is stamped "88".

original lever tumbler key blanks

FLAT LEVER TUMBLER BLANKS



PARACENTRIC LEVER TUMBLER BLANKS



Part No.	Description	Material	Carton Quantity	Reference Number
D8194	Lever Tumbler (cut) – Flat	Steel	50	N1-8414-105
D8192	Lever Tumbler Blank – Flat	Steel	50	N1-0651-101
D8193	Lever Tumbler Blank – Flat	Steel	50	N1-0656-113
D8490	Lever Tumbler Blank – Paracentric	Brass	50	N1-0681-111
D8491	Lever Tumbler Blank – Paracentric	Brass	50	N1-0640-119

original master keys



Part No.	Description	Material	Reference Number
D4299	Pin Tumbler GM1 Master key	Brass	M3-0686-399
D8419	Lever Tumbler 5LM Flat Master key	Steel	N1-0651-399
D8799	Disc Tumbler E41A Master key	Brass	M5-0680-399
D8999	Disc Tumbler E13A Master key	Brass	M5-0680-399

keys

FREEZER LOCK KEYS



WARDER BARREL KEY



Part No.	Description	Material	Carton Quantity	Reference Number
D8590	Freezer Lock Key Wrench – Cross Shape	Die Cast	50	N5-0811-001
D8591	Freezer Lock Key Wrench – Pentagon Shape	Die Cast	50	N5-0812-001
D8890	Warded Barrel Key	Die Cast	50	M5-0689-102

key code books

D8001 Pin Tumbler Key Codes — Includes the most popular National key codes: GM1 series, GM2 series, GM2A series, GM300 series, GM600 series and GM700 series.



D8002 Disc Tumbler and Lever Tumbler Key Codes — Includes the most popular National key codes: standard 4 tumbler series, standard 5 tumbler series, standard 6 tumbler series, 5 tumbler prefix RD series, 5 tumbler prefix GF series, 5 tumbler prefix SK and KS series, 6 tumbler prefix SK and KS series and 5 lever tumbler series 8LLT.

keying kits



V70P-1



V70P-2



V71D-3



V71D-4

V70P-1 Pin Tumbler Keying Kit – Includes:

- 100 Pcs. ea. 1, 2, 3 and 4 Drivers.
- 100 Pcs. ea. 0, 1, 2, 3, 4, 5, 6, 7, 8 and 9 Tumblers.
- 250 Pcs. Tumbler Springs
- 100 Pcs. Tumbler Retainers
- 50 Pcs. ea. C3735 and C3738 Plug Retainers.

V70P-2 Pin Tumbler Master Keying Kit – Includes:

- 100 Pcs. ea. 2, 3, 4, 5, 6, 7, 8 and 9 Master Drivers.

V71D-3 Disc Tumbler Keying Kit – Includes:

- 100 Pcs. ea. 00, 22, 44 and 66 Tumblers.
- 250 Pcs. Tumbler Springs.

V71D-4 Disc Tumbler Master Keying Kit – Includes:

- 100 Pcs. ea. 02, 04, 06, 20, 24, 26, 40, 42, 46, 60, 62 and 64 Tumblers.
- 250 Pcs. Tumbler Springs.

keying kit replacement parts



**PIN TUMBLER
KEYING KIT
REPLACEMENT
PARTS**

**DISC TUMBLER
KEYING KIT
REPLACEMENT
PARTS**



Part No.	Description	Identifying Color	Qty Per Bag	Part No.	Description	Qty Per Bag
C3730	#1 Driver	Blue	250	D6676	5 Pin Tumbler Depth Keys – Set of 10 Keys	1 Set
C3731	#2 Driver	Slate Gray	250	D6680	5 Disc Tumbler Depth Keys – Set of 4 Keys	1 Set
C3732	#3 Driver	Copper	250	D6682	4 Disc Tumbler Depth Keys – Set of 4 Keys	1 Set
C3733	#4 Driver	Violet	250	D6686	4 Pin Tumbler Depth Keys – Set of 10 Keys	1 Set
C3734	Plug Retainer	—	100	C6782	#00 Tumbler	250
C3735	Plug Retainer	—	100	C6783	#22 Tumbler	250
C3736	Tumbler Retainer	—	100	C6784	#44 Tumbler	250
C3737	Tumbler Spring	—	500	C6785	#66 Tumbler	250
C3738	Plug Retainer	—	100	C6786	#02 Tumbler	250
C3740	#2 Master Driver	Violet	250	C6787	#04 Tumbler	250
C3741	#3 Master Driver	Red	250	C6788	#06 Tumbler	250
C3742	#4 Master Driver	Blue	250	C6789	#20 Tumbler	250
C3743	#5 Master Driver	Fuchsia	250	C6790	#24 Tumbler	250
C3744	#6 Master Driver	Slate Gray	250	C6791	#26 Tumbler	250
C3745	#7 Master Driver	Brass	250	C6792	#40 Tumbler	250
C3746	#8 Master Driver	Copper	250	C6793	#42 Tumbler	250
C3747	#9 Master Driver	Brown	250	C6794	#46 Tumbler	250
C3750	#0 Tumbler	Silver	250	C6795	#60 Tumbler	250
C3751	#1 Tumbler	Black	250	C6796	#62 Tumbler	250
C3752	#2 Tumbler	Violet	250	C6797	#64 Tumbler	250
C3753	#3 Tumbler	Red	250	C6798	Tumbler Spring	500
C3754	#4 Tumbler	Blue	250			
C3755	#5 Tumbler	Fuchsia	250			
C3756	#6 Tumbler	Slate Gray	250			
C3757	#7 Tumbler	Brass	250			
C3758	#8 Tumbler	Copper	250			
C3759	#9 Tumbler	Brown	250			

sample boards

CAM LOCKS Pin Tumbler

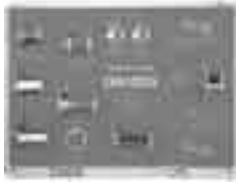

V69B-1 Board

V69B-1 Board displays C8101, C8102, C8103, C8106, C8108, C8109 and C8183 (C8188), with "The Advantage Plus" feature.

Help your customers select the right lock. Sample boards are invaluable aids to complete a sale. CompX National display boards make your business the center for quality locks. Boards are organized by type of locks and can be hung or fastened in place. Available individually or in sets. All boards finished with descriptive information.

DOOR & DRAWER LOCKS Pin Tumbler



V69B-2 Board

V69B-2 Board displays pin tumbler door and drawer locks with "The Advantage Plus" feature, C8163, C8173 and C8178. Also shown, C8131, C8133 and C8139; along with furnished strikes.

MAIL BOX LOCKS Pin Tumbler



V69B-3 Board

V69B-3 Board displays pin tumbler mail box locks, C8710 thru C8726. 17 locks total.

MAIL BOX LOCKS Multi-Cam-Pin Tumbler



V69B-4 Board

V69B-4 Board displays the popular C8730 and C8735 mail box locks; each having a selection of five cams to meet specific mounting requirements.

SLIDING DOOR LOCKS- SPECIAL USE LOCKS



V69B-5 Board

V69B-5 Board displays C8043, C8140 and C8142 sliding door locks. Also includes C8402 locker lock, C8154 knob lock, C8150 file cabinet lock, C8070 panel lock, and C8065 screwdriver Cam Latch.

CAM LOCKS Disc Tumbler



V69B-6 Board

V69B-6 Board displays disc tumbler cam locks C8051 thru C8055, with reference to C8073 and C8075 flexafunction locks. C8060 and C8080 with flexafunction feature. Also shown is C8062.

HANDLE LOCKS Disc Tumbler



V69B-7 Board

V69B-7 Board displays C8747, C8751 and C8759 representing a selection of handle locks. Also displayed are C8756 and C8757 latch plate and tongue.

CAM ASSORTMENT Pin Tumbler - Disc Tumbler STRIKES



V69B-8 Board

V69B-8 Board displays all the available cams for both disc tumbler and pin tumbler cylinder cam locks. Also displayed are examples of available strikes, flat washer and barrel key escutcheon.

FURNITURE LOCKS



V69B-10 Board

V69B-10 Board displays C8384 and C8414 lid locks. Other locks displayed include C8207, C8252, C8826, and C8422, along with furnished strikes and escutcheons.

FURNITURE LOCKS Small Diameter Disc Tumbler



V69B-12 Board

V69B-12 Board displays disc tumbler RemovaCore locks D8840, D8836, D8838, C8834, C8830 and C8850 plug core.

DRAWER & DOOR LOCKS Disc Tumbler



V69B-13 Board

V69B-13 Board displays samples of C8703 thru C8706 locks; C8803 and C8804, D8090 gang lock and C8701 lock with reference to C8137 pin tumbler lock.

28th Edition

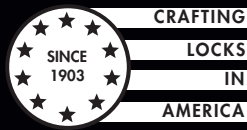

MAIN OFFICE - FACTORY
P.O. Box 200
Mauldin, SC 29662
PH: 864-297-6655 FAX: 864-297-9987
compX.com

WESTERN DISTRIBUTION CENTER
9370 Buffalo Avenue, Unit 104
Rancho Cucamonga, CA 91730
PH: 909-476-7933 FAX: 909-476-8553



Reorder #: F2644-001
September 2007
Printed in U.S.A.

COMPX NATIONAL
REGISTERED TO ISO 9001
CERTIFICATE NO. A 2695

Copyright 2007
© CompX Security Products