

## Cylinder Guard

### MS4043

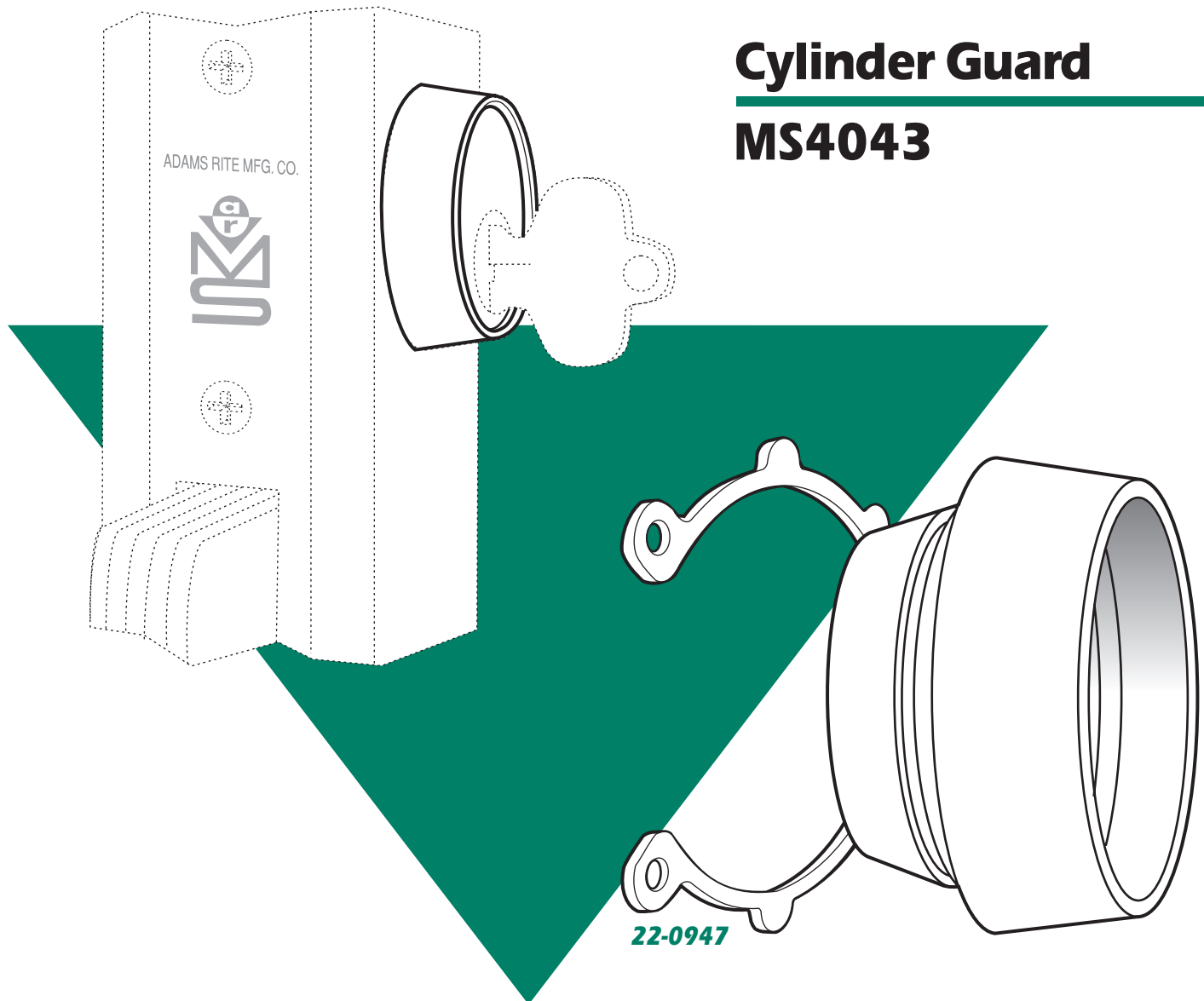

22-0947

#### ▼ Function

The standard mortise cylinder is made of brass. It is literally a soft spot in narrow stile door security. Using special pliers, a pipe wrench or other leverage device, a burglar can tear the cylinder out of the door, leaving an opening through which he can operate the deadlock. Against this problem, the MS4043 cylinder guard offers a three-way defense: First, the outer shield ring is fully beveled to offer poor purchase for either prying or twisting. Second, this ring is hardened steel so that the combination of shape and hardness make it virtually impossible to grip, even with sharpened tools. Third, in the event that a prying tool, such as a cold chisel, can be driven into the stile behind the shield ring, the would-be burglar is obliged to pull a heavy steel plate through a round hole in the 1/8" metal door stile. This degree of leverage is far beyond that available with most hand tools.

#### ▼ Security Ring

Made of hardened steel. Free-swiveling when properly installed.

#### ▼ Retainer Ring

Hardened steel, plated for corrosion resistance. Permits security ring to swivel.

#### ▼ Trim Finish

Zinc plated (603). Contact factory for other available finishes.



**ADAMS RITE**  
MANUFACTURING CO.

260 Santa Fe Street  
Pomona, California 91767  
(800) 872-3267 Fax:(800) 232-7329  
www.adamsrite.com



# MS4043 Cylinder Guard

## DIMENSIONS

INCHES  
MILLIMETERS

Nominal, subject to tolerance extremes.

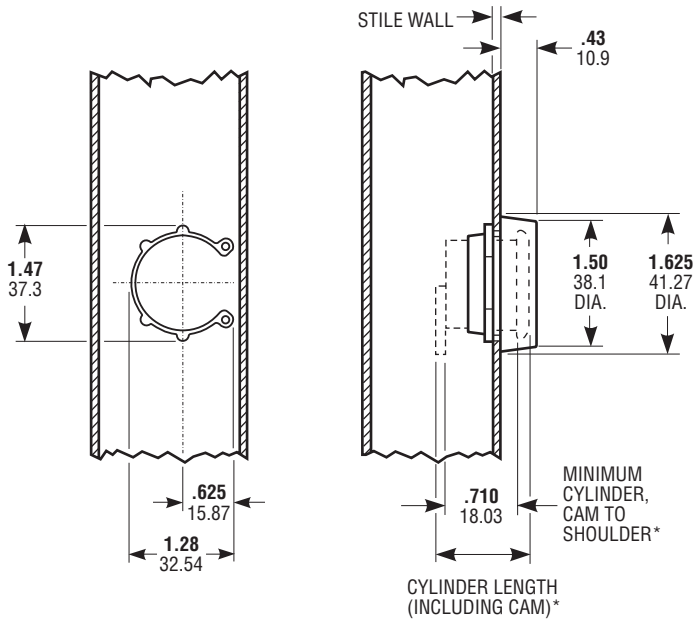

\*Contact factory regarding non-standard dimensions.

## INSTALLATION

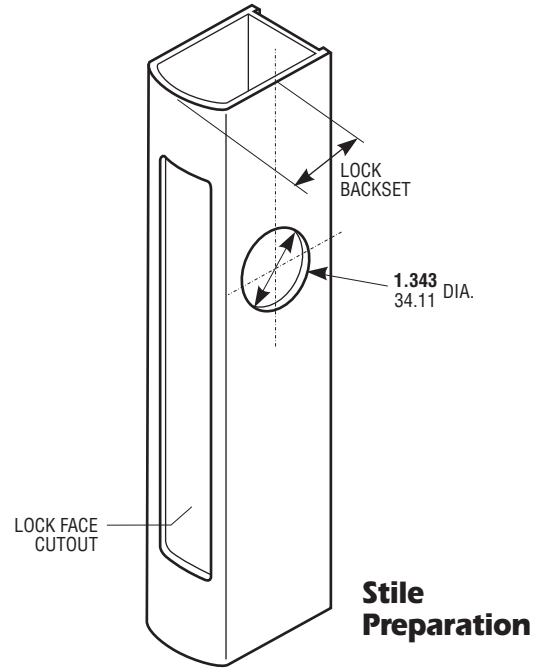

FACE "OPEN" SIDE OF RETAINER TOWARD MINIMUM CLEARANCE DIRECTION (TOWARD NOSE OF DOOR ON 7/8" OR 31/32" BACKSET LOCKS, AWAY ON 1-1/8" BACKSET).

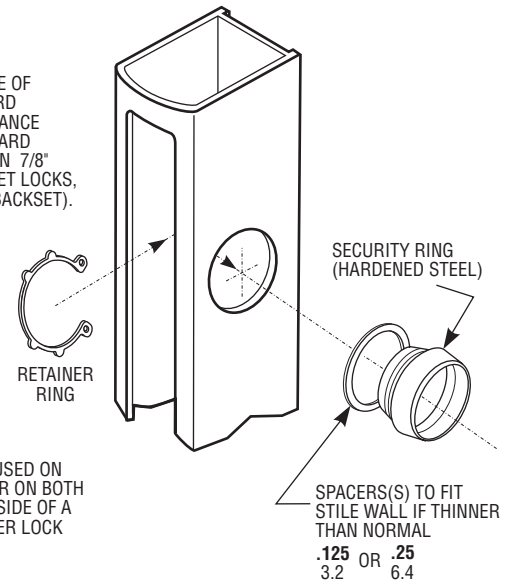

NOTE:  
GUARD MAY BE USED ON OUTSIDE ONLY OR ON BOTH OUTSIDE AND INSIDE OF A DOUBLE-CYLINDER LOCK

## HOW TO ORDER

Specify quantity and the following information.  
Order related hardware separately.

	Stile Wall	Cylinder
<b>00</b>	1/8" (3.2mm)	5 or 6 PIN
<b>01</b>	1/4" (6.4mm)	5 or 6 PIN
<b>02</b>	1/8" (3.2mm)	1.31" to 1.435" long

# MS4043 - 01 - 603

### Finish

- 121** Dark Bronze
- 119** Satin Black
- 130** Satin Aluminum
- 603** Zinc on Steel

## OPTIONS

MS4043 fits standard 1/8" stile wall. For 1/4" thick stile wall, specify MS4043-01. See page SW-28 for cylinder information.

## STANDARD PACKAGE

Individually packaged with spacers for flush fitting in thin stile walls. Cylinders available at extra cost. Shipping weight: 1/8 lb.