

MS® Deadbolt

Aluminum Stile Doors - 1" x 6-7/8" Faceplate

MS1950 Series

ANSI/BHMA Type E5211 (Grade 1)



NEW!
ALL STAINLESS STEEL
CONSTRUCTION

▼ Cylinder Backset

31/32", 1-1/8" or 1-1/2" only.

▼ Case

Fully stainless steel case and internal components. 1" x 6" x depth. (Depth varies by backset. See table on back page.)

▼ Function

A huge bolt of laminated stainless steel, nearly three inches long, activated by an uncomplicated pivot mechanism, has made this basic MS® Deadbolt the standard of the narrow stile door industry. The length of this bolt provides maximum security for a single leaf door, even a very tall and flexible one or an installation where the gap between door and jamb is greater than it should be.

▼ Bolt

5/8" x 1-3/8" x 2-7/8" with 1-3/8" throw. Eight ply laminated stainless steel. Center ply has Alumina-Ceramic core to defeat any hacksaw attack, including rod-type "super" hacksaws.

▼ Strike

See back page for dimensions of strike slot which can be cut in metal jamb. Trim plate, box strike and armored strike are also available. (See page SW-14.)

▼ Operation

360° turn of key or thumbturn throws or retracts the counterbalanced bolt. Key can be removed only when bolt is in a positively locked or unlocked position. Lock accepts any standard 1-5/32" diameter mortise cylinder or thumbturn from either or both sides. Cylinder must have MS® dimensioned cam. (See page SW-28.)



ADAMS RITE
MANUFACTURING CO.

260 Santa Fe Street
Pomona, California 91767
(800) 872-3267 Fax:(800) 232-7329
www.adamsrite.com



MS1950 Deadbolt

DIMENSIONS

INCHES
MILLIMETERS
Nominal, subject to tolerance extremes.

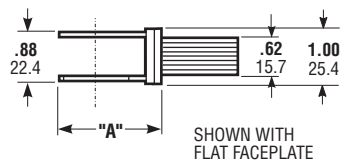

SHOWN WITH
FLAT FACEPLATE

BACKSET	"A"
31/32" 24.6	1.63 41.4
1-1/8" 28.6	1.78 45.2
1-1/2" 38.1	2.25 57.1

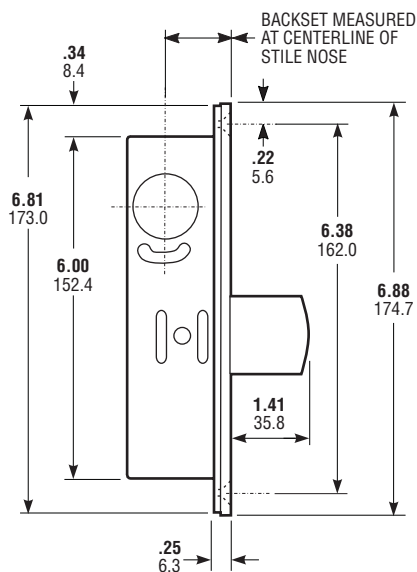

BACKSET MEASURED
AT CENTERLINE OF
STILE NOSE

ARMORED FACEPLATE 1" x 6-7/8"	
FLAT	MS1950
RADIUS	MS1951
RADIUS w/WEATHERSTRIP	MS1951W
LH BEVEL	MS1952-015
RH BEVEL	MS1952-016

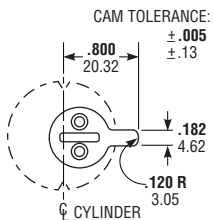

CAM TOLERANCE:
±.005
±.13

Cylinder Cam

MS1950 Series locks are operable by any standard 1-5/32" diameter mortise cylinder with special MS® cam dimensioned as shown. Cylinders with MS® cams can be readily obtained from most cylinder manufacturers. See page SW-28 for cylinder make and trim ring information.

INSTALLATION

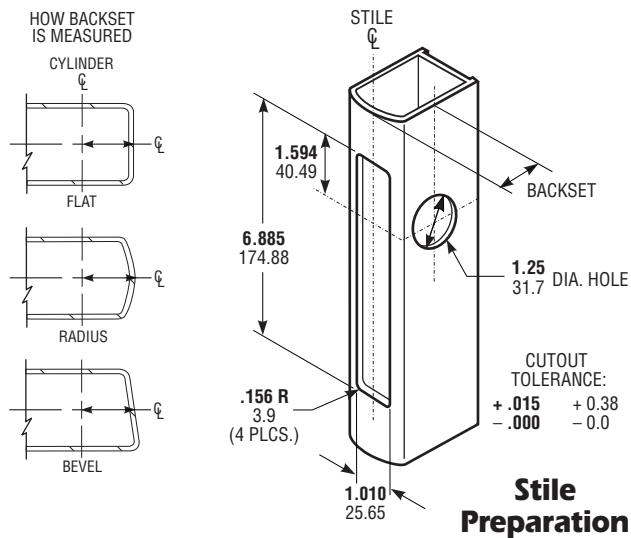

**Stile
Preparation**

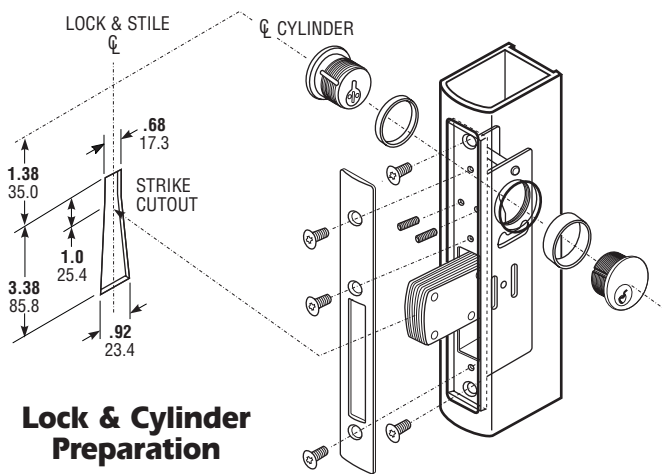

**Lock & Cylinder
Preparation**

HOW TO ORDER

Specify quantity and the following information.
Order related hardware separately.

Faceplate Shape	Backset	Handing
1950 Flat	2 31/32"	15 LH or RHR
1951 Radius	3 1-1/8"	16 RH or LHR
1951W Radius w/w/strip	4 1-1/2"	10 Non-Handed*
1952 Bevel		

MS 1950 - 215 - 628

Finish	
628	Clear Anodized
313	Dark Bronze Anodized
335	Black Anodized

*Any flat or radius face, except Schoolhouse.

OPTIONS

For jambs too narrow to accept the long bolt, the MS1950-050 offers a shorter bolt with hook shape to provide equal security against door-prying attempts. (See catalog page SL-1a) Second and third point locking bolts are available for pairs of doors. (See pages SW-9 and SW-10.) All use any make mortise cylinder and thus can be keyed into systems with other types of doors. "SCHOOLHOUSE" version, also available, is modified so that operation from inside is "unlock only." This lock is handed and must be specified LH or RH. Specify Series SCH1950. Operation from inside, with standard Adams Rite 4066 Thumbturn (page SW-28) or with 4550 Deadlock Lever (page SW-13).

STANDARD PACKAGE

Individually boxed with machine screws for mounting. Cylinders and/or thumbturn available at extra cost. Shipping weight: 1-1/2 lbs. Also available in a 25 unit pack for volume users.