

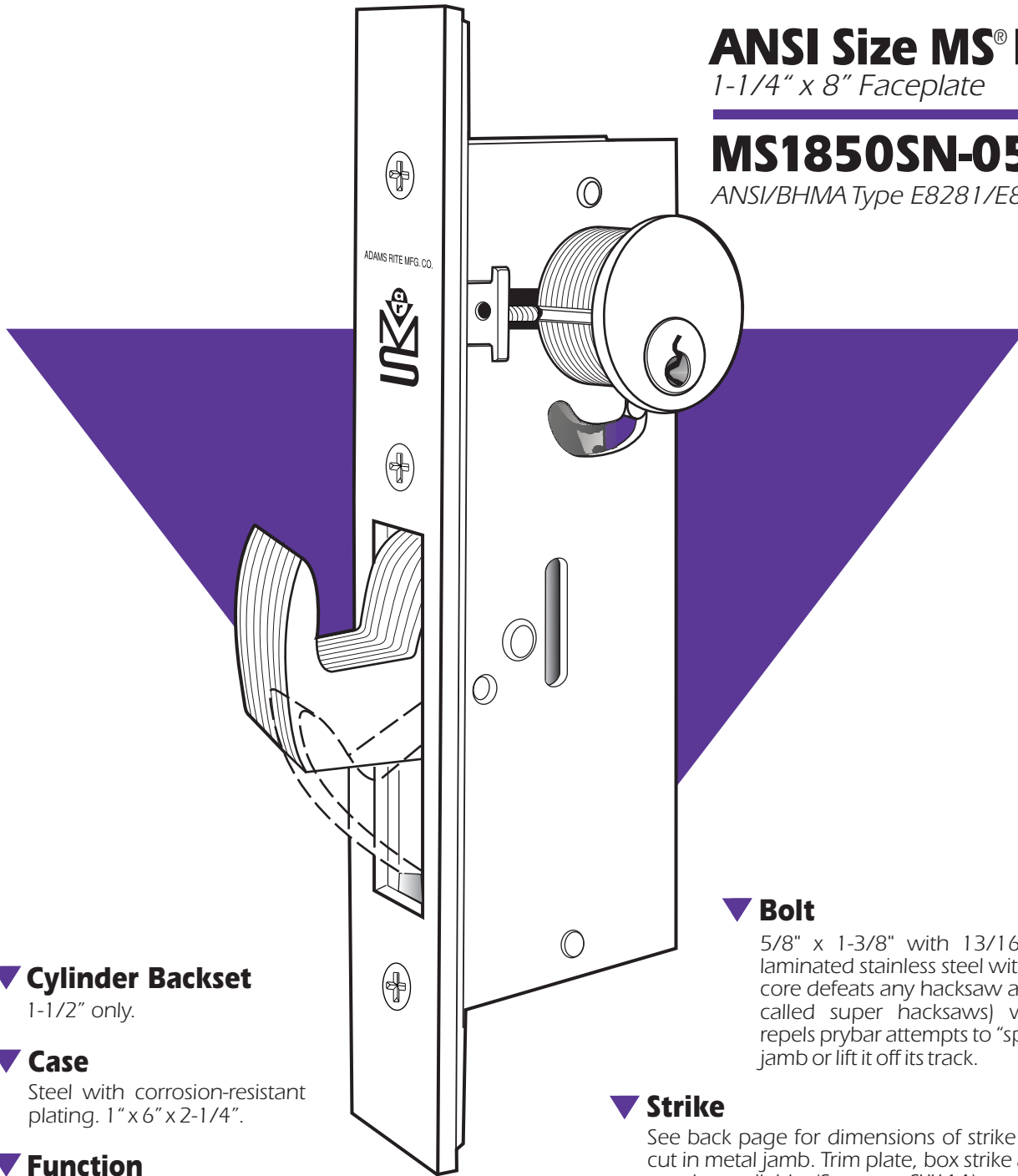

ANSI Size MS® Deadbolt 1-1/4" x 8" Faceplate

MS1850SN-050 Series

ANSI/BHMA Type E8281/E8291 (Grade 1)



▼ Cylinder Backset

1-1/2" only.

▼ Case

Steel with corrosion-resistant plating. 1" x 6" x 2-1/4".

▼ Function

For hollow metal or wood sliding doors prepared for hardware according to the specifications of the American National Standards Institute, this MS® deadbolt provides maximum security and ease of installation. Its standard 1-1/2" backset dimension provides adequate clearance for the deep jamb "pocket" of many commercial and industrial entrances. Also useful for swinging doors closing against jambs too shallow for the 1-3/8" throw of the MS1850SN swinging door deadbolt.

▼ Bolt

5/8" x 1-3/8" with 13/16" throw. Eight-ply laminated stainless steel with Alumina Ceramic core defeats any hacksaw attack (including so-called super hacksaws) while hook shape repels prybar attempts to "spread" door from its jamb or lift it off its track.

▼ Strike

See back page for dimensions of strike slot which can be cut in metal jamb. Trim plate, box strike and armored strike are also available. (See page SW-14).

▼ Operation

360° turn of key or thumbturn throws or retracts the counterbalanced bolt. Key can be removed only when bolt is in a positively locked or unlocked position. Lock accepts any standard 1-5/32" diameter mortise cylinder or thumbturn from either or both sides. Cylinder must have MS® dimensioned cam. (See page SW-28).



ADAMS RITE
MANUFACTURING CO.

260 Santa Fe Street
Pomona, California 91767
(800) 872-3267 Fax: (800) 232-7329
www.adamsrite.com



MS1850SN-050 ANSI Size Deadbolt

DIMENSIONS

INCHES
MILLIMETERS

Nominal, subject to tolerance extremes.

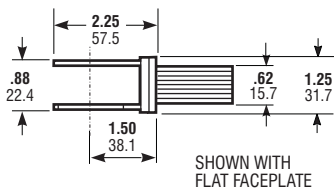

SHOWN WITH
FLAT FACEPLATE

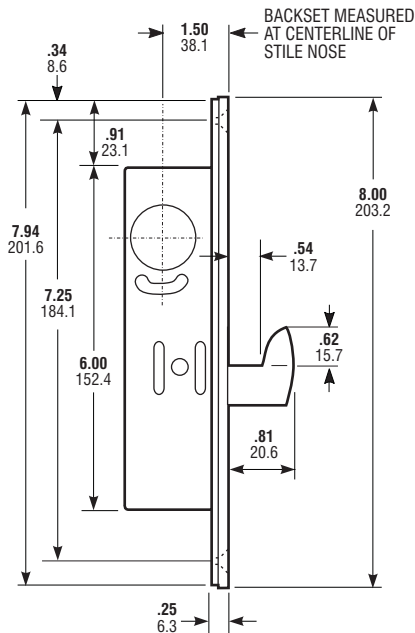

BACKSET MEASURED
AT CENTERLINE OF
STILE NOSE

ARMORED FACEPLATE 1-1/4" x 8"	
FLAT	MS1850SN-050
RADIUS	MS1851SN-050
LH BEVEL	MS1852SN-055
RH BEVEL	MS1852SN-056

HOW BACKSET IS MEASURED

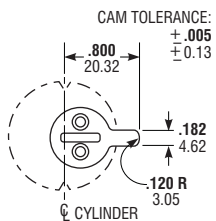
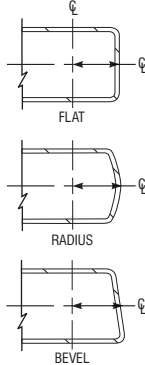

Cylinder Cam

MS1850SN-050 Series locks are operable by any standard 1-5/32" diameter mortise cylinder with special MS® cam dimensioned as shown. Cylinders with MS® cams can be readily obtained from most cylinder manufacturers. See page SW-28 for cylinder make and trim ring information.

HOW TO ORDER

Specify quantity and the following information.
Order related hardware separately.

Faceplate Shape

- 1850SN** Flat
- 1851SN** Radius
- 1852SN** Bevel

Handing

- 455** LH or RHR
- 456** RH or LHR
- 450** Non-Handed*

MS 1850SN - 450 - 628

Finish

- 628** Clear Anodized
- 313** Dark Bronze Anod.
- 335** Black Anodized

*Any flat or radius face.

Consult factory about special finishes.

INSTALLATION

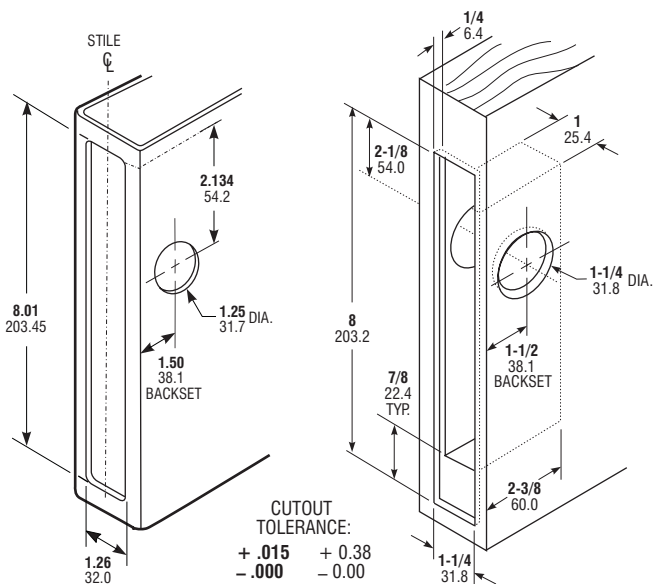

Stile Preparation

Wood Door Preparation

CUTOUT TOLERANCE:
+ .015 + 0.38
- .000 - 0.00

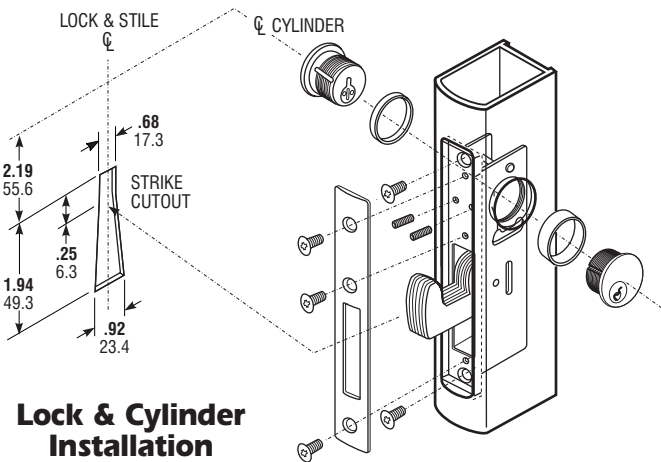

Lock & Cylinder Installation

OPTIONS

Choice of faceplate finish and shape (flat, radiused or bevel cross-section to match door nose) must be specified.

STANDARD PACKAGE

Individually boxed with machine screws for mounting. Cylinders and/or thumbturn available at extra cost. Shipping weight: 1-1/2 lbs. Also available in a 20 unit pack for volume users.