

## Two-Point Deadbolt for Wood Doors

### MS1837

ANSI/BHMA Type E8241 (Grade 1)

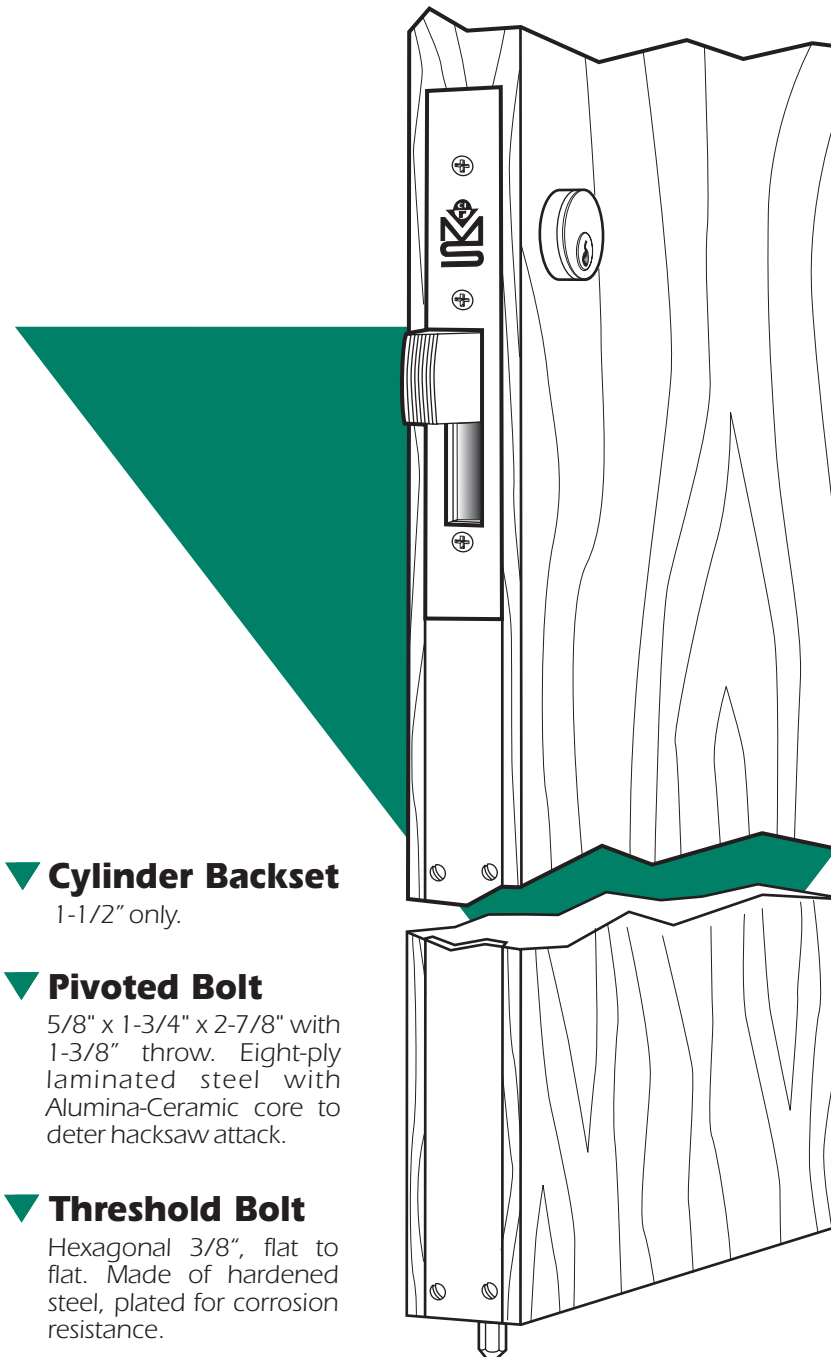

▼ **Cylinder Backset**  
1-1/2" only.

▼ **Pivoted Bolt**  
5/8" x 1-3/4" x 2-7/8" with  
1-3/8" throw. Eight-ply  
laminated steel with  
Alumina-Ceramic core to  
deter hacksaw attack.

▼ **Threshold Bolt**  
Hexagonal 3/8", flat to  
flat. Made of hardened  
steel, plated for corrosion  
resistance.

▼ **Function**  
Maximum Security for wood door pairs by a single turn of a key is provided with the MS1837. Dropping a hardened steel hexbolt into the threshold and pivoting the massive MS® bolt into the opposite leaf, the MS1837 eliminates inconvenient and sometimes forgotten flushbolts in the inactive leaf.

▼ **Case**  
Steel with corrosion-resistant  
plating. 1" x 6" x 2-3/16".

▼ **Cylinder Height**  
36" standard. Other heights available on  
special order.

▼ **Armored Faceplate**  
Flat, two-piece plate extends to bottom of door.  
Standard finish is US28 (628) Clear Anodized.  
Contact factory for additional finishes.

▼ **Strike**  
For MS® bolt, a strike plate with dust box is  
furnished. (See 4001-011 on page SW-14).  
Threshold bolt strike can be a 1/2" diameter  
hole in metal threshold or, if threshold is wood,  
4005 strike is available as an option.

▼ **Operation**  
360° turn of key or thumbturn throws counterbalanced bolt  
into opposite door and drop bolt into threshold. Key can be  
removed only when bolts are in a positively locked or  
unlocked position. Lock accepts any standard 1-5/32"  
mortise cylinder from either or both sides. Cylinder must  
have MS® cam. (See page SW-28.)



# MS1837 Two-Point Deadbolt

## for Wood Doors

### DIMENSIONS

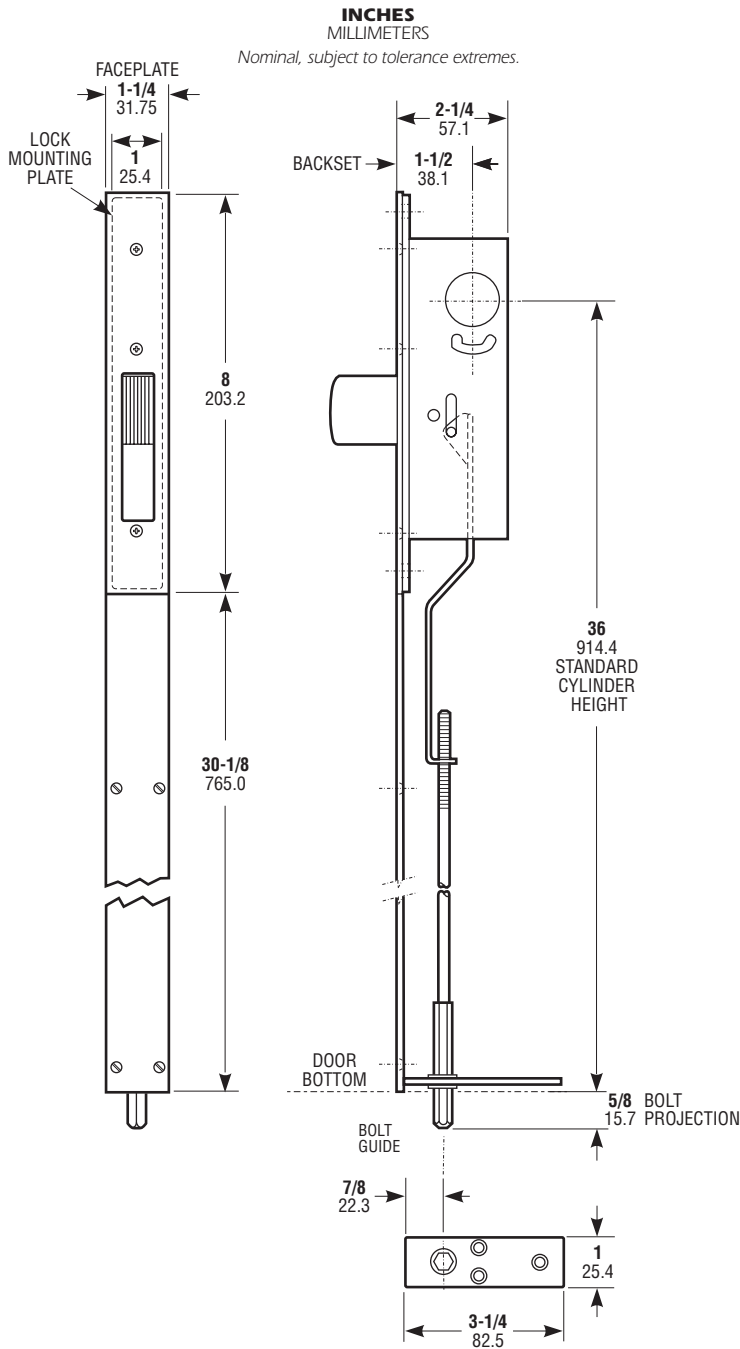

### HOW TO ORDER

Specify quantity and the following information.  
Order related hardware separately.

# MS1837

If Cylinder Height other than 36" is required, specify exact height from bottom of door to cylinder center.

Specify 4005 Strike separately if required for threshold bolt.

Contact factory for available finishes.

### INSTALLATION

INSTALL ADAPTOR ARM IN LOCK FROM REAR WITH BOLT RETRACTED AS SHOWN. DRIVE PIN THROUGH SLOTS IN LOCK SIDE PLATES, PASSING THROUGH HOLE IN THE ADAPTOR ARM.

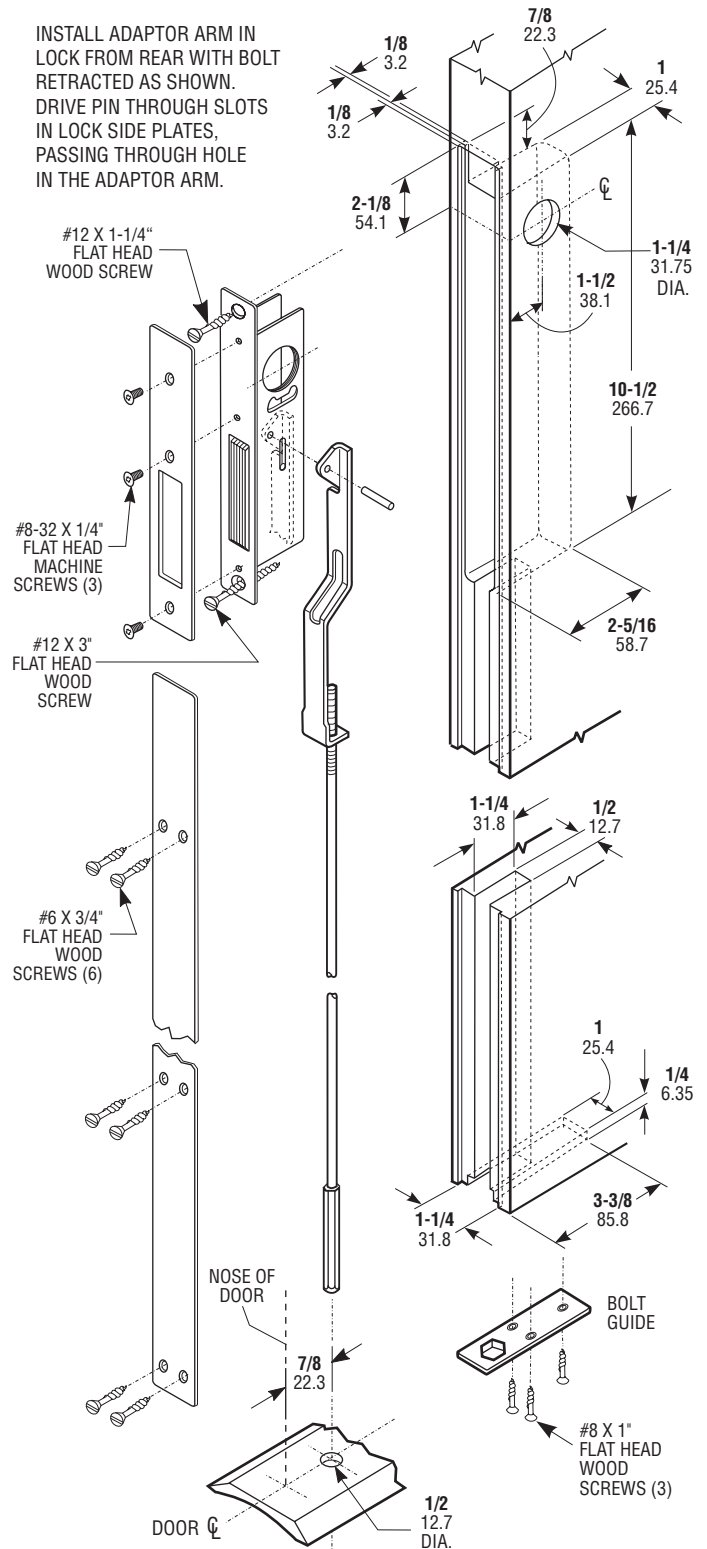

### STANDARD PACKAGE

Basic MS® lock individually boxed with mounting screws. Hexbolt and rod packed separately with face extension plate, screws, bottom bolt guide and attachment pin. Cylinders and/or thumbturn available at extra cost. Shipping weight: 3 lbs.