

QUATTROCODE

Operating manual

D415175XA

vers. **2.0**



(c) 1999 SILCA S.p.A. - Vittorio Veneto

All rights reserved. No part of this publication may be reproduced or used in any form or by any means (photocopying, microfilm or other) without the permission of SILCA S.p.A.

Second edition march 1999

Printed in Vittorio Veneto

by SILCA S.p.A.

Via Podgora, 20 (Z.I.)

31029 VITTORIO VENETO (TV)

Italy.

(*) IBM is a registered trade mark of the International Business Machine Corporation.

(**) Waste is defined as any substance or object deriving from human activity or natural cycles which has been thrown away or will inevitably be thrown away.

INDEX

	CONSULTING THE MANUAL	5
	GENERAL	6
	PROTECTION AND SAFETY PRECAUTIONS FOR THE OPERATOR	7
1	GENERAL DESCRIPTION	8
	1.1 Main operating features	8
	1.2 Safety devices	9
	1.3 Technical data	11
2	TRANSPORT	12
	2.1 Packing	12
	2.2 Unpacking	13
	2.3 Handling the machine	13
3	INSTALLATION AND SETTING UP	14
	3.1 Checking for damage	14
	3.2 Positioning	14
	3.3 Graphics	15
	3.4 Installation of the Silca Quattrocode Program software	15
	3.5 Starting the Silca Quattrocode Program	15
4	MACHINE REGULATION	16
	4.1 Machine keypad and functions of keys	16
	4.2 Decoder pocket	17
	4.3 Cutting tool replacement	18
	4.4 Use of the clamp	19
	4.5 Fitting the clamp to the machine	20
	4.6 Turning the mobile jaw (P1) on clamp 'J1'	20
	4.7 Key stop	21
	4.8 Anti-tilting device	22
	4.9 Clamp detection	23
	4.10 Clamp calibration	23
5	DECODING KEYS	25
	5.1 Decoding	25
6	KEY CUTTING	26
	6.1 Data storage in the machine memory	26
	6.2 Code selection	26
7	TEST FUNCTIONS	27
	7.1 Sensor test	27
	7.2 Photocell test	30
	7.3 Motor tests	31
	7.4 Display and keypad test	33

8	CLEANING	34
9	MAINTENANCE	35
9.1	Trouble shooting	35
9.2	Maintenance operations	36
9.3	Belt replacement and tension	36
9.4	Checking and replacing the fuses	37
9.5	Replacing the UNIPOW 50 Supply circuit board	40
9.6	Replacing the 1st ST2DRV module - X and Y axes step motors	41
9.7	Replacing the 2nd ST2DRV module - Z and A axes step motors	42
9.8	Replacing the 3rd ST2DRV module - B axis step motor	43
9.9	Replacing the CPU module	44
9.10	Replacing the inlet/outlet modules and terminal panel	45
9.11	Replacing the keypad/display	46
9.12	Replacing the electronic rack	47
9.13	Access to the motor compartment	49
9.14	Access to the electrical parts in the base	50
10	DECOMMISSIONING	51
11	AFTER-SALES SERVICE	52
11.1	How to apply for assistance	52

CONSULTING THE MANUAL

This manual has been produced to serve as a guide for users of an electronic key-cutting machine
 The contents of the manual are divided into sections relating to:

	chapter
• Machine description	1
• Transport and installation	2-3
• Regulation and use	4-5-6
• Tests and maintenance	7-8-9

Technical terms

Common technical terms are used in this manual. To assist those with little experience of cutting keys, below is an illustration of the terms most frequently used.

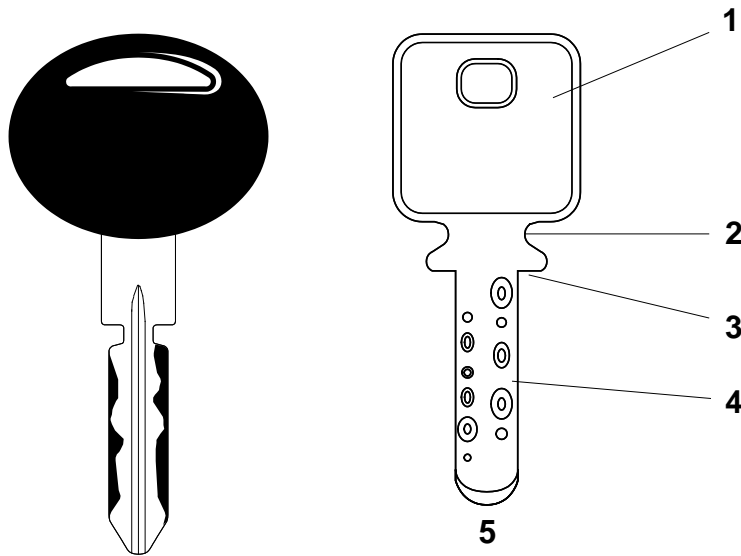

Fig. 1

- 1) Head
- 2) Neck
- 3) Shoulder
- 4) Stem
- 5) Tip

GENERAL

QUATTROCODE has been designed according to the principles of the Machine Directives. From the design stage risks for the operator have been eliminated in all areas: transport, regulation, cutting and maintenance.

The material used in the manufacture of this machine and the components employed during use are not dangerous and assure that Quattrocode complies with the Machine Directives.

Use

Quattrocode has been designed for the copying of keys. It must be installed and used in the way laid down by the manufacturer. If the machine is used differently or for purposes different from those described in this manual, the customer will forego any rights he may have over SILCA S.p.A. Furthermore, unforeseen danger to the operator or any third parties may arise from incorrect use of the machine.

Improper use

Negligence in the use of the machine or failure on the part of the operator to observe the instructions given in this manual are not covered by the guarantee and the manufacturer declines all responsibility in such cases.

It is therefore indispensable to read the operating manual carefully in order to make the best use of the key-cutting machine and benefit from its potential.

Further risks

WARNING: *during cutting operations there is a risk of hands being crushed. To avoid this, keep hands well away from the area circled in the drawing.*

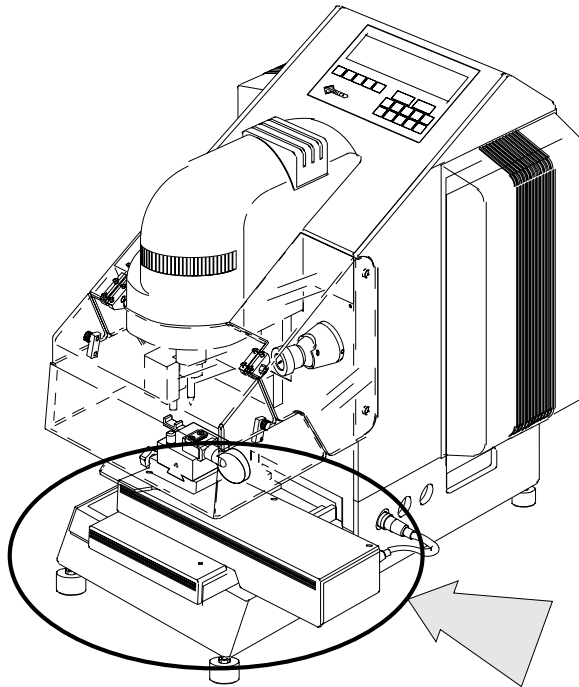

PROTECTION AND SAFETY PRECAUTIONS FOR THE OPERATOR

The Quattrocode fully complies with the Machine Directives. The operations for which it has been designed are easily carried out at no risk to the operator.

The adoption of general safety precautions and observation of the instructions provided by the manufacturer in this manual eliminate all human error, unless deliberate.

The Quattrocode is designed with features which make it completely safe in all its parts.

Characteristics

- **Power supply**

Quattrocode must be provided with electricity having the same voltage as that shown on the rating plate, supplied through an earthed socket and differential switch.

- **Start-up**

The machine is started up by means of a master switch placed on the back.

- **Maintenance**

The operations to regulate, service, repair and clean the machine have been devised in the simplest and safest way possible. There is no danger of removable parts being replaced wrongly or unsafely.

- **Machine identification**

The machine is provided with an identification label which shows the serial number (fig. 2).

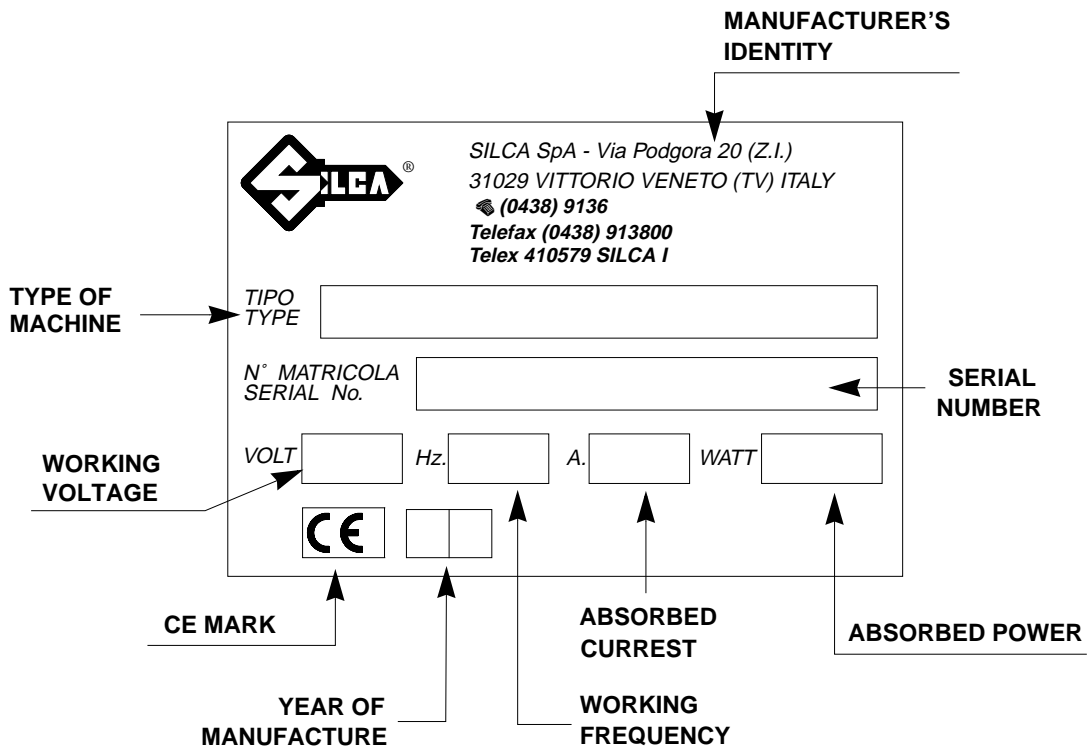

Fig. 2

1 GENERAL DESCRIPTION

Quattrocode is an electronic machine operating on three controlled axes. Meticulously designed down to the finest details, it combines operating speed with ease of use and high precision results. The machine operates linked to a personal computer. The operating programs are set up with the machine keypad.



Fig. 3

1.1 Main operating features

- **Movements**

Movement of the three axes (x-y-z) operates with pre-loaded ball screws, driven by step motors on ground roller guides.

- **J1 clamp**

Standard clamp designed to house almost all dimple or laser keys.

- **Cutting shaft**

Comprises an electrically controlled tool-locking system.

- **Cutting tool**

An easily replaced cutting tool (HSS or hard metal) with resistance and cutting properties suitable for the type of work and speed of rotation.

- **Display**

Alphanumeric display with scrolling text on 2 lines of 12 characters each, placed on top of the machine.

Its design and position ensure practical, easy use.

1.2 Safety devices

The transparent protective shield is designed to cover and render as safe as possible the working parts of the machine.

The shield (D) must be raised to fit keys for cutting or carry out any other operations on the machine. Raising of the shield is controlled by a microswitch (D1) (fig. 5, page 10) and disactivates the working and movement functions, including the cutting tool. The fact that the shield is not down is indicated by a message on the machine display.

To re-activate the work cycle, place the shield in its initial position and press the START button on the machine keypad.

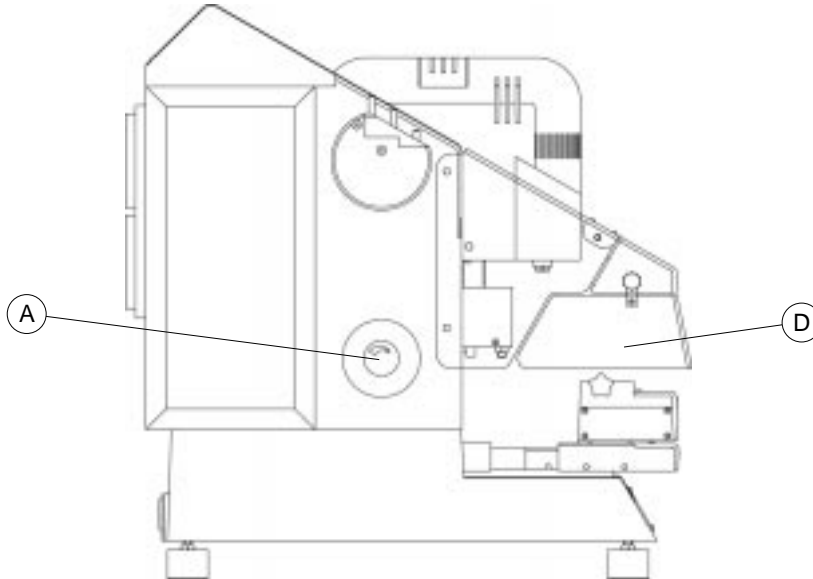

Fig. 4

- **Emergency stop**

The machine can be cut off by means of the red emergency button (A) placed on the left. When this button is pressed the machine stops immediately when there is a serious malfunction or risk of danger for the operator. After elimination of the cause of the emergency, turn the button 45° clockwise.

N.B.: it is the operator's responsibility to keep clear the area around the emergency button so that it can be reached rapidly.

Main working parts

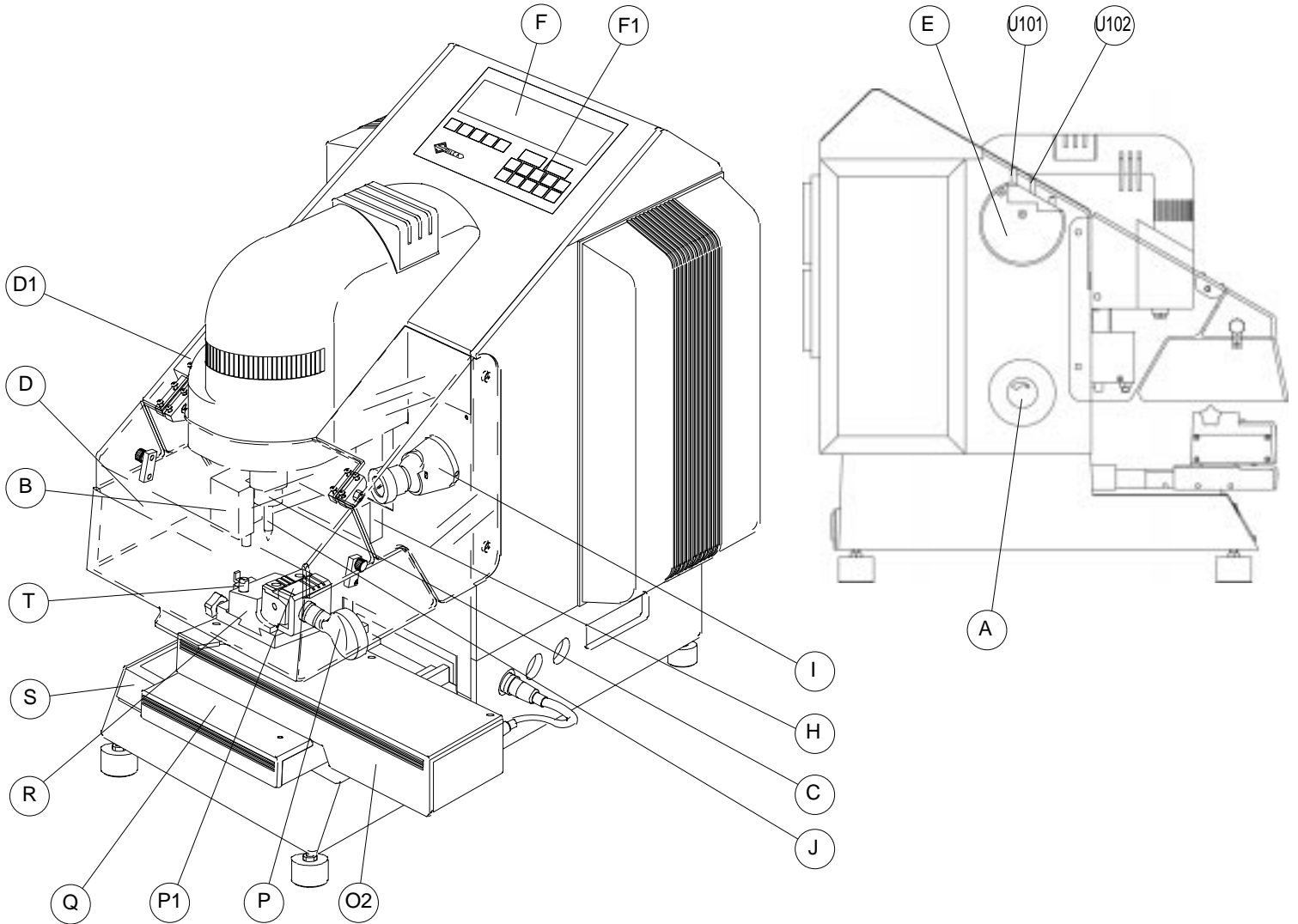
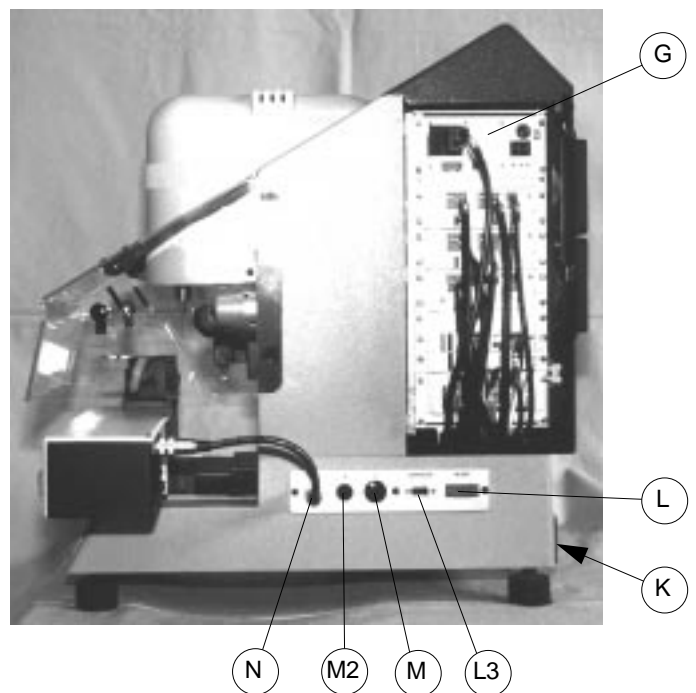

Fig. 5

- A emergency button
- B clamp detector sensor
- C spindle
- D mobile protective shield
- D1 safety microswitch
- E decoder holder
- F display
- F1 keypad
- G electronic rack
- H Z axis carriage
- I halogen lamp
- J tool
- K start switch
- L 2nd IN-OUT serial port (various)
- L3 1st serial port (computer)
- M switch socket (for future use)
- M2 special clamp connector
- N X axis connector
- O2 X axis carriage
- P knob
- P1 rotating jaw
- Q Y axis carriage
- R J1 basic clamp
- S metal chip tray
- T Z axis setting plate
- U101 LASER key decoder
- U102 Dimple key decoder



1.3 Technical data

POWER SUPPLY:	Single phase 220V (110V - 60 Hz)
MAX. ABSORBED POWER:	1.5 Amp (350 W) (110V: 3 Amp (350W))
CUTTER MOTOR:	Two-speed single phase
CUTTING TOOLS:	in HSS (high speed steel) or Widia (hard metal)
CUTTER SPEED:	6000 rpm (+/- 10%) (HSS) / 12000 rpm (+/- 10%) W (hard metal)
MOVEMENTS:	On three axes with preloaded recirculating ball screws activated by step motors on ground roller guides. Cutting tool spindle released and locked by a step motor.
CLAMP:	Universal 'J1' (standard) for key lock grip, reversible mobile jaw for locking special 'Z' profile Mercedes keys.
RUNS:	X axis: 55 mm Y axis: 55 mm Z axis: 55 mm
DIMENSIONS:	Width 390 mm / depth 530 mm / height 570 mm
MASS:	60 kg.
NOISE RATING:	Noise pressure: Lp (A) = 79.16 dB (A)

Personal Computer

The personal computer (not included) to be used for transmission of the operating program to the Quattrocode should have the following minimum specifications:

- Model: IBM¹ or 100% IBM compatible - Microprocessor 80286 at 12 Mhz or over.
- Operating system: MS-DOS version 3.30 or later
- RAM: minimum 640 Kb
- Floppy disk unit: 1 x 1.2 Mega (5
- Minimum hard disk capacity: 5 MB
- Serial port: RS-232
- Parallel port (printer): Standard
- Video screen: VGA Monochrome

A Pentium 90Mhz microprocessor is preferable

- Version MS-DOS 6.0
- Video VGA-Colour (High Resolution Graphics)

N.B.: proper operation of the program and data transmission from the personal computer to the Quattrocode key-cutting machine cannot be guaranteed unless the personal computer 'BIOS' is 100% IBM compatible.

Accessories provided

Quattrocode is provided with a set of accessories for use and maintenance of the machine (tools, hex. wrenches, fuses, etc.), found in the tool box provided.

Tool box	Locking bar	Screwdriver handle
13 mm wrench	Gauging template and pin	2 mm socket head
10 mm wrench	A - 4 Amp. fuse - rapid	2.5 mm socket head
7-8 mm wrench	B - 1 Amp. fuse - delayed	3 mm socket head
1.5 mm allen wrench	C - D - E - 4 Amp. fuse- delayed	4 mm socket head
5 mm allen wrench	F - 1.6 Amp. fuse - delayed	Flat screwdriver
6 mm allen wrench	G - 3.15 Amp. fuse - rapid	Star screwdriver
Elbowed wrench	3 m serial cable 25/9 pin	
Straight brush	Jumper cable	

2 TRANSPORT

The key-cutting machines are easy to transport and not dangerous to handle. The packed machine can be handled manually by two people.

2.1 Packing

The packing for the Quattrocode guarantees sure and safe transport for the machine and all its component parts. It comprises a pallet base (b), to which the machine is anchored, and a cardboard cover (a).

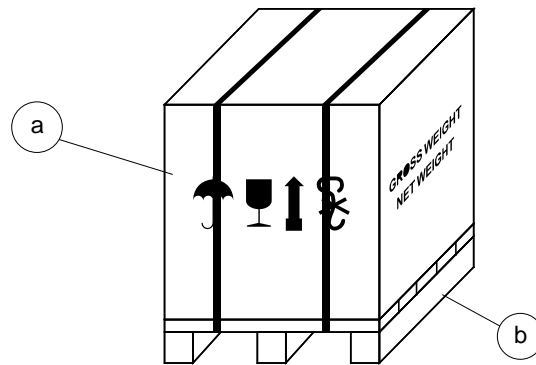

Fig. 6

The machine is attached to the base by means of screw-down brackets which hold it in place during transport, avoiding damage, especially to the protective shield. The sealed cardboard cover is attached to the pallet by means of two straps which hold it securely in place. Symbols on the cardboard cover show the ideal conditions for transport.



To avoid knocks which could damage the Quattrocode, we recommend using the original packing every time the machine is transported, securing it to the base with the special brackets.

2.2 Unpacking

To remove the machine from the packing:

- 1) cut the straps with scissors and remove them.
- 2) raise the top of the cardboard cover.
- 3) unscrew the 3 screws (c) securing the front bracket to the pallet (fig. 7).
- 4) unscrew the 3 screws (c) securing the rear bracket to the pallet (fig. 7).
- 5) use the wrench provided to loosen the nuts on the rear feet by a couple of turns.
- 6) remove the metal brackets (fig. 7).
- 7) check that the packing box contains:
 - 1 Quattrocode key-cutting machine
 - 1 set o documents, including: Operating Manual, QUATTROCODE PROGRAM manual, spare parts list and guarantee
 - 1 power supply cable
 - 1 tool box
- 8) keep the packing to use every time the machine is transported.

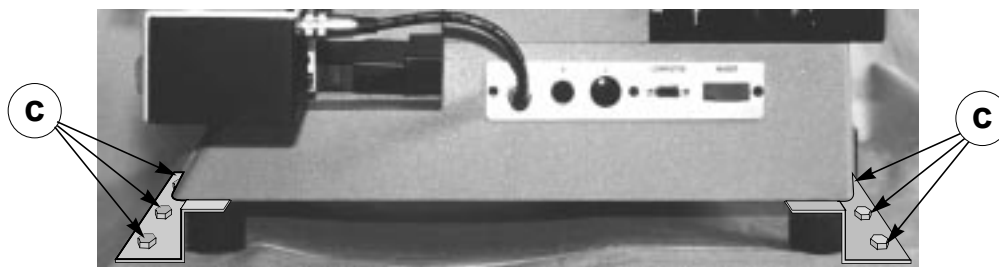

Fig. 7

2.3 Handling the machine

When the Quattrocode has been unpacked, place it directly on its workbench. This should be done by two people, holding the metal base firmly to lift the machine.

3 INSTALLATION AND SETTING UP

Installation can be carried out by the purchaser and does not require any special skills. The key-cutting machine is supplied ready for use and assembly is not necessary. However, some checks and preparation for use need to be carried out.

Environmental conditions

To ensure that the best use is made of the key-cutting machine, certain parameters must be borne in mind: damp, badly ventilated sites should be avoided. The ideal conditions for the machine are: temperature between 0 and 40°C, relative humidity approx. 60%.

3.1 Checking for damage

The Quattrocode is solid and will not normally damage if transport, unpacking and installation have all been carried out according to the instructions in this manual.

However, it is always advisable to check that the machine has not suffered any damage.

3.2 Positioning

- Place the machine on a horizontal surface, solid enough to take the weight (60 kg). The workbench should ideally be at a height of approx. 100 cm, which ensures easy access to the working parts. Leave at least 30 cm clearance behind the machine to provide ventilation and 30 cm on both sides.
- Connect the power supply cable and the serial cable to their sockets.

WARNING: ensure that the machine voltage is the same as that of the mains, which must be properly earthed and provided with a differential switch.

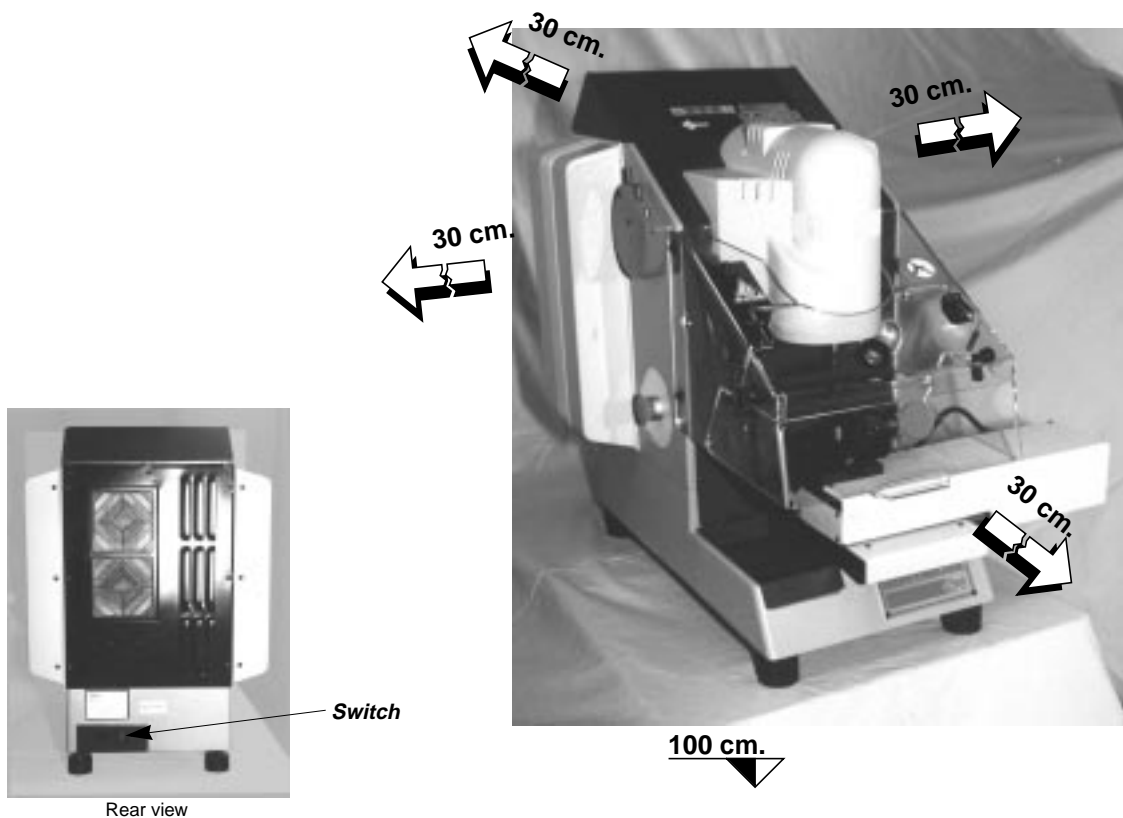

Fig. 8

The machine needs only one operator, who has the following controls at his/her disposal (fig. 5, page 10):

- motor start switch (K), placed on the back of the key-cutting machine;
- key positioning clamp (R);
- control keypad (F1);
- emergency button (A).

3.3 Graphics

Two adhesive warning and instructions labels are attached to the plexiglass shield (fig. 9). These must not be removed.

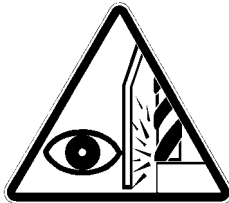

Danger to eyes!



*Do not use compressed air
for cleaning*

Fig. 9

3.4 Installation of the Silca Quattrocode Program software

- Connect the personal computer and QUATTROCODE with the serial cable provided. Make the connection between the personal computer serial port and the connector (L3) on the Quattrocode (fig. 10).
- Turn on the Quattrocode and the computer.
- Install the QUATTROCODE PROGRAM software on the PC. To do so consult the manual provided with the software package for the installation and use of the "SILCA QUATTROCODE PROGRAM".
- Ensure that the U101 - U102 decoders are housed in the special decoder pocket on the left-hand side of the machine.

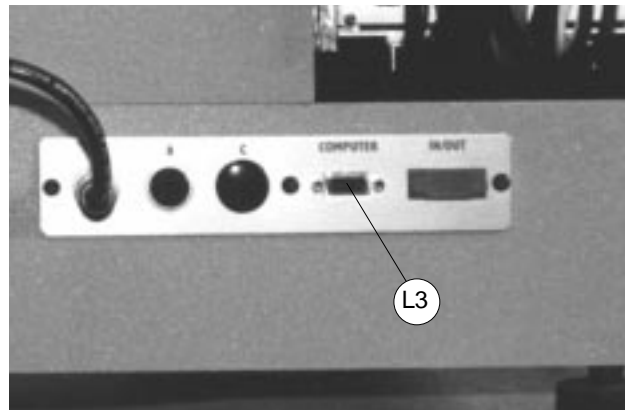

Fig. 10

3.5 Starting the Silca Quattrocode Program

When the SILCA QUATTROCODE PROGRAM has been installed on your PC, to work with the program enter the following command:

<QCODE> + ENTER

The SILCA logo will appear, followed by the main menu.

4 MACHINE REGULATION

4.1 Machine keypad and functions of keys

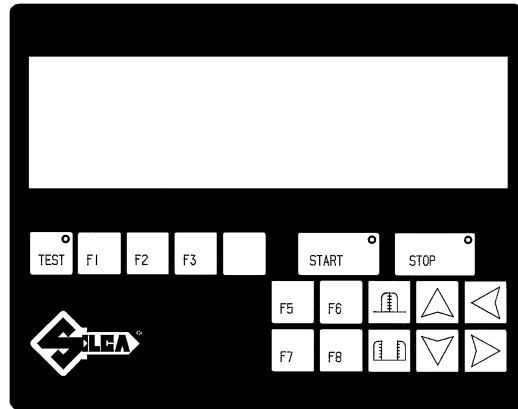

Fig. 11

The keypad incorporated in the Quattrocode, illustrated in fig. 11, enables the operator to use the machine rapidly and easily once the work program has been transmitted by the PC. Only the keys necessary for the cycle in progress (except the STOP button, which is always active) are constantly enabled, e.g. when the cutting tool is being changed only the keys for releasing and locking the spindle and the START button are active; all the other keys are excluded, even if pressed.



striking this key starts the machine TEST function (indicated by the illumination of the red led in the corner of the key).



keys reserved for future functions.



spindle release (active only when the tool change message is screened).



spindle lock (active only when the tool change message is screened).



enables forward scrolling on the display of the key queue transmitted by the PC.



enables backward scrolling on the display of the key queue transmitted by the PC.



- during the TEST moves the step motors in one direction
- during work operations starts scrolling of the writing on the display (if it comprises more than the 12 characters shown)



- during the TEST moves the step motors in the other direction
- during work operations stops scrolling of the writing on the display.



- starts the cutting operation (by code) on the key selected from those on the display.
- re-starts the cutting operation after interruption to change the cutting tool or turn the key.
- starts the cutting tool TEST function.

Acts as function key to enable an operation transmitted by the PC or the machine
The START button has a green led which illuminates to indicate work in progress.



stops the operation in progress at any given moment, returning the axes to the idle position.



switches the lamp on or off.

4.2 Decoder pocket

A special device (E) is installed on the left-hand side of the machine to house the decoders when they are not in use (fig. 12).

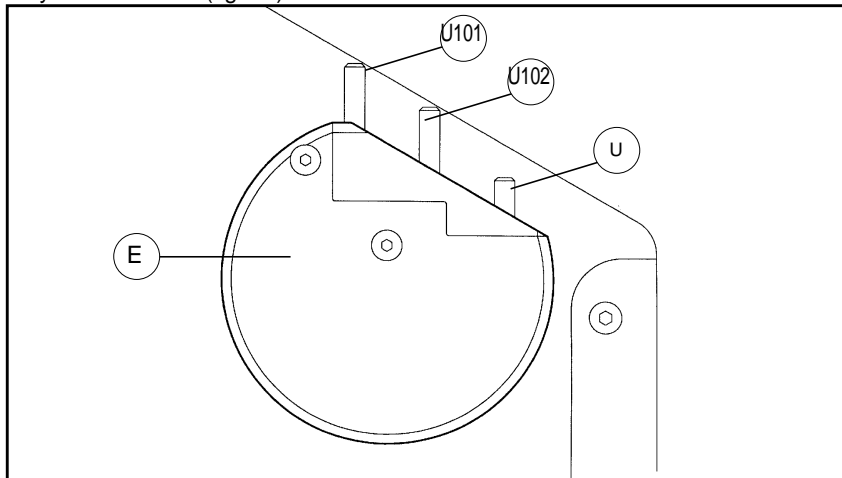

Fig. 12

The decoders provided are:

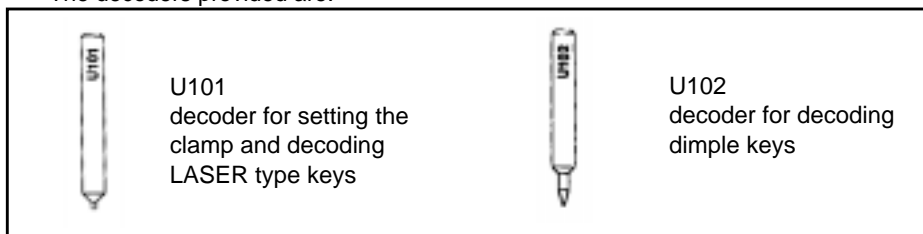

Fig. 13

The device is designed to house a third decoder (U103 - not provided), whose place is occupied by an imitation decoder (U) which should never be removed.

The decoders must be replaced in the device after use.

Before starting to cut a key, the machine checks that all the housings are occupied. If not, the machine stops and shows the following message on the display:

<DECODER WRONGLY
POSITIONED>

WARNING: *this safety system ensures that the cutting tool is not used instead of the decoder, or vice versa.*

4.3 Cutting tool replacement

The cutting tool can be fitted or replaced only at one point in the work process, when the display shows, i.g.:

<INSTALL CUTTING TOOL H101>

WARNING: *to describe cutting tool replacement, tool 101 is used as an example. For the other cutting tools, carry out the same sequence with the tool required.*

To remove a decoder or cutting tool from the spindle, proceed as follows:

- Raise the protective shield (D);
- with one hand hold the cutting tool or decoder to be removed;



Press the spindle release key with the other hand;

- remove the cutting tool. The decoder must be replaced in its housing on the decoder pocket (E) on the machine (fig. 12, page 17), whereas the cutting tool must be placed in its housing on the tool board provided.

To install a cutting tool, proceed as follows:

- Raise the protective shield (D);



release the spindle, if necessary, by pressing the spindle release key;

- fit the cutting tool into the spindle, pushing all the way in;



hold the cutting tool in place with one hand and with the other press the spindle locking key.

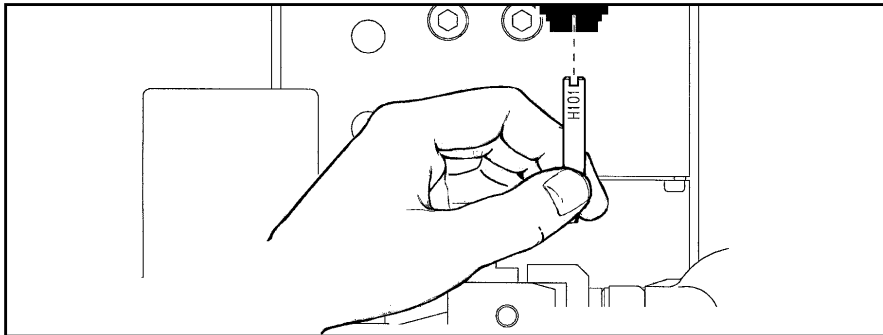

Fig. 14

WARNING: *when an operation is begun by pressing START (cutting), the situations described below may occur:*

1) Spindle locked with tool missing:

the machine seeks the setting for the Z axis by moving the spindle over the special plate on the clamp. As this causes the spindle to come into close proximity (over the safety measurement) to the plate, the cycle in progress is stopped, the spindle is moved back to its initial position and the display shows the message:

<INSTALL H101>

2) Spindle released (tool missing)

the machine fails to start the cutting cycle. The display shows the same message:

<INSTALL H101>

WARNING: *the type of cutting tool to install may be identified by the letter H (HSS) or W (hard metal).*

This means that the QUATTROCODE will automatically use cutting speed 1 (HSS) or 2 (W - hard metal) (see Ch. 'Accessories' in the SILCA QUATTROCODE PROGRAM manual).

4.4 Use of the clamp

The machine is supplied with the 'J1' standard clamp illustrated in fig. 15.

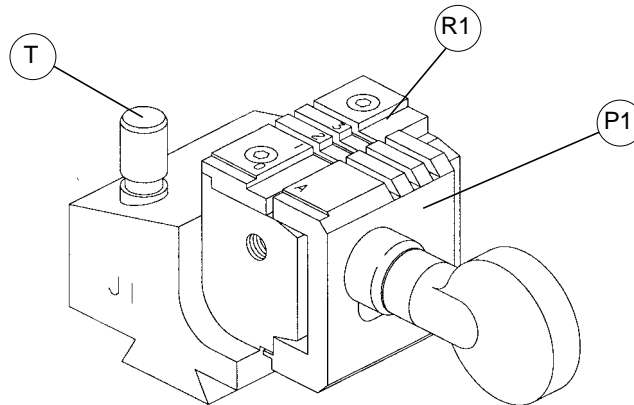

Fig. 15

As shown in fig. 15, the 'J1' clamp has a fixed plate (R1) on top and a mobile jaw (P1), both of which can be replaced when worn.

The clamp also has a setting plate (T) for the Z axis (sprung), over which the cutting tool zeroes before starting cutting operations on a new key. The plate is sprung to avoid microfractures when the cutting tool makes contact with it.

WARNING: *to ensure that the Z axis works accurately, keep the setting plate (T) perfectly clean by brushing any metal chips off regularly, using the brush provided.*

WARNING: *do not exert excessive pressure to lock the key in the jaws. Turning the knob approximately 70° (clockwise) when the jaws start to grip the key is sufficient (fig. 16). It is also important to ensure that the key lies absolutely flat in the jaw during locking so that it cannot bend, twist or rest unevenly on the plate (fig. 16).*

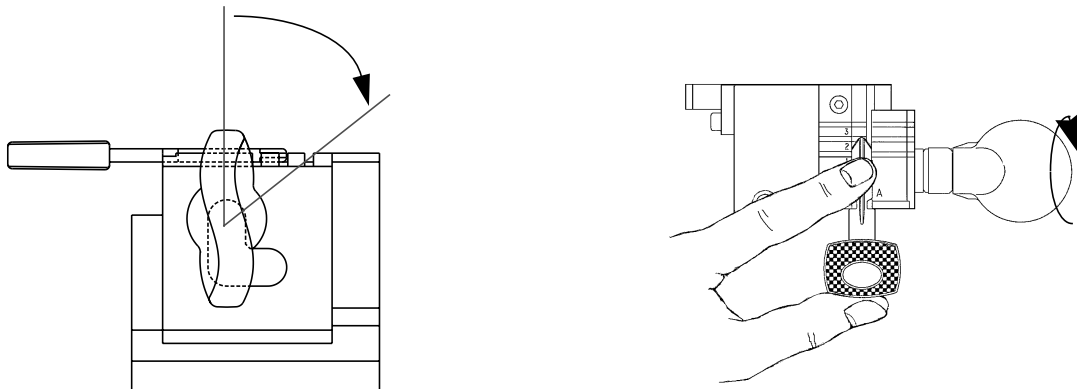

Fig. 16

4.5 Fitting the clamp to the machine

Fit the clamp into the carriage dovetail, push all the way in and lock by means of the knob (P2) (fig. 17).

Although Quattrocode is designed to take up to 16 different clamps (identified progressively from "J1" to "J16") the instructions refer only to the clamp provided (J1). The other clamps are all provided with their own instructions.

4.6 Turning the mobile jaw (P1) on clamp 'J1'

Clamp "J1" is supplied with mobile jaws (P1) which can be reversed (sides A and B) to facilitate locking (on side B) of special profile Mercedes keys (corresponding to Silca articles HU41P, HU41AP, HU44AP, HU55P, HU61AP) without the need for additional adapters (fig. 17). When side B is in use the display shows a message.

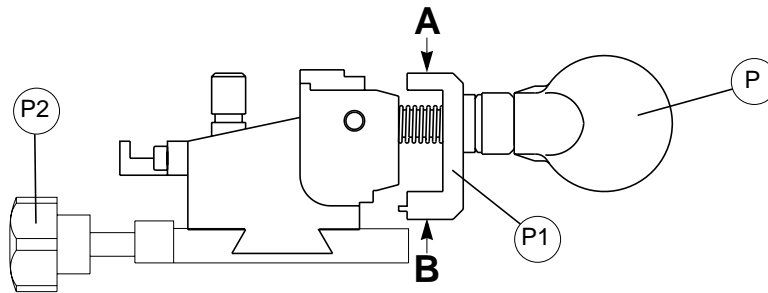

Fig. 17

To take the jaw (P1) into position B, proceed as described below:

- 1) move the jaw upwards then to the left (fig. 18-A);
- 2) from this position, turn the jaw 90° to the left (fig. 18-B);
- 3) raise the jaw as shown in fig. 18-C and turn 90° to the left (fig. 18-D);
- 4) move the jaw to the right (fig. 18-E).

To take the jaw to its initial position (fig. 17), carry out the same process in reverse order.

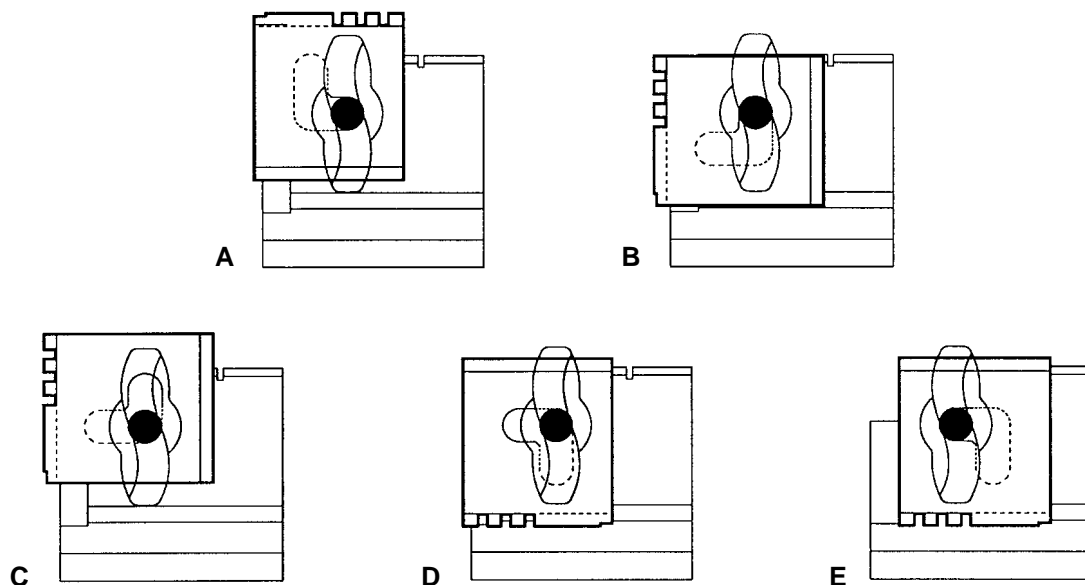

Fig. 18

4.7 Key stop

Clamp 'J1' is designed to house high security keys with different characteristics, i.e. keys with shoulders, or keys without which use the tip as a stop.

The former type (with shoulders) are placed in the jaw with the stop against the clamp (stop "0") (fig. 19). The latter (without shoulders) are placed in position on one of the grooves (1 - 2 - 3), as shown on the display, according to the key involved.

A bar (V) (fig. 19) is also provided with the clamp to serve as a stop for the key tip.

When the key is locked in the jaw, remove the bar (V) before starting the machine.

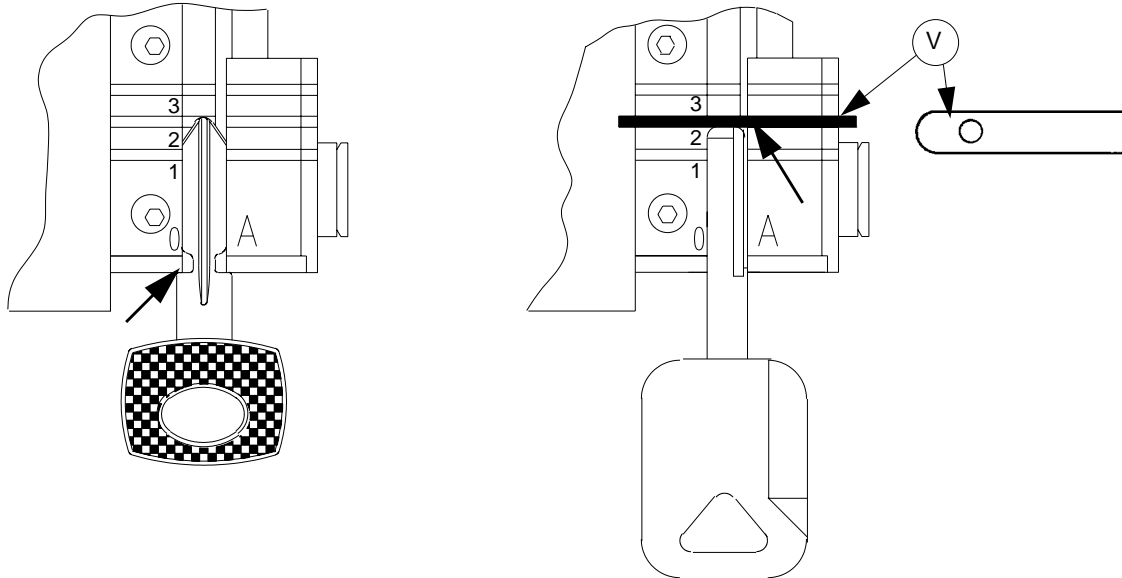

Fig. 19

4.8 Anti-tilting device

The machine is provided with a device (X) (fig. 20) to use with keys which are difficult for the jaws to grip because of the dimensions of the blade and profile (see art. Silca HU56RP for Volvo, fig. 21). The device is installed in the threaded hole on the front of the "J1" clamp. Use the locking knob (X1) to take it up to the clamp, without securing; **the knob (X1) will be tightened only after the key has been locked into the jaw in the way described below:**

- hold the device up against the front of the clamp and by means of the knob (X2) grip the neck of the key in the seat provided. The locking operation is self-centring so that there is no danger of the key being moved once it is locked into the jaw. Secure the device to the clamp by means of the locking knob (X1).

WARNING: ensure that the locking knob (X1) does not protrude above the upper edge of the clamp when it has been locked.

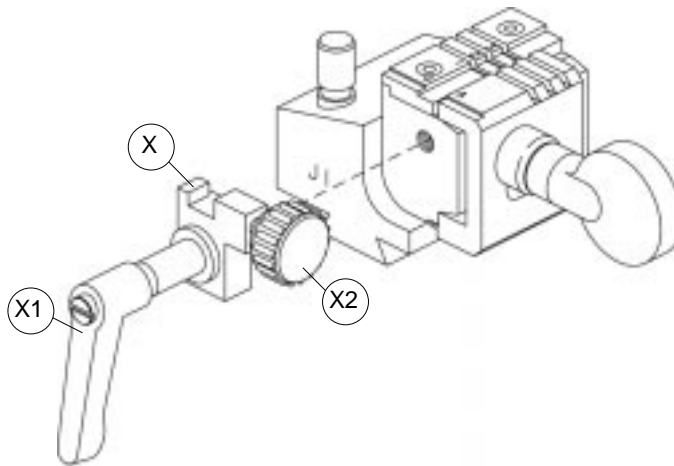

Fig. 20

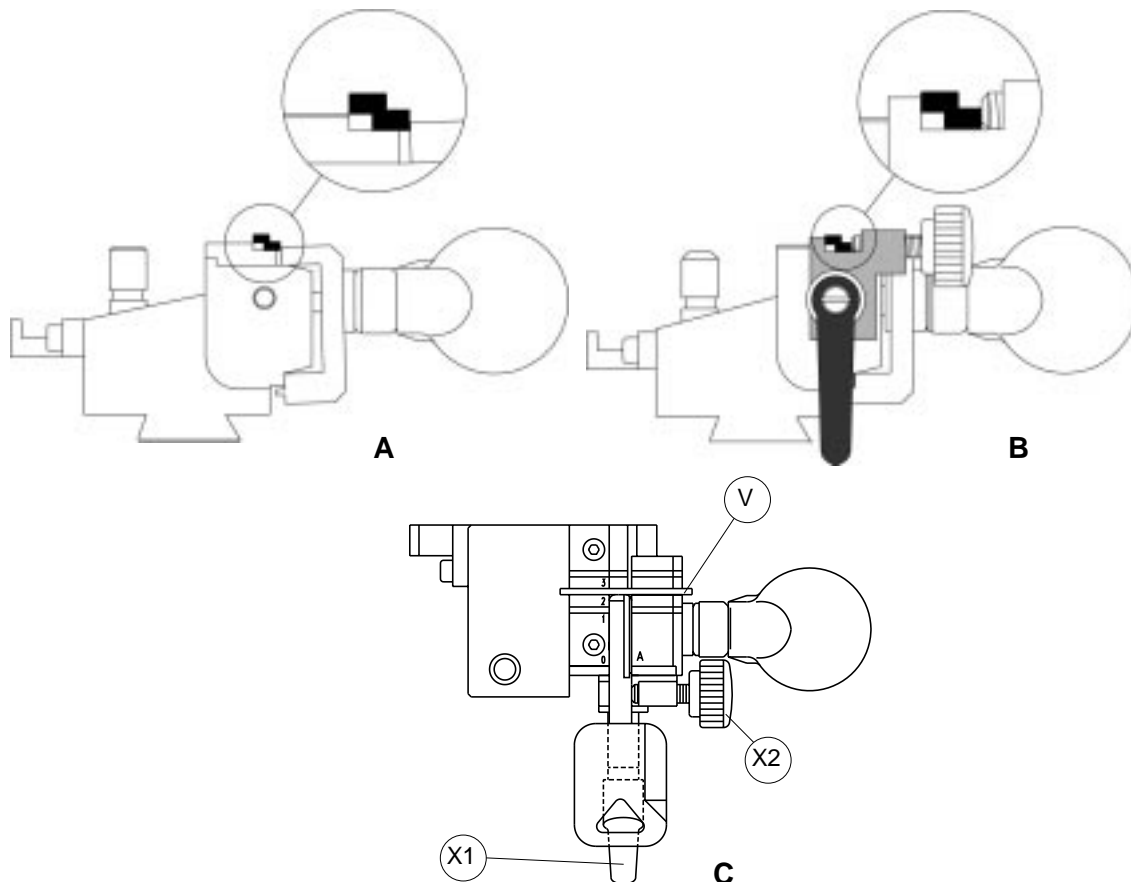

Fig. 21

4.9 Clamp detection

Each clamp is provided with a coded bar (X3) which enables the machine to detect it automatically (fig. 22). The coded bar is read by a special proximity sensor (X4) (fig. 22) at the beginning of every cutting cycle. If the clamp installed is not the one required (on the display: clamp = J...), the machine will return to its position at the beginning of the cycle while the display shows the message:

< INSTALL CLAMP "J1" >

To re-start the clamp detection process, strike START on the keypad.

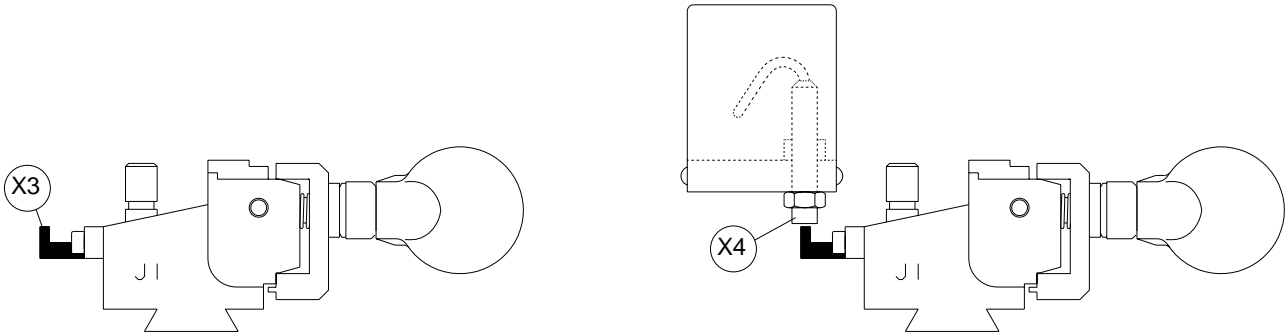

Fig. 22

4.10 Clamp calibration

Set-up must be carried out whenever:

- one of the proximity sensors is replaced;
- extraordinary maintenance is carried out on the machine, clamps, or decoders.

N.B.: ensure that the clamp is properly positioned against the mechanical stop and the clamp and its seat are both perfectly clean.

Every time the cutting tool is replaced the tool pre-setting operation is carried out automatically by the machine.

WARNING: the J1 (standard) clamp is used as a model for the description of clamp set-up operations. If using other clamps, enter the code for the clamp installed and use the same sequence.

OPERATIONS ON THE PC

- 1) Select the 'Clamp' item from the Accessories menu in the Silca Quattrocode Program software;
- 2) select the item "clamp set-up" and press <ENTER>;
- 3) enter the clamp code (J1) in the space indicated by the cursor:

<CLAMP NO.: J1>

- 4) press key F10

To transmit the set-up program to the cutting machine (make sure that the machine is switched on and connected to the PC).

OPERATIONS ON THE MACHINE

Press

<J1>

Press

<J1 - A
ST = 0>

Press 

<INSTALL DECODER U101>

Take the decoder from its housing (fig. 12, page 17).

If the decoder is taken from its housing and is not recognized by the machine when fitted into the spindle, the following message appears:

<DECODER MISSING>

The machine will go through the setting up operations only if there is a decoder in the spindle. Proceed as described in the chapter 'Replacing the cutting tool'.

Press 

The machine will set itself up. If the spindle is open and the decoder has not been fitted, the following message appears:

<DECODER MISSING>

If the spindle is locked without the cutting tool in it, the machine starts, only to stop when it reaches the safety measurement stops.

When set-up has been carried out the PC screen shows the OFFSET data (i.e. the variation from "theoretical zero", expressed in hundredths of millimetres) for the X, Y and Z axes.

5 DECODING KEYS

WARNING: *to install the key in the clamp, see Ch. 'Appendix 1 - Clamps'.*

5.1 Decoding

WARNING: *the J1 (standard) clamp is used as a model for the description of clamp decoding operations. If using other clamps, enter the code for the clamp installed and use the same sequence.*

To carry out decoding operations, work from the PC and then the machine, according to the following instructions.

OPERATIONS ON THE PC

- 1) Open the search menu.
- 2) Select the <SEARCH> function.
- 3) Enter the name of the system/lock.
- 4) Press <F10> to display further information on the system/lock selected.
- 5) Select the item 'Key decoding' from the main menu.

When ENTER is pressed the computer transfers the data to the key-cutting machine (make sure that the machine is on and connected to the PC).

OPERATIONS ON THE MACHINE

Press 

<DECODE...>

Press 

<J1 - A
ST = 0>

Raise the protective shield and place the key all the way into the clamp (fig. 19, page 21).

Press 

<INSTALL
DECOD U...>

Raise the protective shield and place the decoder in position (as per chap. 19, page 21). Lower the protective shield.

Press  and begin the decoding operation; the display will show:

<DECODE (...)>

The results of the decoding operations will appear on the PC video screen.

6 KEY CUTTING

6.1 Data storage in the machine memory

Quattrocode has a BACK-UP battery which makes it possible to memorize data transmitted by the PC, even after the machine is turned off.

N.B.: turning on the Quattrocode activates the cutting program last memorized before switching off the machine.

WARNING: *the J1 (standard) clamp is used as a model for the description of clamp set-up operations. If using other clamps, enter the code for the clamp installed and use the same sequence.*

6.2 Code selection

OPERATIONS ON THE PC

Enter the command

<QCODE> + ENTER

The general screen display appears.fig. 1.

Open the search menu.

Select the <SEARCH> function.

Enter the name of the system/lock.

Press <F10> to display further information on the system/lock selected.

Select the item 'Enter cutting data' from the menu.

Press <ENTER>

Enter the cutting data and press key <F10> to confirm transmission of the data to the key-cutting machine.

OPERATIONS ON THE MACHINE

When the QUATTROCODE is turned on (make sure it is connected to the PC) the machine display shows the words:

<QUATTROCODE
OK>

Press 

The display shows:

<ORIGINAL SYSTEM/LOCK>

Place the key into the clamp:

- 1) Raise the protective shield (D).
- 2) Place the key blank into the clamp (chap. 4.4, page 19).
- 3) Lower the protective shield.

Press  , the message will appear:

<INSTALL CUTTING TOOL>

Press 

When the cutting cycle is finished, follow the instructions shown on the display.

7 TEST FUNCTIONS

WARNING: *the test functions can be carried out only when the PC is connected to the QUATTROCODE.*

In the event of faults or malfunctioning a search can be made for the part involved by means of a series of TEST functions run by the PC.

The diagnoses shown here enable the Silca After-Sales Service to recommend remedial action. Should any faults occur which are not included in the tests, contact the Silca After-Sales Service.

The test function is called up by means of the  key

The key is active when the red led is illuminated and the display shows the message:

<TEST ???>

Select one of the functions run by the PC, illustrated in the SILCA QUATTROCODE PROGRAM, and transmit to the machine.

During the test the display shows the number of the test selected on the PC (except for "Test 401: Display", page 33). E.g.:

<TEST 101>

To leave the TEST mode, press the TEST key again.

The red led on the TEST key will go out and the display will be cleared of any messages.

7.1 Sensor test

The Quattrocode is provided with a number of proximity sensors for :

- X - Y - Z axes - A (spindle)
- clamp detection
- decoder pocket
- B axis (for future use)
- Z axis adjustment plate

Test 101: X axis sensor (lateral carriage)

- Moving the X axis carriage manually towards the right-hand end of run will activate the sensor and the display will show:

<TEST 101 OFF>

- Moving to the left the display will show:

<TEST 101 ON>

If no messages appear on the display contact Silca After-Sales Service.

Test 102: Y axis sensor (front carriage)

- When the Y axis carriage is moved by hand slowly towards the external end of run in the direction of the operator the display will show:

<TEST 102 ON>

- When the carriage is moved towards the machine the display will show:

<TEST 102 OFF>

If the transition from ON to OFF does not occur, contact Silca After-Sales Service.

Test 103: Z axis sensor (vertical carriage)

Remove the protective cover (L1) (fig. 25, page 36) to gain access to the vertical carriage.

- When the Z axis carriage is moved upwards the display will show:

<TEST 103 ON>

- When moved downwards the display will show:

<TEST 103 OFF>

If the transition from ON to OFF does not occur, contact Silca After-Sales Service.

Test 104: A axis sensor (spindle)

- When the coupling between the motor and spindle release screw is turned manually both clockwise and anticlockwise so as to cover and uncover the sensor the display will show the following messages:

<TEST 104 ON>

<TEST 104 OFF>

If the transition from ON to OFF does not occur, contact Silca After-Sales Service.

Test 105: clamp detection sensor

- The sensor is normally deactivated:

<TEST 105 OFF>

- When a metal object is placed under the sensor, at a distance of approx. 0.5 mm, the display will show:

<TEST 105 ON>

If the transition from ON to OFF does not occur, contact Silca After-Sales Service.

Test 106: Z axis gauging sensor (adjusting plate - H1)

- The sensor is normally deactivated:

<TEST 106 OFF>

With the jumper cable (see "Accessories provided", page 11) make electrical contact between the spindle chuck (C) and the adjusting plate (T) (fig. 23). The display will show:

<TEST 106 ON>

If the transition from ON to OFF does not occur, contact Silca After-Sales Service.

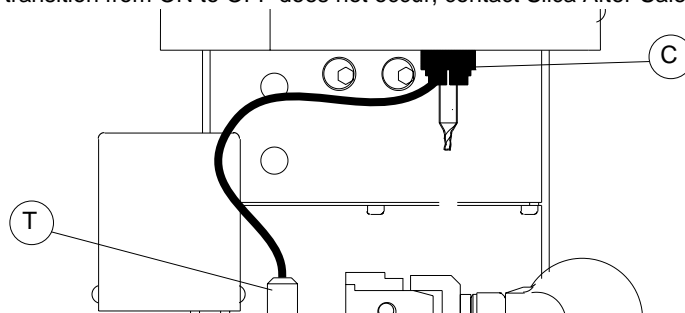

Fig. 23

Test 107: B axis sensor (supplementary - optional)

The B axis is provided for the future use of additional devices for the Quattrocode, such as special clamps which will be controlled through the B connection on the right-hand side of the machine (in the standard version of the Quattrocode this function is not activated).

Test 108: decoder sensor (decoder pocket - E)

If all the decoders are housed in the special pocket a contact closes and the display shows:

<TEST 108 ON>

- When the two decoders are removed alternately, the display will show:

<TEST 108 OFF>

If the transition from ON to OFF does not occur, contact Silca After-Sales Service.

7.2 Photocell test

In addition to the sensors already described there are two photocells for micrometric detection of the X and Y carriage end of runs.

Test 201: X axis photocell (lateral carriage)

- When the carriage is moved very slowly by hand to the right then to the left, the display will show:

<TEST 201 ON>

<TEST 201 OFF>

If the transition from ON to OFF does not occur, contact Silca After-Sales Service.

Test 202: Y axis photocell (front carriage)

- When the carriage is moved very slowly by hand towards the machine then back towards the operator, the display will show:

<TEST 202 ON>

<TEST 202 OFF>

If the transition from ON to OFF does not occur, contact Silca After-Sales Service.

Test 203: B axis photocell (supplementary - optional)

The B axis is provided for the future use of additional devices for the Quattrocode, such as special clamps which will be controlled through the B connection on the right-hand side of the machine (in the standard version of the Quattrocode this function is not activated).

7.3 Motor tests



WARNING: *tests for the step motors (X - Y- Z- A ...) consist of checking their electrical operation. The tests do not check the end of runs (sensors and photocells), so that the motors can run up to the mechanical stops.*

The motors should therefore be tested in both directions without reaching the mechanical stops, as this would risk straining the machine.

Test 301: X axis motor (lateral carriage)

- With the motor off the display will show:

<TEST 301>

Hold down the  key (right-hand arrow) or  (left-hand arrow) to move the motor in the two directions.



When the key is released the motor stops immediately
If the motor will not start, contact Silca After-Sales Service.

WARNING: *if the motor reaches end of run, stop it immediately to avoid unnecessary strain on the structure.*

Test 302: Y axis motor (front carriage)

- With the motor off the display will show:

<TEST 302>

Hold down the  key (right-hand arrow - towards the operator) or  (left-hand arrow - towards the machine) to move the motor in the two directions.



When the key is released the motor stops immediately
If the motor will not start, contact Silca After-Sales Service.

WARNING: *if the motor reaches end of run, stop it immediately to avoid unnecessary strain on the structure.*

Test 303: Z axis motor (vertical carriage)

- With the motor off the display will show:

<TEST 303>

Hold down the  key (right-hand arrow - upwards) or  (left-hand arrow - downwards) to move the motor in the two directions.

When the key is released the motor stops immediately
If the motor will not start, contact Silca After-Sales Service.

WARNING: *if the motor reaches end of run, stop it immediately to avoid unnecessary strain on the structure.*



WARNING: *if one of the cutting tools is fitted into the spindle, moving the carriage down may cause the tool to bump into the clamp!*

Test 304: A axis motor (spindle)

(make sure that a cutting tool is installed).

- With the motor off the display will show:

<TEST 304>

Hold down the  key (right-hand arrow) or  (left-hand arrow) to start the motor turning clockwise or anticlockwise.

When the key is released the motor stops immediately
If the motor will not start, contact Silca After-Sales Service.

WARNING: *if the motor reaches end of run, stop it immediately to avoid unnecessary strain on the structure.*

Test 305: B axis photocell (supplementary - optional)

The B axis is provided for the future use of additional devices for the Quattrocode, such as special clamps which will be controlled through the B connection on the right-hand side of the machine (in the standard version of the Quattrocode this function is not activated).

Test 306: cutting tool motor (slow speed)

(make sure there is a cutting tool in the spindle so that the chuck is locked).

- With the motor off the display will show:

<TEST 306>

Hold down the  key to start the motor.

When the key is released the motor stops immediately.
If the motor will not start, contact Silca After-Sales Service.

Test 307: cutting tool motor (high speed)

(make sure there is a cutting tool in the spindle so that the chuck is locked).

WARNING: *for this TEST the protective shield must be lowered.*

- With the motor off the display will show:

<TEST 307>

Hold down the  key to start the motor.

When the key is released the motor stops immediately.
If the motor will not start, contact Silca After-Sales Service.

7.4 Display and keypad test

Test 401: Display

On receiving instructions from the PC all the illuminated segments will light up in turn (fig. 24). The test ends when all segments are illuminated and is then automatically repeated.

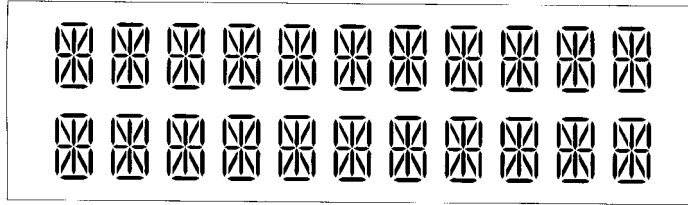

Fig. 24

If any of the segments fail to light up, contact Silca After-Sales Service.

The display test can be interrupted by running another test from the PC or by pressing the TEST key on the keypad.

Test 402: Keypad

- Number of test on the display:

<TEST 402>

Pressing any key (except the TEST key which disactivates the test function) should cause the symbol on the key to appear on the display.

EXAMPLE:

When the  key is pressed the display will show:

<START>

If any of the keys fail to respond or if the symbol displayed does not correspond to that on the key, contact Silca After-Sales Service.

8 CLEANING

- Under no circumstances must compressed air be used to clear the work area of chippings, as these may find their way into the working parts of the machine.
- Use a brush to periodically clean the chippings from the protective bellows on the carriage guides.
- Do not use oily substances or solvents to clean the painted surfaces, clamps, electrical or electronic connectors.

9 MAINTENANCE

WARNING: *for repairs or replacement of parts for maintenance, the 'CE' mark is guaranteed only if original spare parts provided by the manufacturer are used.*

Although the QUATTROCODE key-cutting machine does not require special maintenance, it is advisable to check and, if necessary, replace the parts subject to wear and replace electrical/electronic parts when faulty (fuses, circuit boards, etc.). Replacement is simple and can be carried out by the operator, following the instructions given.

Before starting any type of maintenance (checks or replacements), read the instructions below:

- never carry out maintenance operations when the machine is operating
- always disconnect the mains power supply
- follow the instructions in the manual to the letter
- use only original spare parts.

9.1 Trouble shooting

FAULTS	CHECKS AND REPLACEMENT
Although the machine is on the display remains black with no messages	<p>The fan on the back of the machine is not working:</p> <ul style="list-style-type: none"> - check that the emergency button is released - check fuse A on the supply socket (chap. 9.4, page 37) - check that the switch on the electronic rack supply module is in the ON position (chap. 9.5, page 40) <p>The fan on the back of the machine is working</p> <ul style="list-style-type: none"> - check the connection between the display and keypad (chap. 9.11, page 46). - check that the +5V green led on the electronic rack supply module is on. If it is off, replace the module (chap. 9.5, page 40). - re-transmit the machine program from the PC to the Quattrocode (chap. 3.4, page 15).
The cutting tool motor will not start	<ul style="list-style-type: none"> - check fuse G (chap. 9.4, page 37). - with the machine off, check that the cutting tool shaft turns freely when rotated by hand. - replace the cutting tool motor control board (chap. 9.7, page 42). - replace the I/O board (chap. 9.10, page 45). - replace the cutting tool motor (chap. 9.13, page 49).
The cutting tool motor runs only on 1st or 2nd speed	<ul style="list-style-type: none"> - replace the 1st and 2nd speed control board - replace the I/O board (chap. 9.10, page 45).
One of the axes is not moving	<ul style="list-style-type: none"> - with the machine off, check that there is no mechanical impediment to the axis when moved manually - check(chap. 9.4, page 37): <ul style="list-style-type: none"> a) fuse C for axes X and Y b) fuse D for axes Z and A (spindle release/lock) c) fuse E for axis B (rotating clamp) - replace the 1st ST2DRV module for the X and Y axes (chap. 9.6, page 41) - replace the 2nd ST2DRV module for the Z and A axes (chap. 9.7, page 42). - replace the 3rd ST2DRV module for the B axis motors (chap. 9.8, page 43).
The keypad is not working	<ul style="list-style-type: none"> - check the connection between the display and the keypad (chap. 9.11, page 46). - replace the keypad (chap. 9.11, page 46).
The X, Y or Z axes will not zero	<ul style="list-style-type: none"> - check fuse F (chap. 9.4, page 37). - check whether the sensors and photocells for the relevant axes are working properly; if not, replace them
The machine loses the operating program continually (when switched on, the display remains black and the program needs to be re-transmitted from the PC)	<ul style="list-style-type: none"> - replace the supply board (chap. 9.5, page 40). - replace the CPU board (chap. 9.9, page 44).
Communication between the machine and PC fails	<ul style="list-style-type: none"> - check the computer set-up (serial port, communication speed, etc.) - replace the CPU board (chap. 9.9, page 44).

9.2 Maintenance operations

- Spindle belt replacement
- Belt tension
- Checking and replacing the fuses
- Replacing the circuit boards in the electronic rack
- Replacing the keypad/display
- Replacing the electronic rack
- Access to the motor compartment

9.3 Belt replacement and tension

- 1) loosen the 2 side screws (L2) and remove the belt cover (L1) by pushing upwards (fig. 25);
- 2) loosen the seven fixing screws (Z1), remove the top cover (Z) and push upwards, making sure the keypad wiring (Z2) is detached (fig. 25);
- 3) partly loosen the two nuts (Y) securing the motor, using the special elbow wrench (Y4) and rod (Y3) (both provided), as shown in fig. 26;
- 4) use the special rod provided (Y3) to move the tension eccentric (Y1) and loosen the belt;
- 5) take the belt off the pulleys;
- 6) detach the spindle release motor connector (Y2) (fig. 26);
- 7) remove the worn belt;
- 8) fit the new belt and re-connect the spindle motor connector (Y2), taking care that the motor wiring does not come into contact with the belt;
- 9) place the belt onto the pulleys.

WARNING: when the belt has been replaced, check the direction of rotation.

- 10) adjust tension with the tension eccentric cam (Y1) then secure the cutting tool motor by tightening the two nuts (Y) (fig. 26).

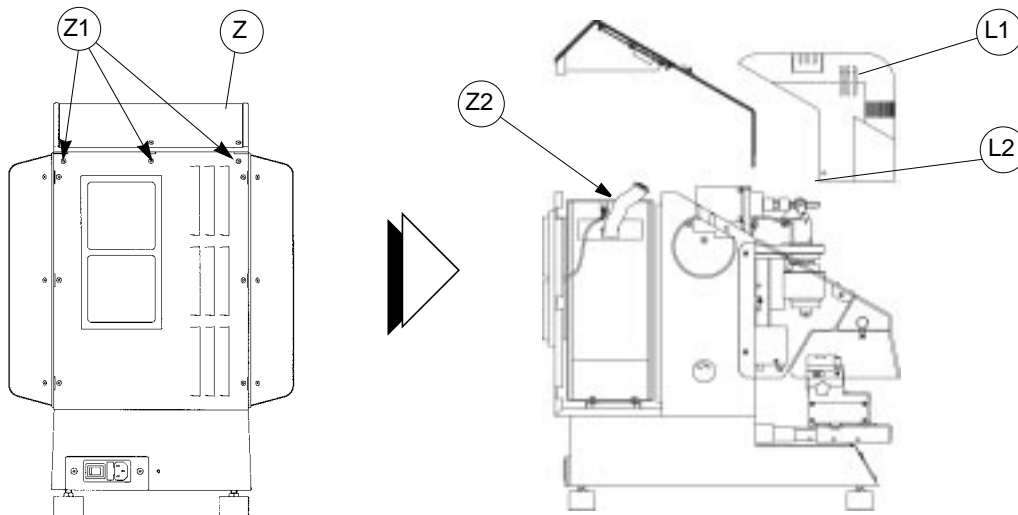

Fig. 25

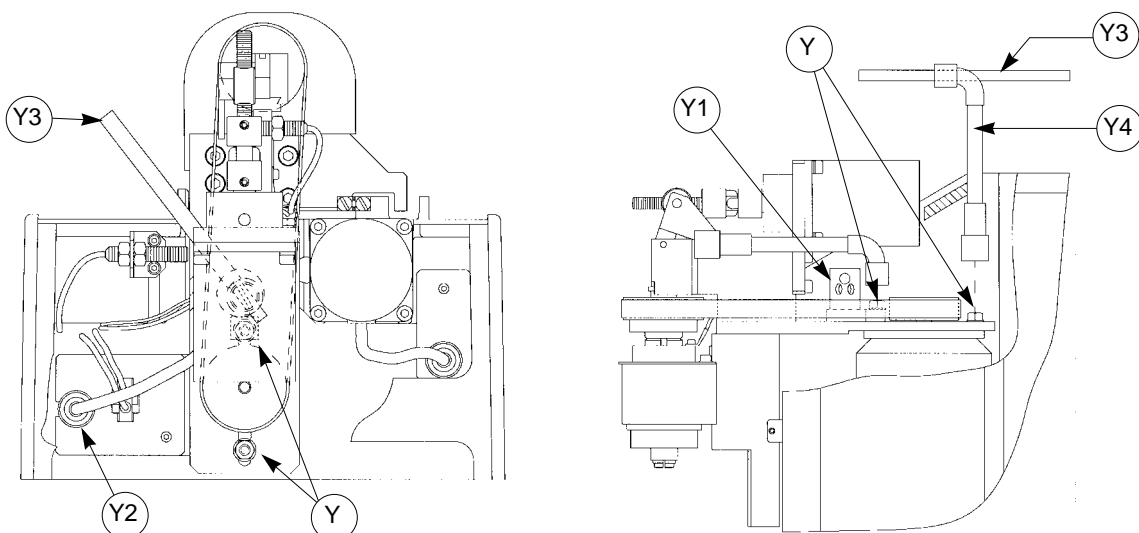

Fig. 26

9.4 Checking and replacing the fuses

There are seven fuses in the machine A-B-C-D-E-F (fig. 29, page 38), placed in different positions so as to guarantee protection for the electronic parts in the event of the mains supply voltage fluctuating and to avoid any faults in the circuit boards spreading and damaging other parts of the electric or electronic circuits.

N.B.: fuses must always be checked with an instrument for measuring continuity (tester, ohmmeter, multimeter, etc.) as they may appear visibly intact even when they have cut out.

Each must be replaced by one with exactly the same number of Amps and of the same type (rapid or delayed), as shown in the manual.

A - Master fuse

4 Amp. - rapid (110V: 8 Amp. - rapid)

This is fitted to the machine supply plug (fig. 27) (which also contains a spare fuse). When this fuse cuts out, Quattrocode is completely cut off, the display shows nothing, there is no response to any of the control keys and there is no communication with the PC.

To replace fuses B-C-D-E-F in the electronic rack, remove the cover (O) as follows:

- 1) disconnect the supply wiring
- 2) remove the three screws (O1) (fig. 27 - rear view)
- 3) remove the cover (O) by pushing in the direction of the arrows (fig. 28).

WARNING: do not bend the cover during this operation as the attachment hooks could easily be broken.

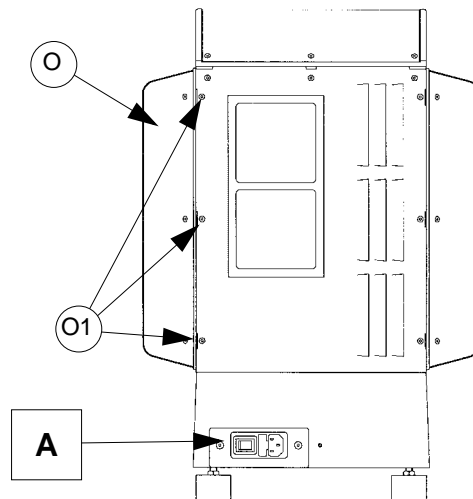

Fig. 27

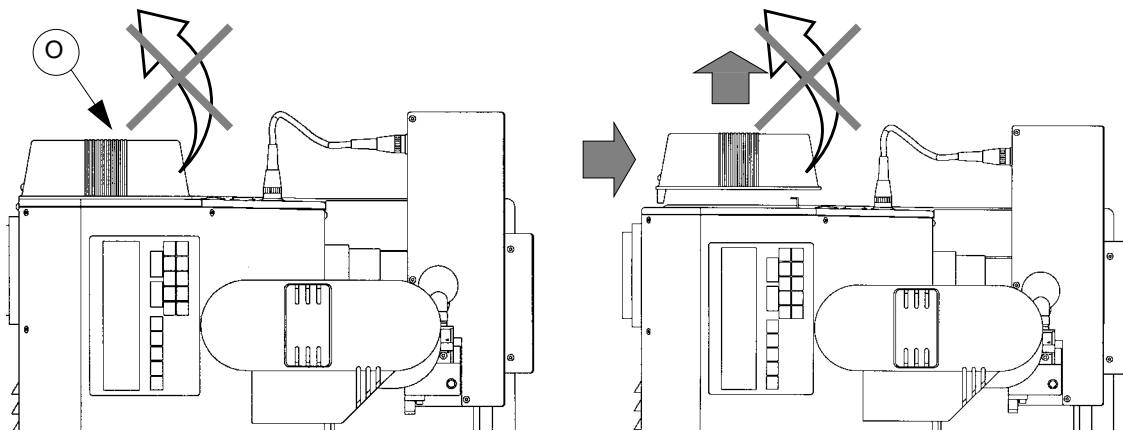

Fig. 28

B - Inlet fuse for electronic rack

"1 amp - delayed"

When this fuse cuts out the two green leds (+5 Volt dc and + 12 Volt dc) on the UNIPOW 50 supply module on the electronic rack go off, the display shows nothing, there is no response to any control key and there is no communication with the computer.

C - X and Y axes step motor protection fuse

"4 amp - delayed"

When this fuse cuts out the relevant green led for the ST2DRV_electronic module goes off and the X and Y axes carriages will not move.

To replace this fuse, remove the 1st ST2DRV module from the rack (chap. 9.6, page 41). Remove the four screws (V1) in order to separate the top part (V) of the dissipator and gain access to fuse C on the circuit board (fig. 30).

N.B.: after replacing the fuse, fit the dissipator (V) securing the locking screws (V1) tightly to ensure good heat conductivity between the parts in contact (fig. 30).

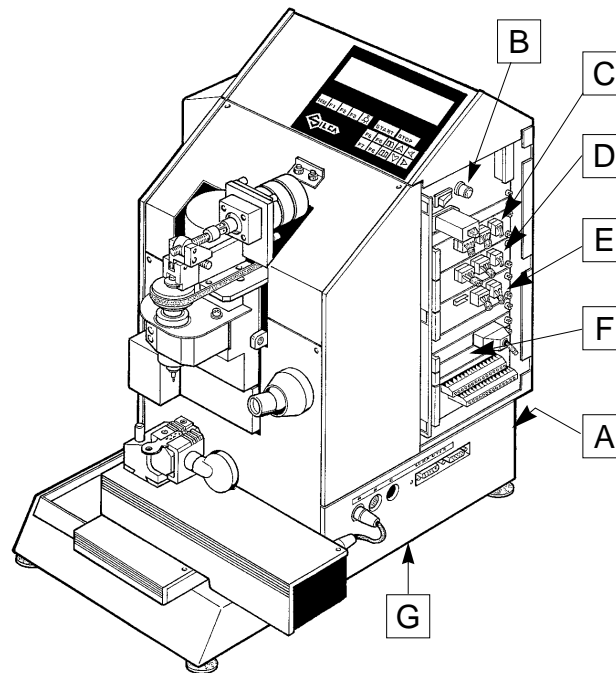

Fig. 29

D - Z and A axes step motor protection fuse

"4 amp - delayed"

When this fuse cuts out the relevant green led for the ST2DRV electronic module goes off, the Z axis carriage will not move and the cutting tool spindle will neither open nor close.

To replace this fuse, remove the 2nd ST2DRV module from the rack (chap. 9.7, page 42). Remove the four screws (V1) in order to separate the top part of the dissipator and gain access to the fuse on the circuit board (fig. 30).

N.B.: after replacing the fuse, fit the dissipator (V), securing the locking screws (V1) tightly to ensure good heat conductivity between the parts in contact (fig. 30).

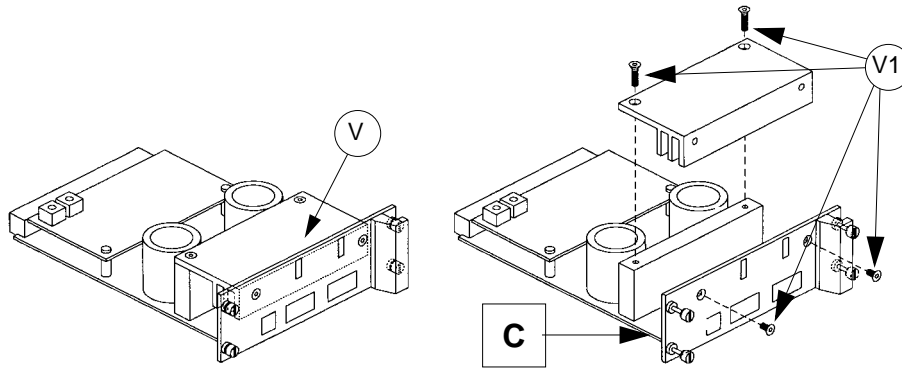

Fig. 30

E - Step motor protection fuse for supplementary motorized clamp (optional).

"4 amp - delayed"

When this fuse cuts out the green led for the ST2DRV electronic module goes off and the clamp will not activate.

To replace this fuse, remove the 3rd ST2DRV module from the rack (chap. 9.8, page 43). Remove the four screws (V1) in order to separate the top part (V) of the dissipator and gain access to the fuse on the circuit board (fig. 30).

N.B.: after replacing the fuse, fit the dissipator (V), securing the locking screws (V1) tightly to ensure good heat conductivity between the parts in contact (fig. 30).

F - Protection fuse for sensors/outlets

"1.6 amp - delayed"

When this fuse cuts out the green led for the inlet/outlet module goes off and despite the display being on and the keyboard activated, none of the sensors are read (the axes cannot find the zero position) and none of the actuators receive power (the cutting tool motor will not work, etc.).

To replace this fuse remove the inlet/outlet module from the rack (chap. 9.10, page 45).

G - Cutting tool motor protection fuse

"3.15 amp - rapid" (110V: '3.15 amp - rapid')

When this fuse cuts out the cutting tool motor will not work.

The fuse is to be found on the circuit board which regulates the motor speed, positioned in the base of the machine (chap. 9.14, page 50).

9.5 Replacing the UNIPOW 50 Supply circuit board

When the UNIPOW 50 supply board is working properly the two 5V dc and 12V dc green leds are illuminated and the leds on the display rotate; the P.F. red led must be off (fig. 31). Any other signals indicate a fault; in such cases contact the Silca After-Sales Service. If it is necessary to replace the board, proceed as follows:

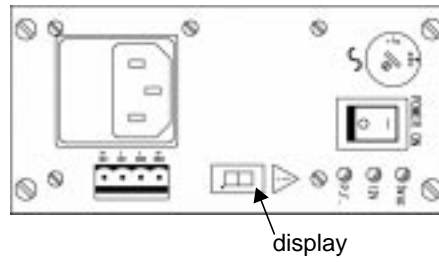

Fig. 31

- 1) switch off the machine and disconnect the supply wire.
- 2) remove the three screws (O1) (fig. 32 - rear view)
- 3) detach the cover (O), pushing in the direction of the arrows (fig. 33)

WARNING: *do not bend the cover during this operation as the attachment hooks could easily be broken.*

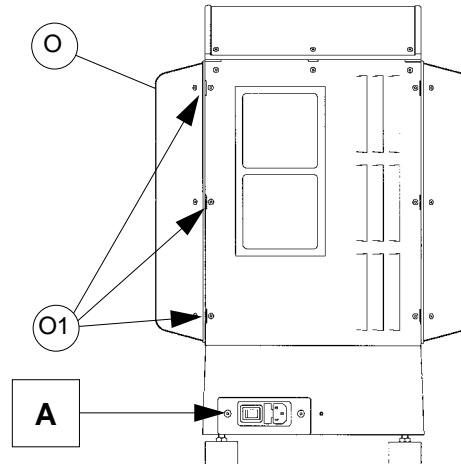

Fig. 32

- 4) disconnect the plug 1 (fig. 34) and loosen the four screws (W) securing the module (it is not necessary to remove them).
- 5) slide the module from the rack and replace with a new one.
- 6) secure with the four screws (W) and replace the plug 1.

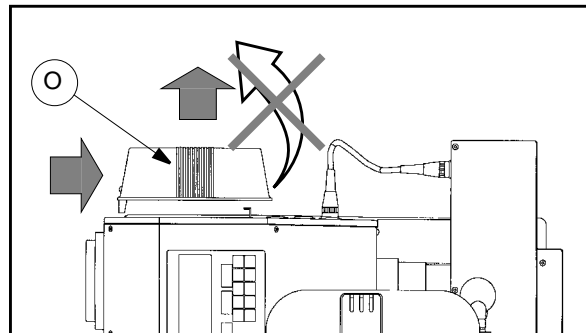

Fig. 33

WARNING: *replacing this module, which contains the buffer battery for data in the RAM memory, causes loss of the operating program.*

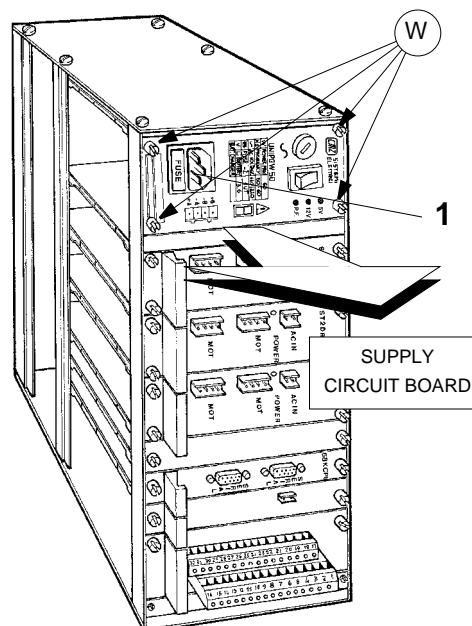

Fig. 34

9.6 Replacing the 1st ST2DRV module - X and Y axes step motors

- 1) switch off the machine and disconnect the supply wire.
- 2) remove the cover (O) (chap. 9.5, page 40).

WARNING: *do not bend the cover during this operation as the attachment hooks could easily be broken.*

- 3) disconnect the plug 1 from the supply module.
- 4) disconnect the wires:
 - 2 (Y axis motor)
 - 3 (X axis motor)
 - 4 (module supply board)
- 5) loosen the four screws (W) securing the module (it is not necessary to remove them) (fig. 36).
- 6) slide the module from the rack and replace with a new one after positioning the commutators (W1) and (W2) (fig. 36).

COMMUTATOR W1 = 0 X axis motor selection

COMMUTATOR W2 = 1 Y axis motor selection

N.B.: use a suitable screwdriver to turn the commutators; if they are damaged the whole module will be affected.

- 7) secure the new module with the four screws (W) and re-connect wires 2/3/4 and plug 1.

N.B.: the 1st ST2DRV module (X and Y axes motors) and the 2nd ST2DRV module (Z and A axes motors - spindle) are interchangeable. Remember to position the selection commutators (W1) and (W2) (fig. 36) according to the motors connected to the module.

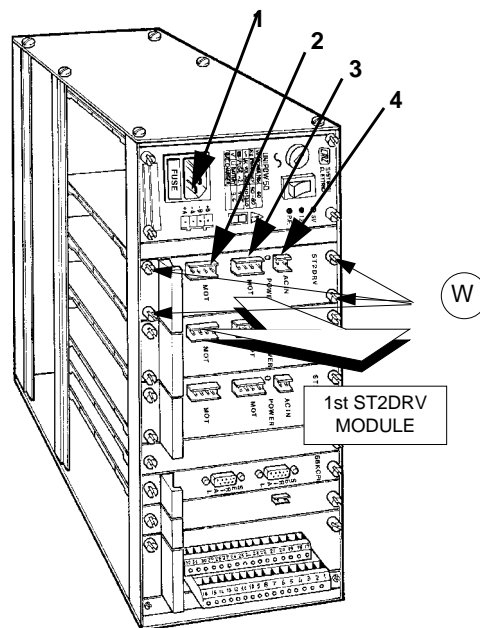

Fig. 35

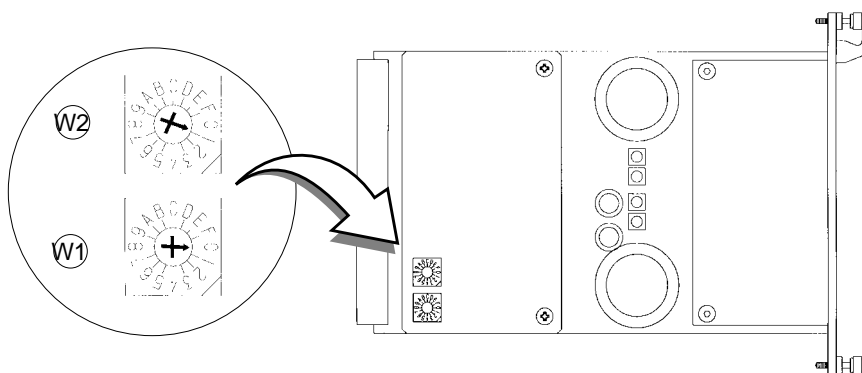

Fig. 36

9.7 Replacing the 2nd ST2DRV module - Z and A axes step motors

- 1) switch off the machine and disconnect the supply wire.
- 2) detach the cover (O) (chap. 9.5, page 40).

WARNING: *do not bend the cover during this operation as the attachment hooks could easily be broken.*

- 3) disconnect the plug 1 from the supply module.
- 4) disconnect the wires:
 - 2 (Y axis motor)
 - 3 (X axis motor)
 - 4 (module supply board)
 - 5 (A axis motor)
 - 6 (Z axis motor)
 - 7 (module supply board)
- 5) loosen the four screws (W) securing the module (it is not necessary to remove them) (fig. 37).
- 6) slide the module from the rack and replace with a new one after positioning the commutators (W1) and (W2) (fig. 37).

COMMUTATOR W1 = 2 Z axis motor selection

COMMUTATOR W2 = 3 A axis motor selection

N.B.: use a suitable screwdriver to turn the commutators; if they are damaged the whole module will be affected.

- 7) secure the new module with the four screws (W) and re-connect wires 2/3/4/5/6/7 and plug 1.

N.B.: the 1st ST2DRV module (X and Y axes motors) and the 2nd ST2DRV module (Z and A axes motors - spindle) are interchangeable. Remember to position the selection commutators according to the motors connected to the module.

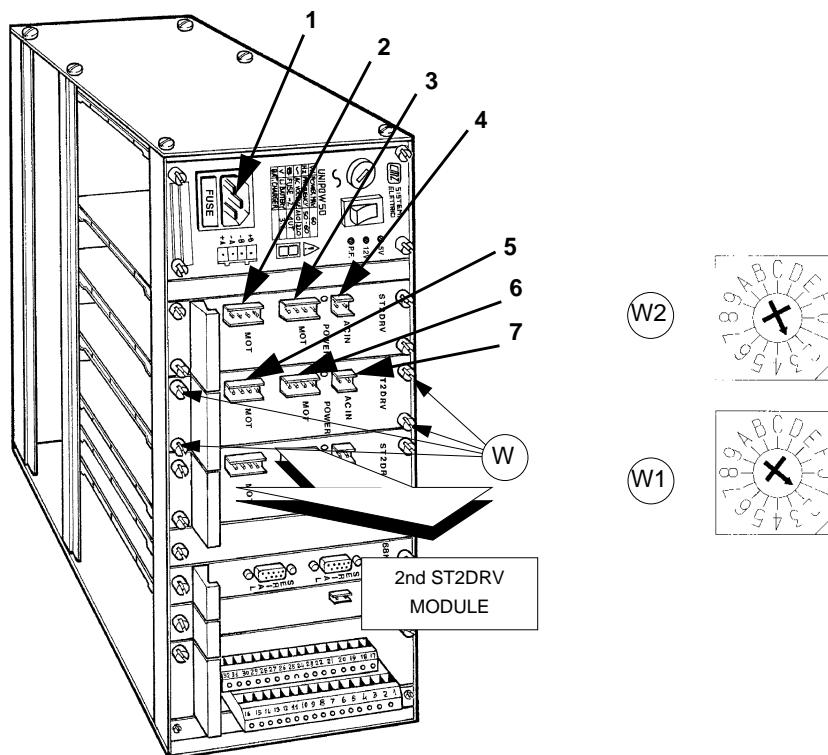

Fig. 37

9.8 Replacing the 3rd ST2DRV module - B axis step motor

- 1) switch off the machine and disconnect the supply wire.
- 2) detach the cover (O) (chap. 9.5, page 40).

WARNING: *do not bend the cover during this operation as the attachment hooks could easily be broken.*

- 3) disconnect the plug 1 from the supply module.
- 4) disconnect the wires:
 - 2 (Y axis motor)
 - 3 (X axis motor)
 - 4 (module supply board)
 - 5 (A axis motor)
 - 6 (Z axis motor)
 - 7 (module supply board)
 - 8 (B axis motor)
 - 9 (module supply board)
- 5) loosen the four screws (W) securing the module (it is not necessary to remove them) (fig. 38).
- 6) slide the module from the rack and replace with a new one after positioning the commutator (W3) (fig. 38).

COMMUTATOR W1 = 4 (not in use)
 COMMUTATOR W2 = 5 B axis motor selection

N.B.: use a suitable screwdriver to turn the commutator (W1); if it is damaged the whole module will be affected.

- 7) secure the new module with the four screws (W) and re-connect wires 2/3/4/5/6/7/8/9 and plug 1.

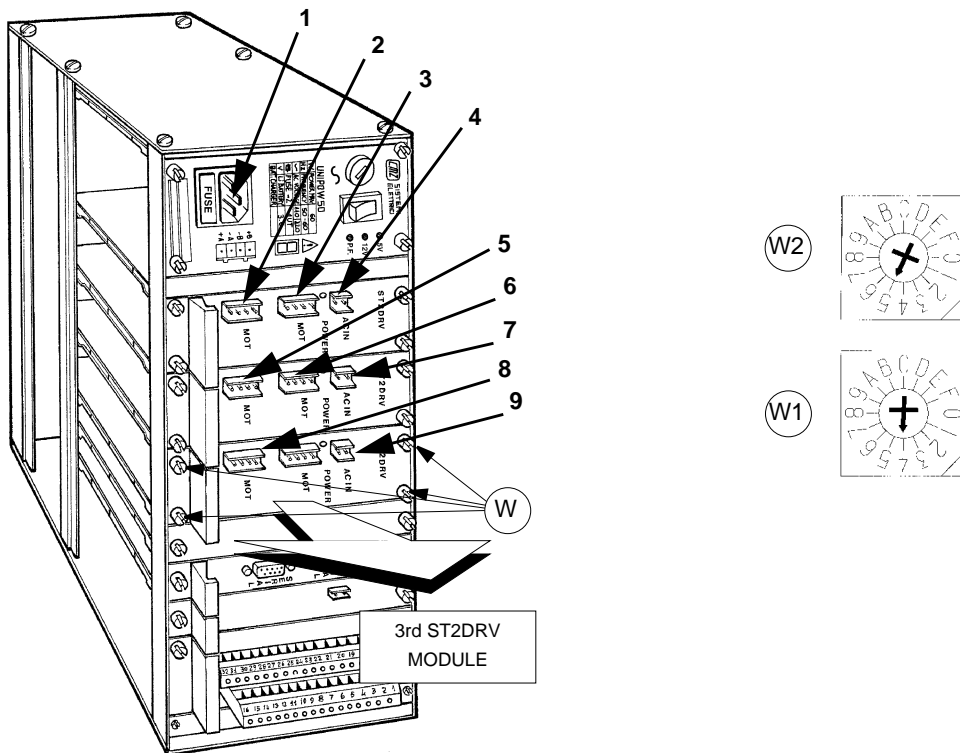

Fig. 38

9.9 Replacing the CPU module

- 1) switch off the machine and disconnect the supply wire.
- 2) detach the cover (O) (chap. 9.5, page 40).

WARNING: *do not bend the cover during this operation as the attachment hooks could easily be broken.*

- 3) disconnect the plug **1** from the supply module.
- 4) disconnect the wires:
 - **2** (Y axis motor)
 - **3** (X axis motor)
 - **4** (module supply board)
 - **5** (A axis motor)
 - **6** (Z axis motor)
 - **7** (module supply board)
 - **8** (B axis motor)
 - **9** (module supply board)
 - **10** (serial A)
 - **11** (serial B)
- 5) loosen the two screws (**W**) securing the module (it is not necessary to remove them) (fig. 39).
- 6) slide the module from the rack and replace with a new one.
- 7) secure the new module with the two screws (**W**) and re-connect wires **2/3/4/5/6/7/8/9/10/11** and plug **1**.

WARNING: *replacing this module, which contains the RAM memory, causes loss of the operating program.*

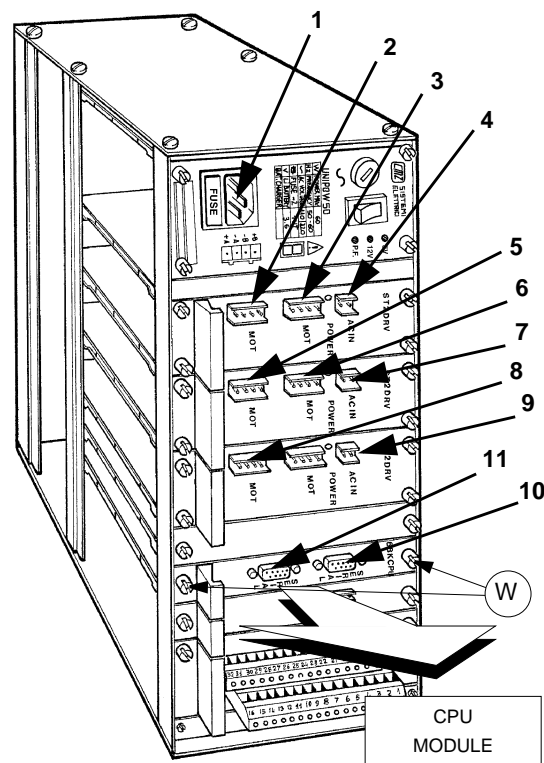

Fig. 39

9.10 Replacing the inlet/outlet modules and terminal panel

- 1) switch off the machine and disconnect the supply wire.
- 2) detach the cover (O) (chap. 9.5, page 40).

WARNING: *do not bend the cover during this operation as the attachment hooks could easily be broken.*

- 3) disconnect the plug 1 from the supply module.
- 4) disconnect the wires:
 - 2 (Y axis motor)
 - 3 (X axis motor)
 - 4 (module supply board)
 - 5 (A axis motor)
 - 6 (Z axis motor)
 - 7 (module supply board)
 - 8 (B axis motor)
 - 9 (module supply board)
 - 10 (serial A)
 - 11 (serial B)
 - 12 (inlet/outlet module supply board)

- 5) loosen the four screws (W) securing the module (it is not necessary to remove them) (fig. 40).
- 6) slide the module partially from the rack and separate the terminal panel from the inlet/outlet board (X) (fig. 41).
- 7) remove the inlet/outlet board completely, replace with the new one and insert partially into the rack.
- 8) attach the terminal panel to the board and insert the complete module in the rack.

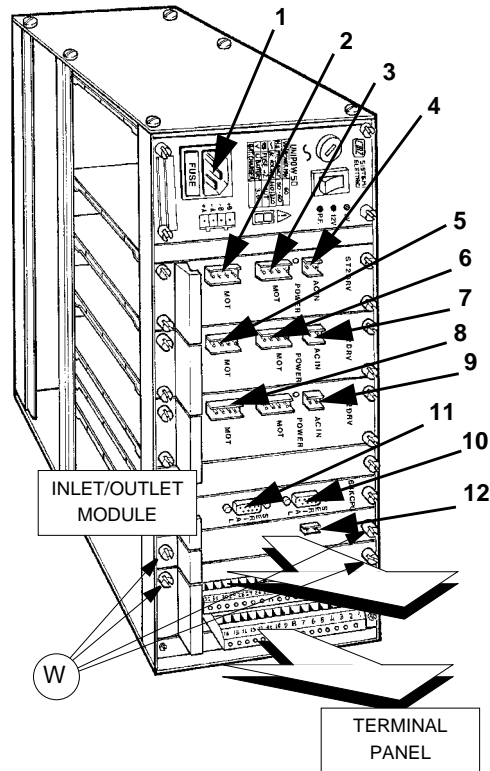

Fig. 40

N.B.: with this procedure it is not necessary to disconnect all the sensors and actuators on the terminal panel every time the inlet/outlet board must be removed. Take care that the board and the terminal panel are properly connected before replacing the module in the rack.

- 9) secure the new module with the four screws (W) (fig. 40) and re-connect wires 2/3/4/5/6/7/8/9/10/11/12 and plug 1.

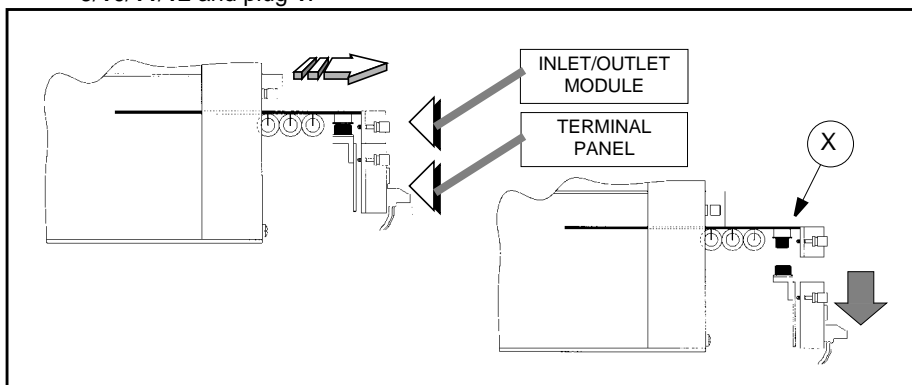

Fig. 41

9.11 Replacing the keypad/display

- 1) Switch off the machine and disconnect the supply wire.
- 2) Remove the belt cover (L1) by unscrewing the two side screws (L2) and raising it (fig. 42).
- 3) Remove the seven screws (Z1) and detach the upper panel (Z), complete with the keypad.
- 4) Disconnect the connector (Z2).
- 5) Remove the four nuts (Q1) and detach the keypad/display unit (fig. 43).
- 6) After replacing the unit re-assemble the elements repeating the above operations in reverse order.

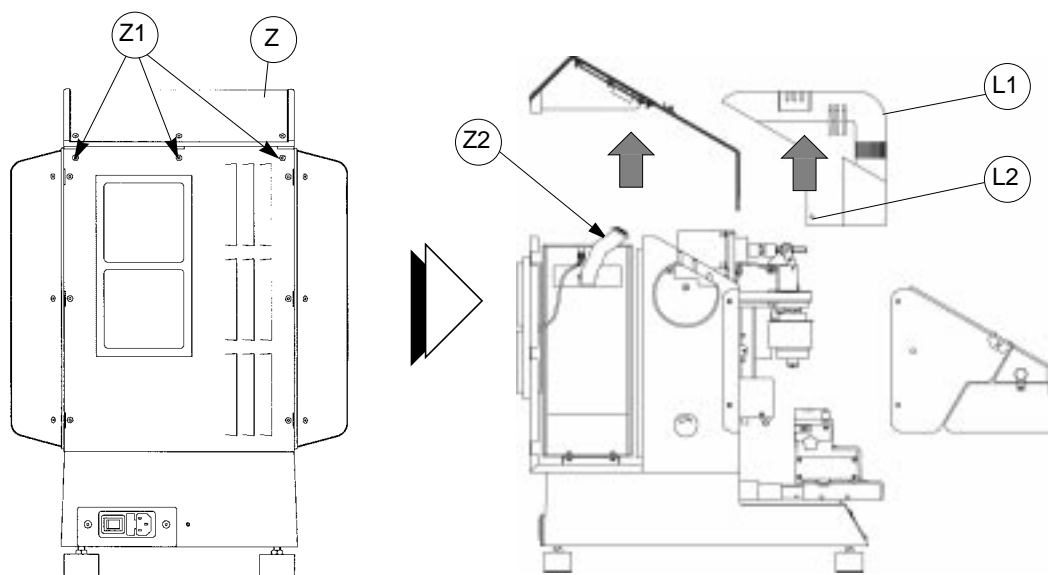

Fig. 42

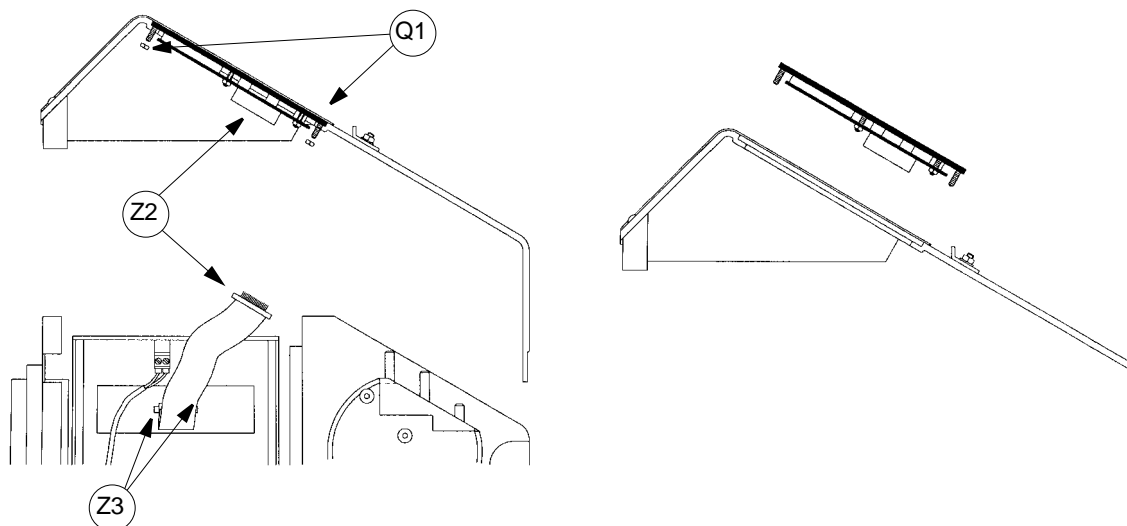

Fig. 43

9.12 Replacing the electronic rack

- 1) switch off the machine and disconnect the supply wire.
- 2) detach the cover (O) (chap. 9.5, page 40).

WARNING: *do not bend the cover during this operation as the attachment hooks could easily be broken.*

- 3) disconnect the plug 1 from the supply module.
- 4) disconnect the wires:
 - 2 (Y axis motor)
 - 3 (X axis motor)
 - 4 (module supply board)
 - 5 (A axis motor)
 - 6 (Z axis motor)
 - 7 (module supply board)
 - 8 (B axis motor)
 - 9 (module supply board)
 - 10 (serial A)
 - 11 (serial B)
 - 12 (inlet/outlet module supply board)

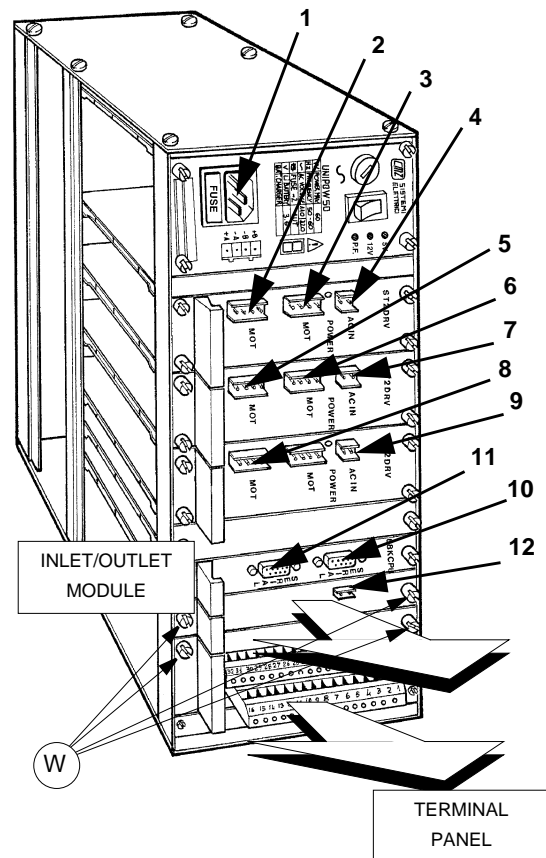

Fig. 44

- 5) loosen the four screws (W) securing the module (it is not necessary to remove them) (fig. 44).
- 6) slide the module partially from the rack and separate the terminal panel from the inlet/outlet board (X) (fig. 45).
- 7) remove the inlet/outlet board (X)
- 8) detach the small protective panel by removing the two screws (W) (fig. 45).
- 9) remove the two screws (L2) and detach the protective cover (L1) (fig. 46), raising it in the direction of the arrow.
- 10) release the flat cable (Z2) by pushing the two tabs (Z3) outwards (fig. 46).
- 11) remove the seven screws (Z1) and detach the upper panel (Z), complete with the keypad (fig. 42, page 46).
- 12) disconnect the two fan feed wires from the terminal panel (Z4) (fig. 46).
- 13) remove the four screws (K2) which secure the rack (K) to the machine and pull upwards (fig. 46, page 48).
- 14) to fit the new rack follow the instructions given in reverse order, taking care to connect the fan feed wires (Z4) correctly (the red wire to the terminal marked '+' and the black wire to the terminal marked '-') (fig. 46).

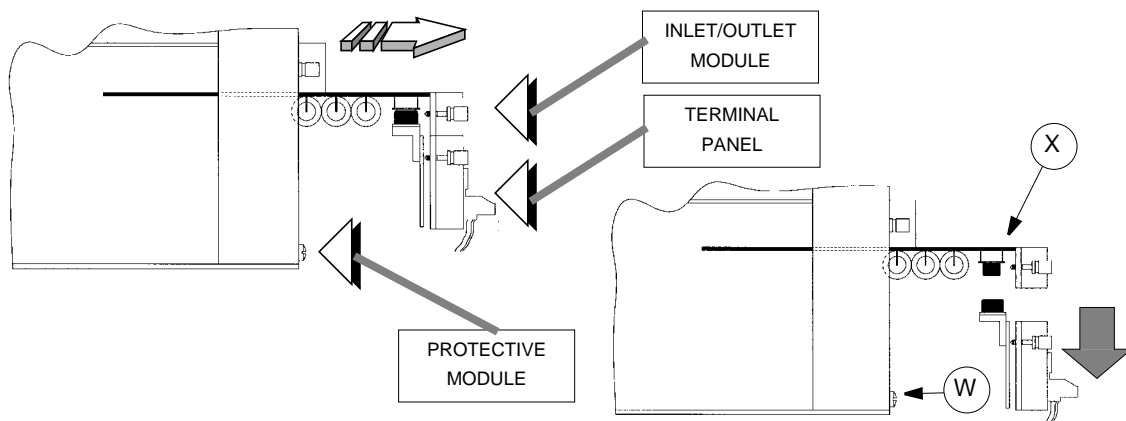

Fig. 45

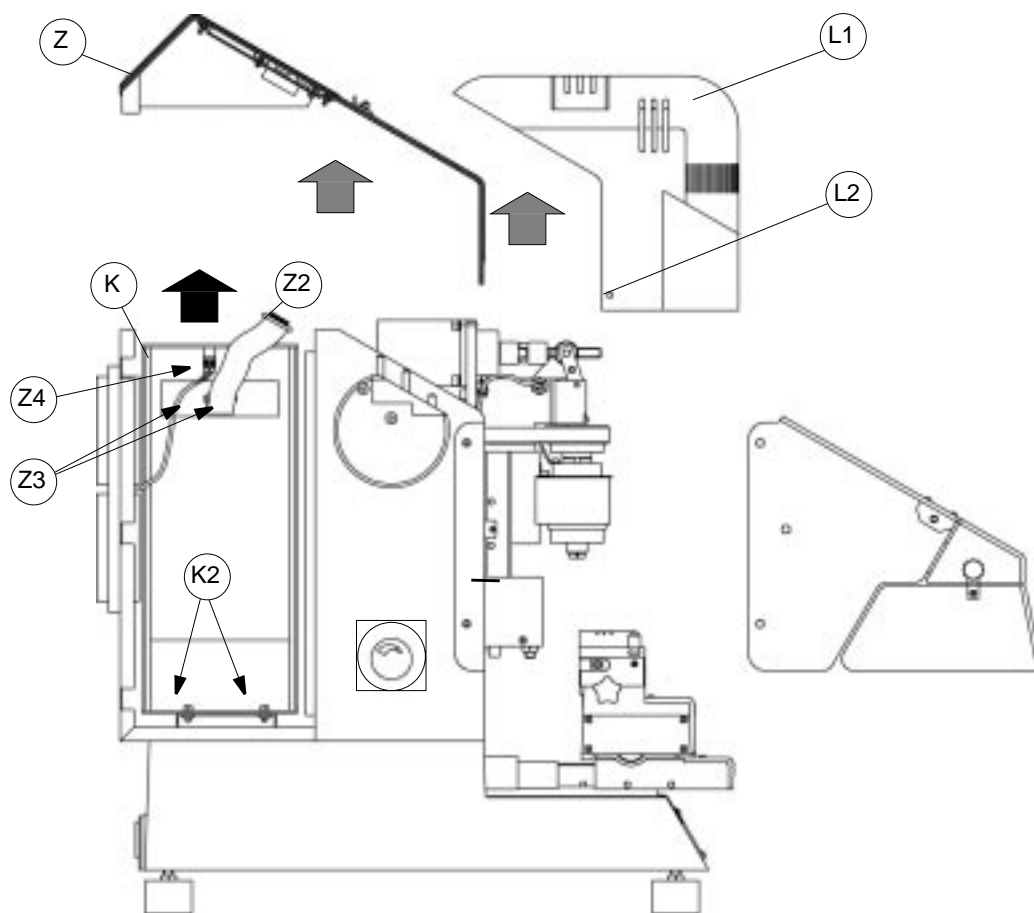

Fig. 46

9.13 Access to the motor compartment

It will be necessary to gain access to this compartment when you need to:

- replace the Z axis photocell wiring.
- replace the Z axis zero sensor.
- replace the spindle release/lock sensor.
- replace the electric contact wire for the Z axis.
- replace the internal connecting wires for the cutting tool motor and the microswitches for detecting the decoders.
- replace the wiring for the Z axis step motor.
- replace the wiring for the spindle step motor.
- check the internal parts of the Z axis movement.

WARNING: *it is very important that before the compartment is closed after replacing or checking parts the mobile wiring (M1) is properly secured and that it moves freely. Check by moving the Z axis carriage manually along its vertical run (the wiring should move along without catching on any of the internal parts).*

To gain access to the compartment:

- 1) Remove the electronic rack (see chapter 9.12 "Replacing the electronic rack", page 47).
- 2) Remove the five screws (X1) and remove the protective cover (X2) (fig. 47).
- 3) Remove the six screws (T1) and remove the plate (T2).
- 4) If necessary, remove the two screws (X3) and remove the rear part (X4) (this procedure gives full access to the motor compartment) (fig. 47).

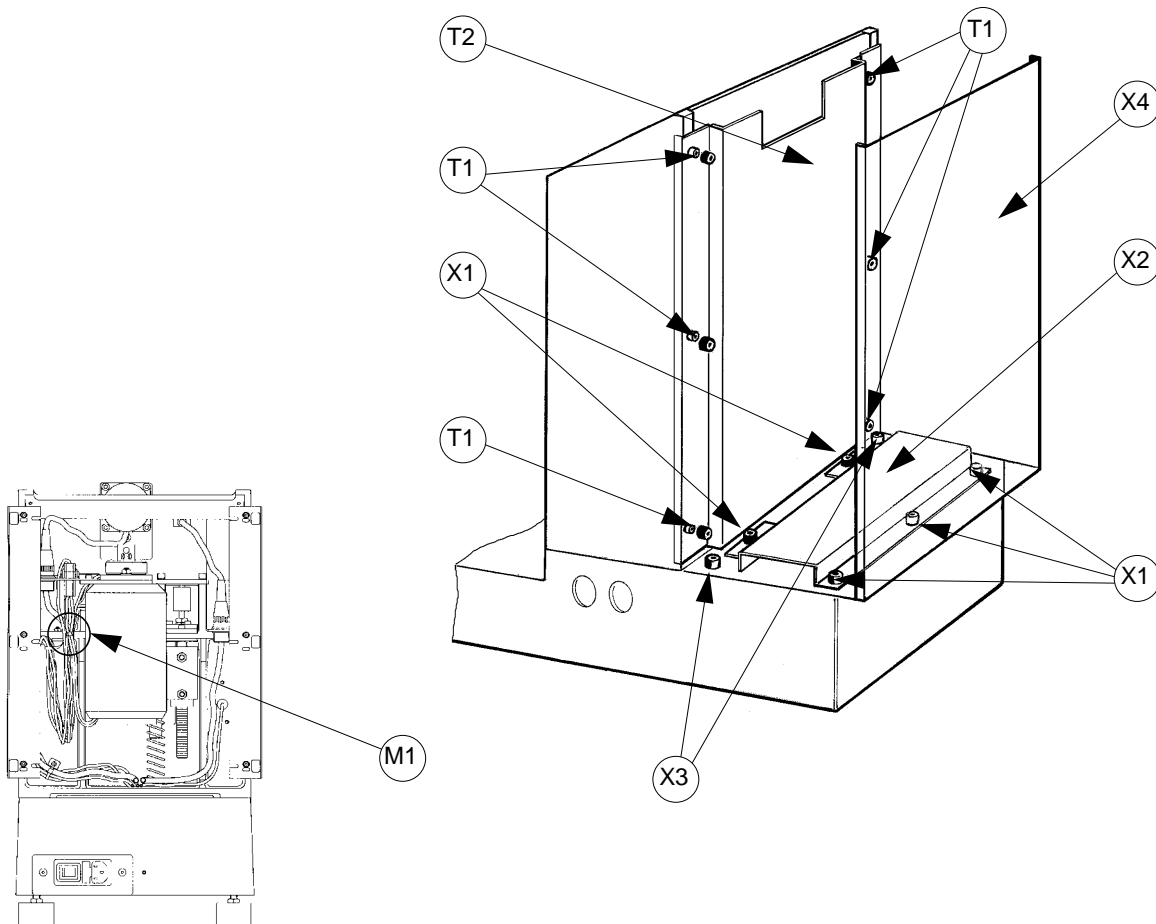

Fig. 47

9.14 Access to the electrical parts in the base

Access must be made when it is necessary to:

- replace the supply transformer.
- replace the zero board for the Y axis or its wiring.
- replace the commutation board for 1st/2nd speed for the cutting tool motor or its wiring.
- replace the cutting tool motor speed regulation board, change the setting or replace the wiring.
- replace the zero sensor for the Y axis.
- replace wiring.

To gain access to the base:

- 1) switch off the machine and disconnect the supply wire.
- 2) turn the machine onto its back.
- 3) loosen the six screws and remove the bottom plate (V3) (fig. 48).

WARNING: *If it is necessary to operate in this area with the machine on (e.g. to regulate a sensor or the 1st cutting tool rotation speed), take great care not to touch the parts of the 'cutting tool motor speed regulation board' as these are connected electrically to the supply phase (220 or 110 Volts).*

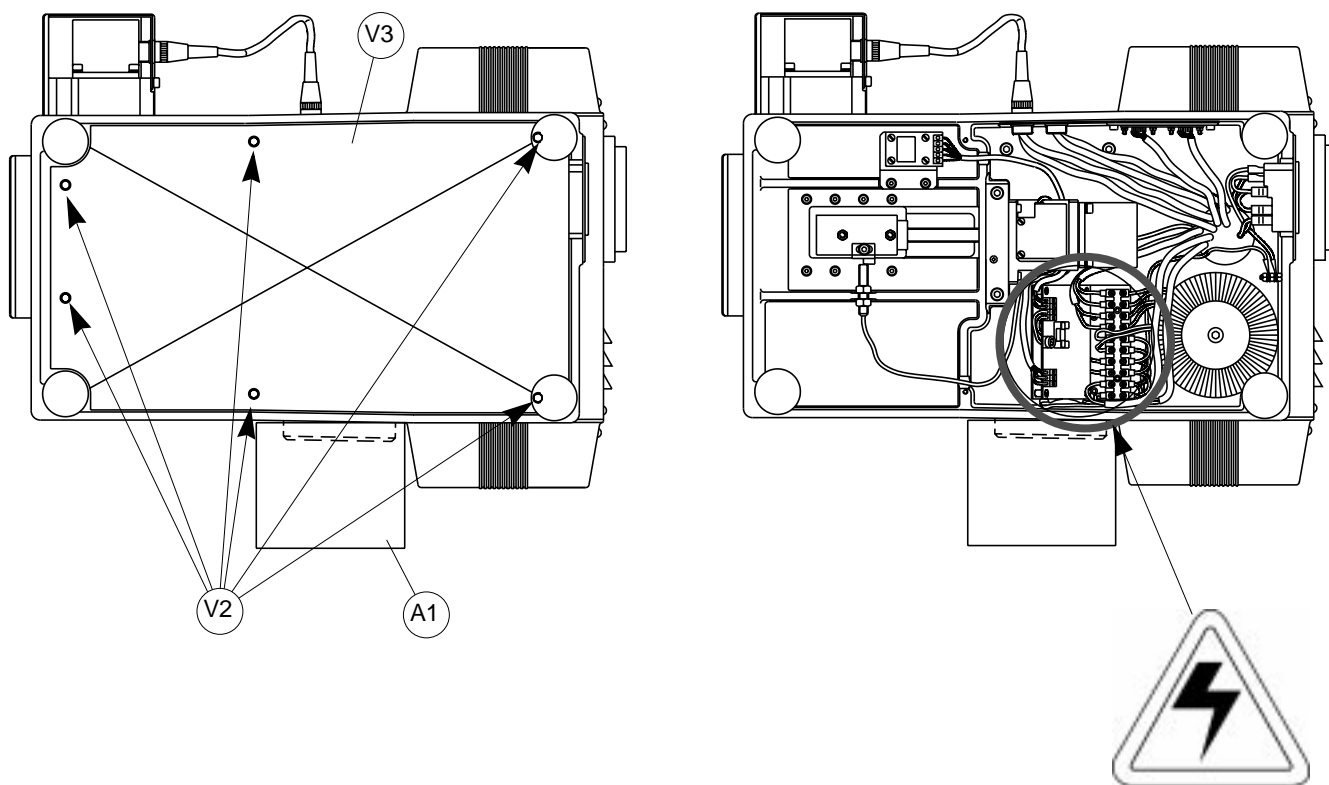

Fig. 48

10 DECOMMISSIONING

The machine is durable and when properly maintained and occasionally overhauled can be used throughout time.

Before dismantling carry out the following operations on the machine:

- Disconnect the electric circuit
- Separate the plastic and metal parts
- Remove the lithium battery from the electronic rack (fig. 49).

WARNING: *the lithium battery must be disposed of in the special containers.*

This done, dismantle the machine and dispose of the various parts according to the regulations in force in the country of use.

- **Waste disposal**

EU regulations lay down specific rules for the disposal of waste (**).

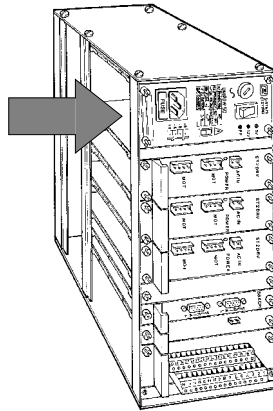

Fig. 49

Packing

The QUATTROCODE is delivered in a cardboard cover which can be recycled as packing, if intact, or disposed of with solid urban waste. Do not throw it out into the environment, but place it in the special containers for cardboard.

Key-cutting machine

The machine is not only durable, but is also made of recyclable materials. Recycling is recommended as good ecological practice.

Waste from key cutting operations

Although the waste deriving from key cutting is classified as special waste, it can be considered metal wool and therefore be included in solid urban waste. As such, it must be disposed of in special centres according to its classification under current Italian and EU law. In the case of contaminating or toxic-noxious substances which transform the metal waste classifiable as solid urban waste into toxic-noxious waste, the regulations concerning disposal of such waste in Italy and the EU are attached in the appendix to this manual.

11 AFTER-SALES SERVICE

Silca supplies full technical assistance to purchasers of the QUATTROCODE key-cutting machine. For total operator and machine safety, any operation not described in this manual must be carried out by the manufacturer or in the Service Centres recommended by Silca.

On the back of the manual cover are the manufacturer's addresses and a list of specialized Service Centres.

11.1 How to apply for assistance

The guarantee form supplied with the QUATTROCODE ensures free repairs or replacements of faulty parts in the 12 months following purchase. All other work must be arranged by the user with Silca or one of its Service Centres.

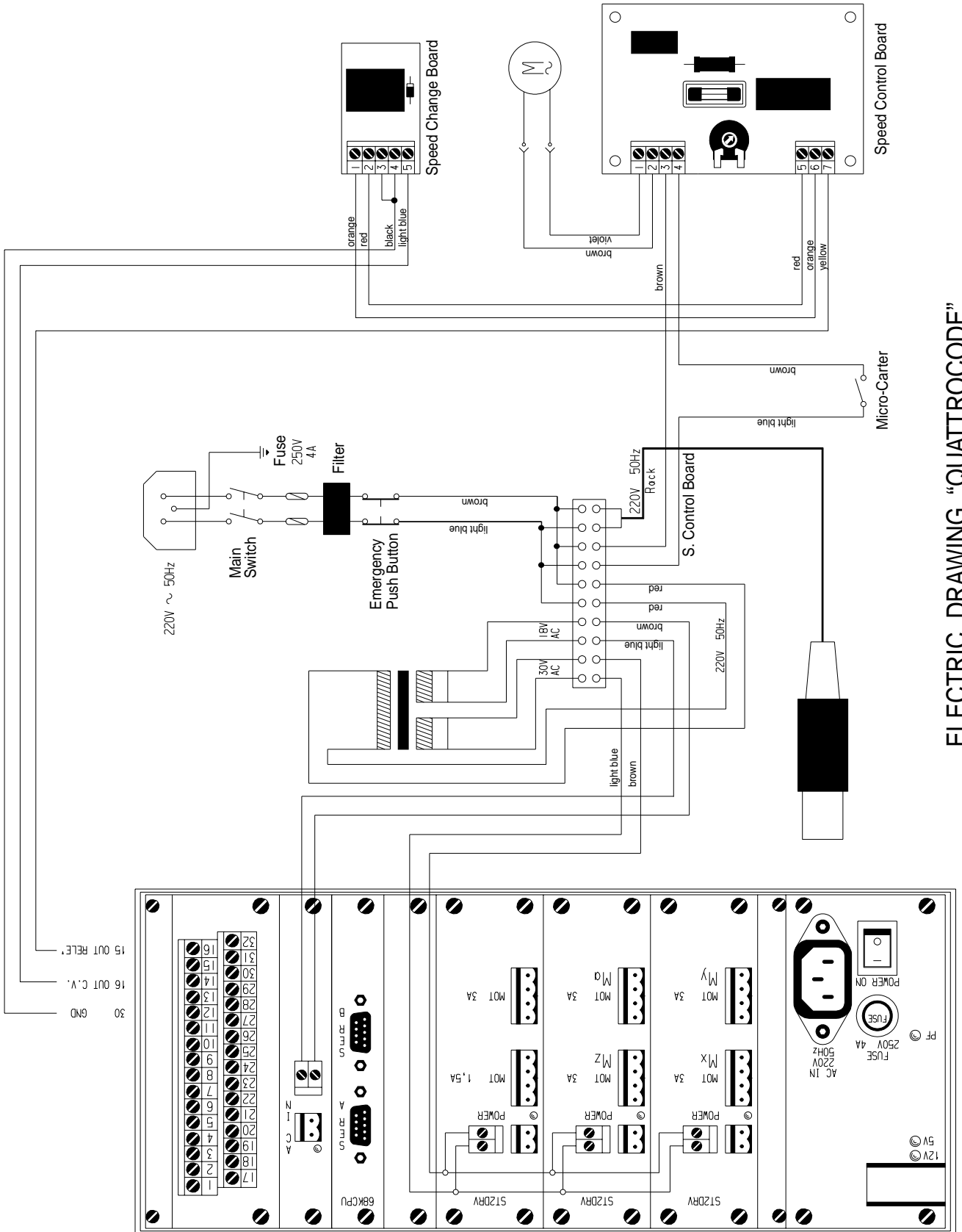

ELECTRIC DRAWING "QUATTROCODE"

Rack

ELECTRIC DRAWING "QUATTROCODE"

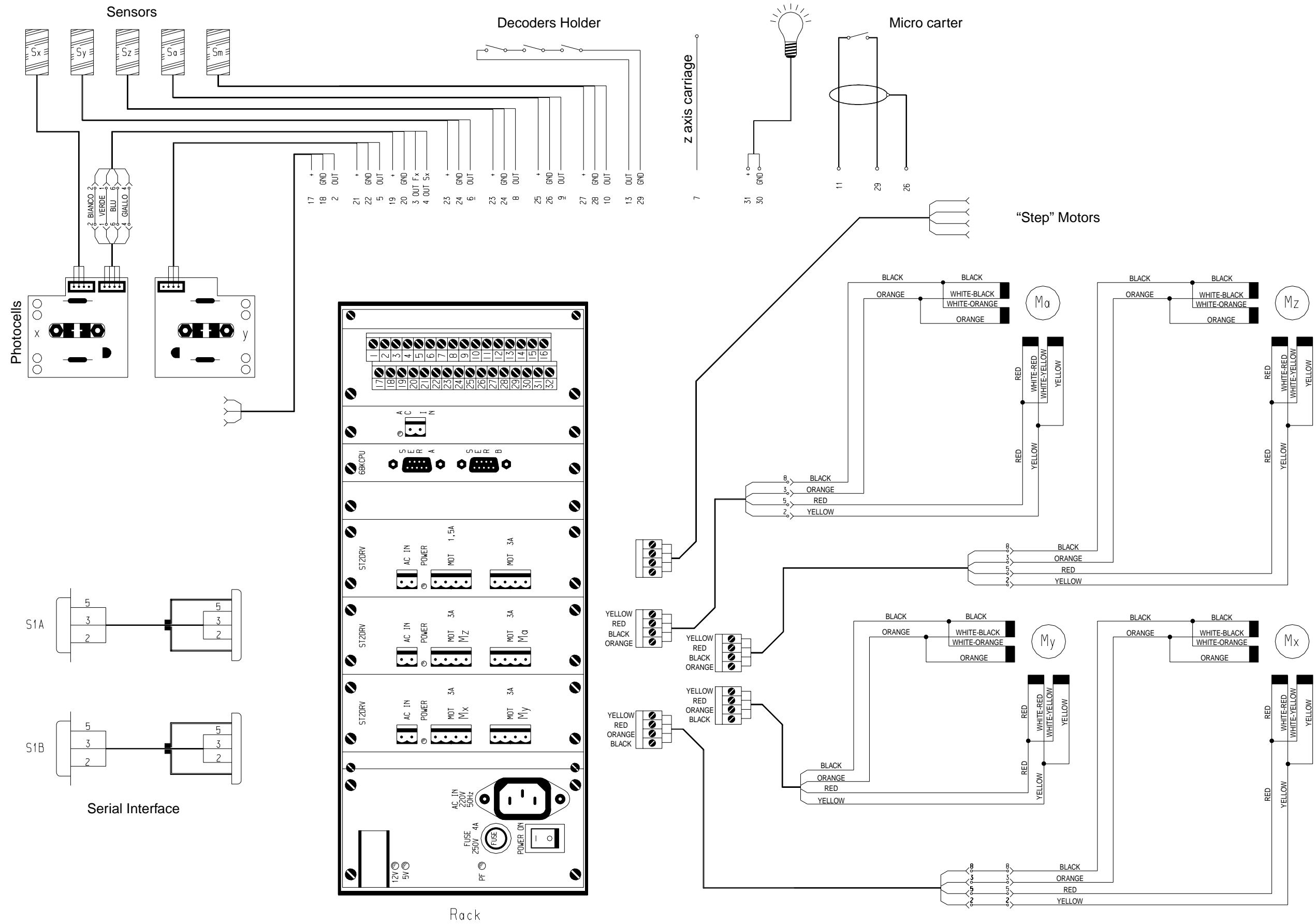



SILCA S.p.A.
Via Podgora, 20 (Z.I.) 31029 VITTORIO VENETO (TV)
Tel. 0438 9136 Fax 0438 913800
www.silca.it

Member of the Kaba Group

