

MATRIX

SX

Operating manual

D411774XA

vers. 1.1

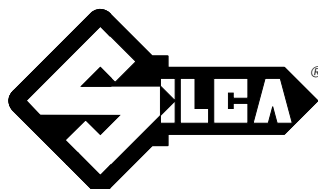

(c) 1994 SILCA S.p.A. - Vittorio Veneto

This manual has been drawn up by SILCA S.p.A.

All rights reserved. No part of this publication may be reproduced or used in any form or by any means (photocopying, microfilm or other) without the permission of SILCA S.p.A.

First published in July 1994

*Printed in Vittorio Veneto
by SILCA S.p.A.
via Podgora, 20 (Z.I.)
31029 VITTORIO VENETO (TV) - Italy*

CONTENTS

		Page
Chapter 1.	TRANSPORT	3
1.1	Packing	3
1.2	Transport	4
1.3	Opening the packing.....	4
1.4	Handling the machine.....	4
Chapter 2.	MACHINE DESCRIPTION	5-6
2.1	Working parts	7
2.2	Technical data.....	8
2.3	Graphics.....	8
2.4	Electrical circuit.....	9
Chapter 3.	ACCESSORIES PROVIDED	10
Chapter 4.	MACHINE INSTALLATION and PREPARATION	11
4.1	Checking for damage.....	11
4.2	Atmospheric conditions.....	11
4.3	Positioning	11
4.4	Description of work station	11
Chapter 5.	MACHINE REGULATION and REGISTRATION	12
5.1	Clamps	12
5.2	Spring system for LASER (sidewinder) type keys	13-14
5.3	Hand rest.....	15
5.4	Tracer point vertical spring system.....	15
5.5	Fitting and regulating the tools.....	16
5.6	Setting.....	17
5.7	Micrometric ring nut.....	18
Chapter 6.	CUTTING OPERATIONS	19
6.1	Fitting the keys	19
6.2	Key stop	19
6.3	CUTTING DIMPLE KEYS.....	20
6.3.1	Cutting the back	20
6.3.2	Inclined cuts	20
6.4	CUTTING LASER (SIDEWINDER) TYPE KEYS	21
6.5	CUTTING NARROW-STEMMED LASER (SIDEWINDER) TYPE KEYS	22
6.6	CUTTING KEYS for FICHET.....	23
Chapter 7.	MAINTENANCE	24
7.1	Replacing the belt and adjusting tension	24
7.2	Replacing the light bulb	25
7.3	Registration/replacement of the vertical carriage tension spring.....	25
7.4	Checking and replacing the fuses.....	26
7.5	Replacing the electronic board for the keypad.....	26
Chapter 8.	WASTE DISPOSAL	27
Chapter 9.	ASSISTANCE	27
9.1	How to request service	27

SAFETY DEVICE

The device is connected to a power plug with a differential switch. It activates the key-cutting machine when the illuminated ON button (B) is pressed and cuts out when the OFF button (C) is pressed.

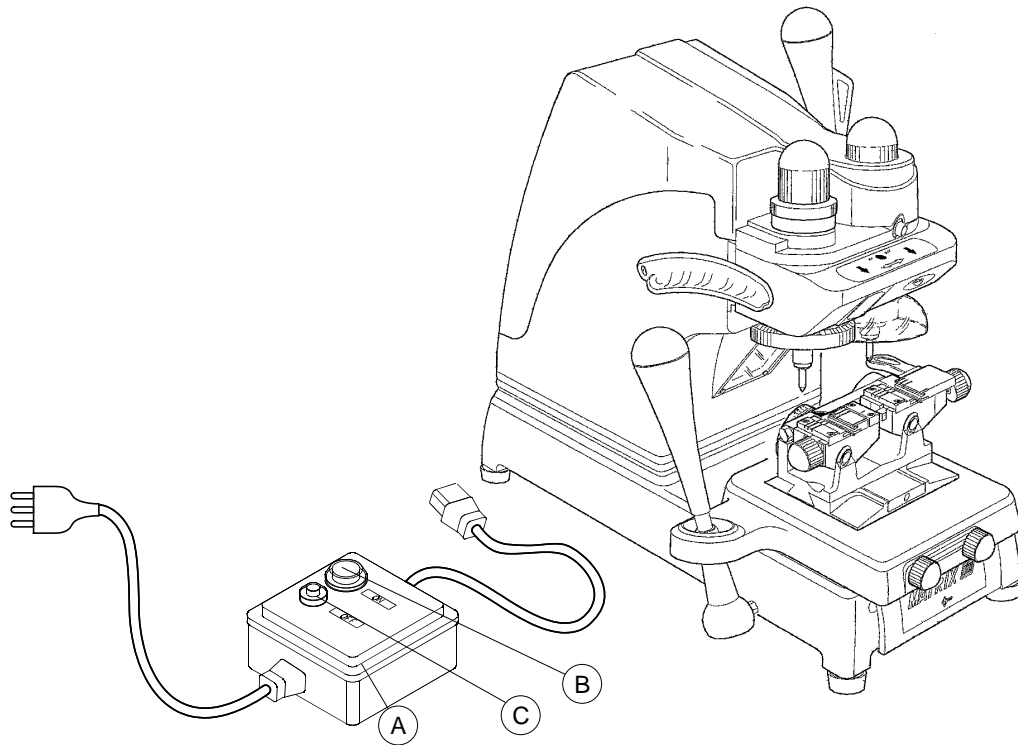

- A Safety device
- B ON button
- C OFF button

ELECTRICAL CIRCUIT

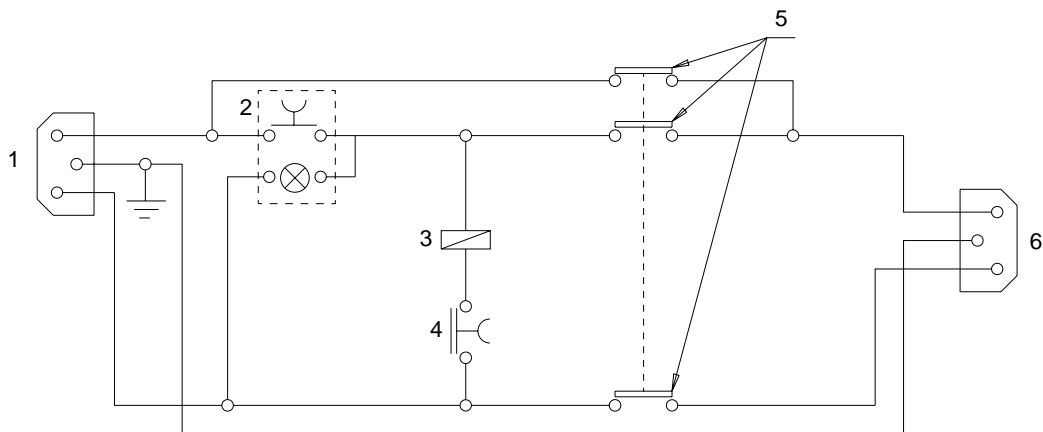

- 1) Safety device inlet
- 2) Illuminated ON button
- 3) 3 contacts relay, 220V a.c.
- 4) OFF button
- 5) Relay contacts
- 6) Safety device plug

MATRIX

USE of TOOLS PROVIDED - UTILIZZO degli UTENSILI IN DOTAZIONE
 GEBRAUCH DER WERKZEUGE - UTILISATION de les OUTILS EN DOTATION
 UTILIZACIÓN de los ÚTILES EN DOTACIÓN

MAIN BRAND MARCA MARKE MARQUE MARCA	SILCA KEYBLANK ARTICOLO SILCA SILCA-ARTIKEL ARTICLE SILCA ARTÍCULO SILCA	MACHINE MACCHINA MASCHINE MACHINE MÁQUINA	TRACER POINT TASTATORE TASTER PALPEUR PALPADOR	CUTTING TOOL FRESINO FRÄSER FRAISE FRESA		
ABUS (D)	AB40	SLX - SX - S	T1	D401070RA	F1	D701071ZB
AZBE (E) (CAVERS)	AZ6-AZ7	SLX - SX - S	T42	D408799RA	F42	D708800ZB
CISA (I)	CS48	SLX - SX - S	T1	D401070RA	F1	D701071ZB
DOM (D)	DM21 - DM55 - DM58	SLX - SX - S	T1	D401070RA	F1	D701071ZB
ELCA (D) TESA (E)	EC5	SLX - SX - S	T1	D401070RA	F1	D701071ZB
FICHET (F)	FT500	SLX - SX - S	T22	D405487RA	F22	D705488ZB
FTH (F) (YALTRES)	FH12	SLX - SX - S	T5	D401078RA	F5	D701079ZB
GE-GE (A)	GE57	SLX - SX - S	T1	D401070RA	F1	D701071ZB
GIOBERT (I) SAFE (I)	GT2P - GT2 - GT2BP (LANCIA) GT9AP - GT2AP (ALFA ROMEO) GT2CP	SLX - SX - S	T1	D401070RA	F1	D701071ZB
HONDA (J)	HON60AP (LEGEND)	SLX - SX - S	T44	D409147RA	F44	D709148ZB
HUF (D)	HU59 - HU58AP (BMW)	SLX - SX - S	T22	D405487RA	F22	D705488ZB
HUF (D)	HU44AP - HU41P HU61AP - HU55P HU40P - HU39P (MERCEDES)	SLX - SX - S	T22	D405487RA	F22	D705488ZB
HUF (D)	HU57RP - HU56RP (VOLVO)	SLX - SX - S	T22	D405487RA	F22	D705488ZB
HUF (D) YMOS (D)	HU43P - YM27P (OPEL-VAUXHALL)	SLX - SX - S	T22	D405487RA	F22	D705488ZB
KABA (CH)	KA1 - KA2 - KA3 KA4 - KA5 - KA6	SLX - SX - S	T1	D401070RA	F1	D701071ZB
KABA (CH)	KA2 - KA9	SLX - SX	T43	D408987RA	F43	D708988ZB
KESO (CH)	KE3 (82°)	SLX - SX - S	T26	D405654RA	F26	D705655ZB

MAIN BRAND MARCA MARKE MARQUE MARCA	SILCA KEYBLANK ARTICOLO SILCA SILCA-ARTIKEL ARTICLE SILCA ARTÍCULO SILCA	MACHINE MACCHINA MASCHINE MACHINE MÁQUINA	TRACER POINT TASTATORE TASTER PALPEUR PALPADOR		CUTTING TOOL FRESINO FRÄSER FRAISE FRESA	
MCM (E)	MC9	SLX - SX - S	T37	D406653RA	F37	D706654ZB
MCM (E)	MC9	SLX - SX - S	T38	D406656RA	F38	D706657ZB
MCM (E)	MC9	SLX - SX - S	T39	D406658RA	F39	D706659ZB
MCM (E)	MC10R + COPPIA ADATTATORI D711137ZB	SLX - SX - S	T50	D411145RA	F50	D711144ZB
MUL-T-LOCK (IL)	MTK1-MTK2P	SLX - SX - S SLX - SX - S	T12A T12B	D501090ZM D401092RA	F12A F12B	D701091ZB D701093ZB
NEIMAN (D)	NE67AP - NE66P - NE66 (VOLVO)	SLX - SX - S	T22	D405487RA	F22	D705488ZB
NISSAN (J)	NSN10AP - NSN10 - NSN9P (INFINITI)	SLX - SX - S	T22	D405487RA	F22	D705488ZB
SPIDER (IL)	SPR1 - SPR2	SLX - SX - S	T1	D401070RA	F1	D701071ZB
STS (E)	STS5-STS6	SLX - SX - S	T5	D401078RA	F5	D701079ZB
TESA (E)	TE4R	SLX - SX - S	T1	D401070RA	F1	D701071ZB
TESA (E)	TE7	SLX - SX	T5	D401078RA	F5	D701079ZB
TOYOTA (J)	TOY40 - TOY40AP - TOY40P (LEXUS)	SLX - SX - S	T22	D405487RA	F22	D705488ZB
YARD YARDENI (IL)	YD3R	SLX - SX - S	T1	D401070RA	F1	D701071ZB
YMOS (D)	YM30P (SAAB)	SLX - SX - S	T22	D405487RA	F22	D705488ZB
ZADI (I)	ZD20	SLX - SX - S	T5	D401078RA	F5	D701079ZB

GUIDE TO THE MANUAL

This manual has been produced to serve as a guide for users of the MATRIX SX key-cutting machine. Read it carefully; it is essential if you wish to operate your machine safely and efficiently.

Consultation

The contents of the manual are divided into sections relating to:

- Transport and handling Chapter 1
- Checking the safety of the machine Chapter 4
- Proper use of the machine Chapters 5-6
- Maintenance Chapter 7

Technical terms

Common technical terms are used in this manual.

Fig.1 shows the names of the different parts of the keys most commonly copied with the MATRIX SX.

Fig. 1

- 1) Head
- 2) Rim
- 3) Stop
- 4) Stem
- 5) Tip
- 6) Back
- 7) Cuts

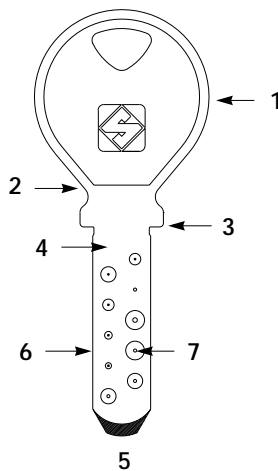

DIMPLE KEY

keys with holes of different dimensions, depths, positions and shapes.

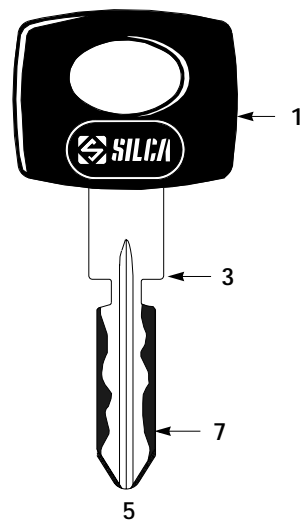

**LASER (SIDEWINDER)
TYPE KEY**

LASER is the name given to the special sidewinder milled keys.

GENERAL INSTRUCTIONS

The *MATRIX SX* key-cutting machine has been designed according to the specifications of the Machine Directives. Right from the design stage risks for the operator have been eliminated in all areas: transport, key-cutting, regulation and maintenance.

Other risks have been eliminated by the use of protective devices for the operator.

The protective devices used are designed not to provoke further risks and, above all, they cannot be ignored unless deliberately cut out. They do not hinder visibility of the work area.

A special adhesive label is attached to the machine warning the operator to use goggles during the cutting operations, and this is strongly recommended in this manual.

The material used in the manufacture of this machine and the components employed during use of the machine are not dangerous and their use complies with standards.

Use

The *MATRIX SX* must be installed and used in the way laid down by the manufacturer.

If the key-cutting machine is used differently or for purposes different from those described in this manual, the customer will forego any rights he may have over Silca S.p.A. Furthermore, unforeseen danger to the operator or any third parties may arise from incorrect use of the machine.

Negligence in the use of the machine or failure on the part of the operator to observe the instructions given in this manual are not covered by the guarantee and the manufacturer declines all responsibility in such cases.

It is therefore indispensable to read the operating manual carefully in order to make the best use of the *MATRIX SX* and benefit from its potential.

Further risks

There are no further risks arising from the use of the *MATRIX SX* key-cutting machine.

Protection and safety precautions for the operator

The *MATRIX SX* key-cutting machine is built entirely to standards. The operations for which it has been designed are easily carried out at no risk to the operator.

The adoption of general safety precautions (wearing protective goggles) and observation of the instructions provided by the manufacturer in this manual eliminate all human error, unless deliberate.

The *MATRIX SX* key-cutting machine is designed with features which make it completely safe in all its parts.

- **Power supply**

The machine is supplied with electricity by means of an earthed plug and differential switch.

- **Start-up**

The machine is started up by means of the master switch on the back.

- **Operations**

The motor start switch activates the cutting tool.

- **Illumination**

The work area is illuminated by a lamp which operates when the machine is switched on with the master switch.

- **Maintenance**

The operations to regulate, service, repair and clean the machine have been devised in the simplest possible way. There is no danger of removable parts being replaced wrongly or unsafely.

- **Machine identification**

The *MATRIX SX* key-cutting machine is provided with an identification label which shows the serial number (Fig.2).

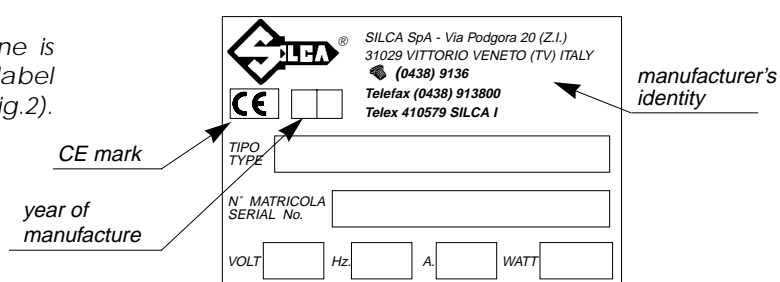

Fig. 2

1. TRANSPORT

The MATRIX SX key-cutting machine is easily transported and is not dangerous to handle. The packed machine can be carried by one person.

1.1 Packing

The packing used for the MATRIX SX guarantees that the machine will travel safely without danger of damage to it or its components.

The packing comprises two shells, (a) lower and (b) upper and 2 supports (c) in expanded plastic in the machine is wrapped (Fig.3).

A strong outer cardboard box, the measurements of which can be seen in Fig.3a, and the plastic wrapping protect the machine even over a long period of storage.

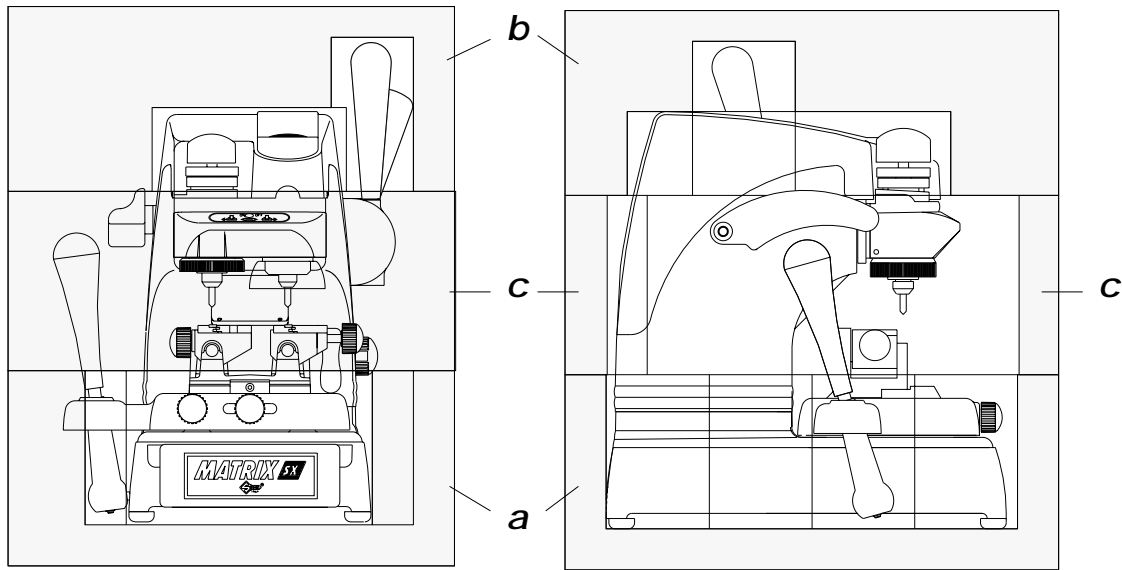

Fig. 3

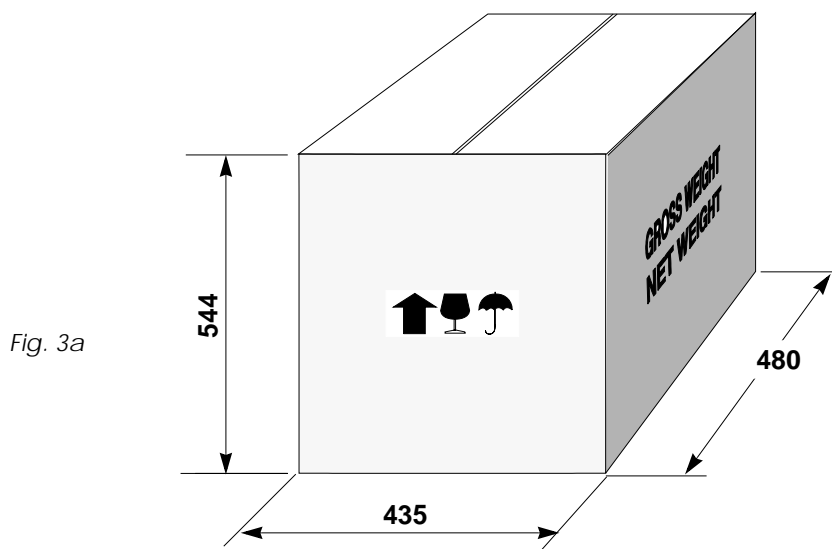

Fig. 3a

1.2 Transport

The symbols on the outside of the packing box show the ideal conditions for transport. Use of the packing box whenever the machine is transported will avoid knocks or bumps which could cause damage.

1.3 Opening the packing

To remove the machine from the packing box:

1. cut the straps with scissors and remove.
2. prise off the staples.
3. open the box without damaging it as it may be used again (removals, despatch to the manufacturers for repairs or servicing).
4. check the contents of the box, which should comprise:
 - 1 MATRIX SX key-cutting machine packed in a protective shell.
 - 1 set of documents including: operating manual, spare parts list and guarantee.
 - 1 connecting wire.
5. remove the key-cutting machine from the protective shell.

1.4 Handling the machine

When the MATRIX SX has been unpacked, place it directly on its workbench.

This operation can be carried out by one person, **firmly holding the base, and no other part, to lift and carry the machine.**

2. MACHINE DESCRIPTION

The MATRIX SX is an excellent quality, high precision key-cutting machine. It features great versatility in cutting keys of different types without the need to replace the clamp or apply fixed adapters.

MATRIX SX cuts the following types of keys:

- **dimple keys** (with flat or inclined cuts)
- **Laser (sidewinder) type keys**
- **keys for Fichet**

dimple keys

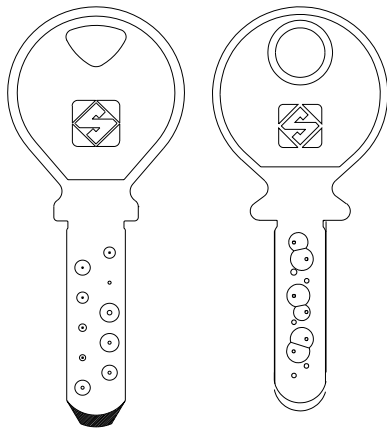

Laser (sidewinder) type keys



keys for Fichet *

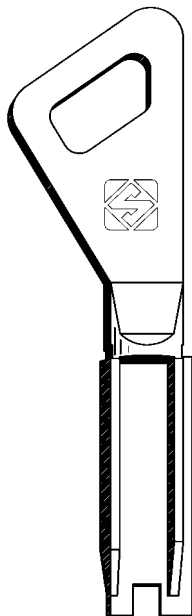

Laser narrow-stemmed (sidewinder) type keys *



(*) ADAPTERS PROVIDED

High precision work is guaranteed by the combination of the functional features on the MATRIX SX and all its components, such as:

- **MOVEMENTS**

The three axes move on ball guides which provide smooth running and easy sliding without play.

- **CLAMPS**

The MATRIX SX is provided with balancing, interchangeable clamps.

The pair of jaws can be inclined from 0 to $\pm 45^\circ$ and all intermediate positions, according to the key to be cut.

- **SPRING SYSTEM FOR LASER (SIDERWIDER) KEYS**

The machine is provided with a system which controls the run of the cross axis so that the operator can easily trace the outline of the cuts along the key shaft.

- **ELECTROMECHANICAL SETTING**

A precision electromechanical system ensures centesimal regulation of settings, made easier and quicker by the warning lights on the machine key pad.

- **PROTECTIVE SHIELD**

A special transparent plastic shield prevents chippings from flying into the air.

- **LAMP**

Placed directly on the machine, it illuminates the work area.

- **TRACER POINT SPRING SYSTEM**

This system guides and facilitates self-centering of the cuts on dimple keys.

It is activated or deactivated by simply turning the ring nut.

- **CENTESIMAL MICROMETRIC RING NUT**

Ensures perfect depth alignment of the tools and makes it possible to adjust for defects on worn keys with minute, controllable depth variations ($\pm 0,02$ mm).

- **LEVERS AND KNOBS**

Each lever and knob has been designed with dimensions, materials and positions which render grip and movement extremely simple.

Materials and finish have been chosen according to the use of each part, especially:

lever (I) for vertical carriage (Z axis)

ergonomic and provided with a locking mechanism which allows registration of the height of the cutter assembly from the cutting surface, adapting this to the key (especially useful when cutting Laser (sidewinder) keys) without a need for the operator.

lever (C) X-Y axes

the lever which guides movement along the X-Y axes is ergonomic and makes precise, sensitive movements due to a special joint with ball articulation and slide on ball guides.

hand rest (R)

the movement of the cutting tool along the cuts for both Laser (sidewinder) and dimple keys is facilitated by an adjustable hand rest which guarantees smooth, synchronised carriage movements during the cutting operations.

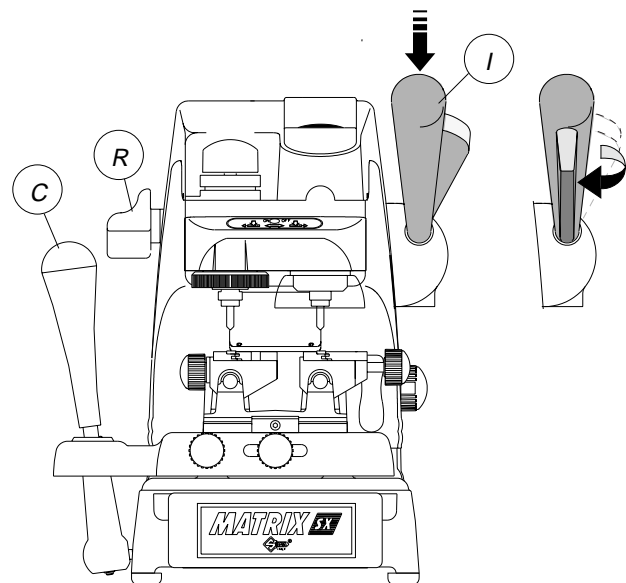

Fig. 4

2.1 Working parts

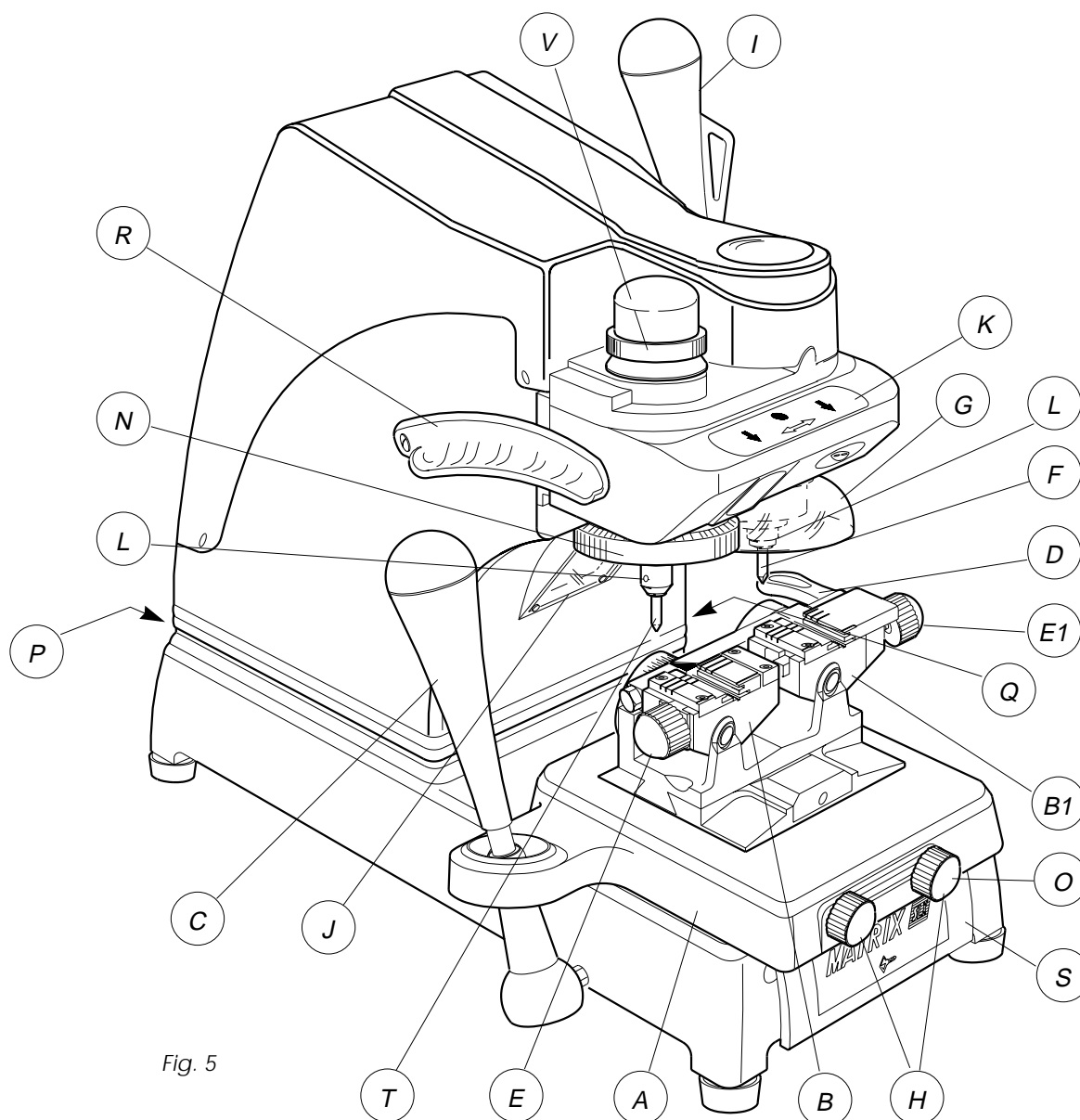

Fig. 5

- | | |
|---|---|
| A - clamp carriage (X-Y axes) | L - sleeve (cutting tool and tracer point holder) |
| B - left-hand balancing jaw | N - micrometric ring nut for regulating tracer point |
| B1 - right-hand balancing jaw | O - regulating knob for Laser (sidewinder) key spring system |
| C - clamp carriage lever (X-Y axes) | P - master switch |
| D - jaw balancing locking lever (X-Y axes) | Q - motor start switch |
| E - left-hand jaw knob | R - hand rest (left hand) |
| E1 - right-hand jaw knob | S - tool drawer |
| F - cutting tool | T - tracer point |
| G - protective shield | V - tracer point spring system ring nut for dimple keys |
| H - Clamp carriage locking knobs | |
| I - vertical carriage lever (Z axis) | |
| J - lamp | |
| K - setting unit keypad | |

2.2 Technical data

MOTOR:	One-speed single phase 230 V-50 Hz (other voltages on request)
CUTTING TOOL:	Super rapid steel
CUTTER SPEED:	6000 rpm
MOVEMENTS:	on three axes by ball guides
CLAMP:	balancing with sliding jaws and interchangeable plates
RUNS:	X axis: 40 mm Y axis: 50 mm Z axis: 30 mm
ILLUMINATION:	25W incandescent lamp
DIMENSIONS:	width: 350 mm depth: 400 mm height: 470 mm
WEIGHT:	21,5 Kg
SOUND PRESSURE:	$L_p (A) = 76,3 \text{ dB (A)}$

2.3 Graphics

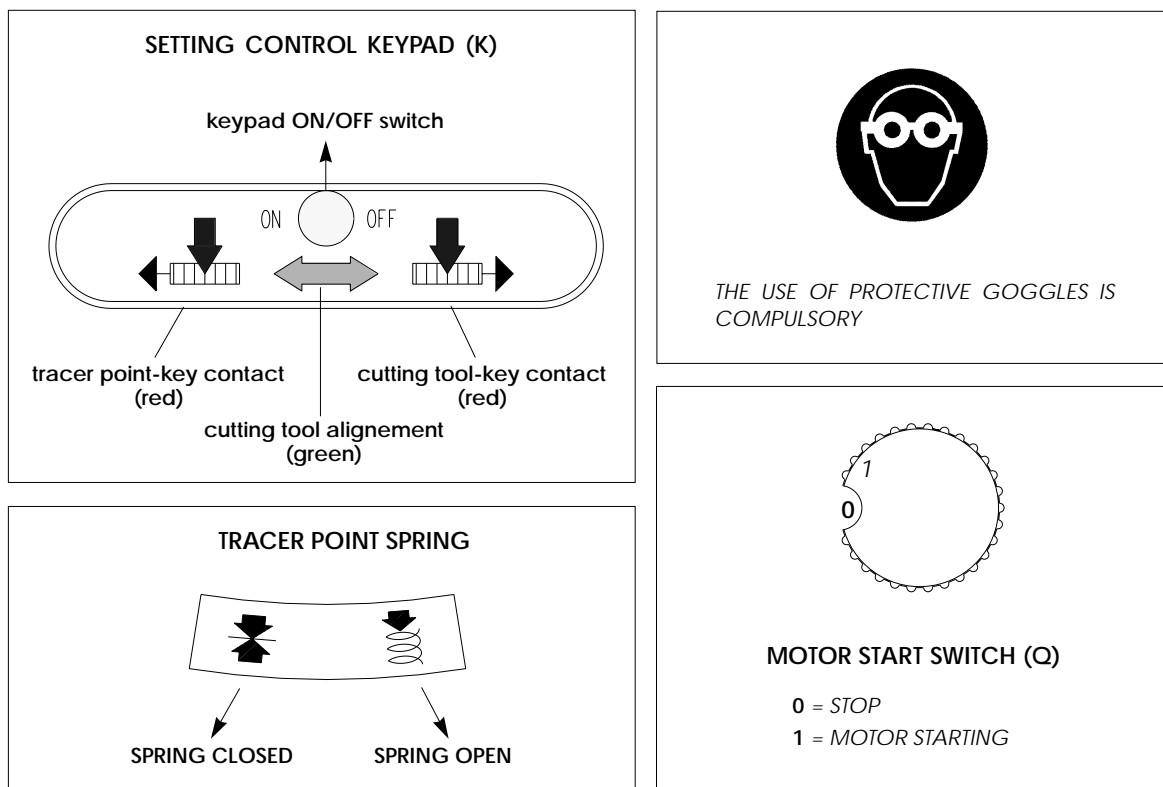

2.4 Electrical circuit

The main parts of the electrical and electronic circuit on the MATRIX SX are listed below:

- ① **Mains inlet:**
houses the master switch, the suppressor which protects the machine from interference in the mains supply and the two rapid fuses which protect the two phases from short circuits.
- ② **Central terminal board:**
for the connection of the electrical and electronic parts.
- ③ **Transformer:**
supplies power to the electronic board and led warning lights on the setting keypad.
- ④ **Motor switch:**
activates the motor.
- ⑤ **Motor:**
single phase brush motor.
- ⑥ **Lamp:**
illuminates the work area.
- ⑦ **Electronic board for setting control:**
the board is powered at low voltage from the transformer (3) and is connected electrically to the clamps (8), tracer point (9) and cutting tool (10). It signals the correct setting by illuminating the relevant leds.

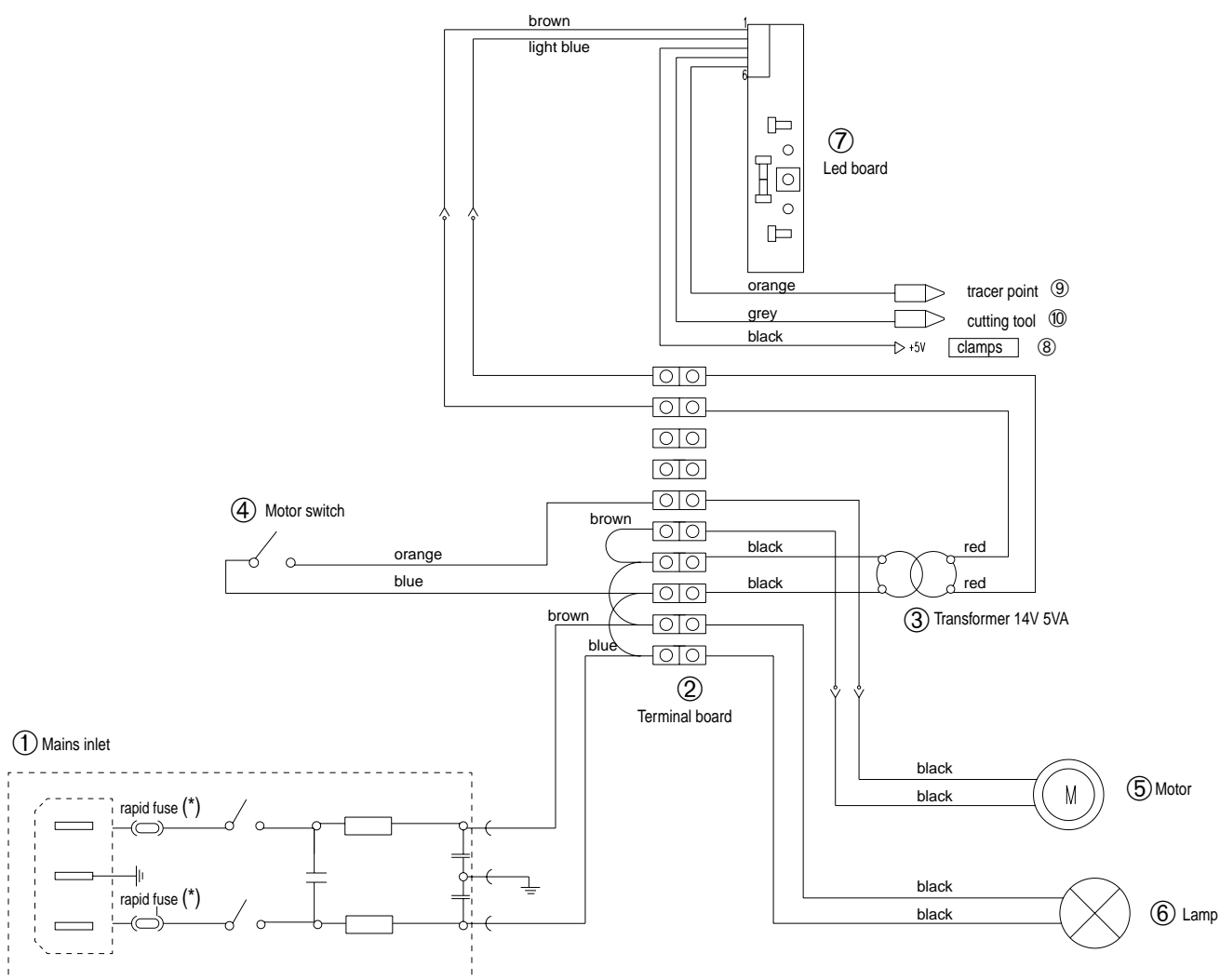

(*) 3,15 Amps for 115V
2 Amps for 230V

3. ACCESSORIES PROVIDED

A set of accessories is supplied for use with the machine or for servicing (tools, Allen keys and adapters).

The accessories are housed in a special drawer in the base of the machine (S) (Fig.5 - Fig.7) and include:

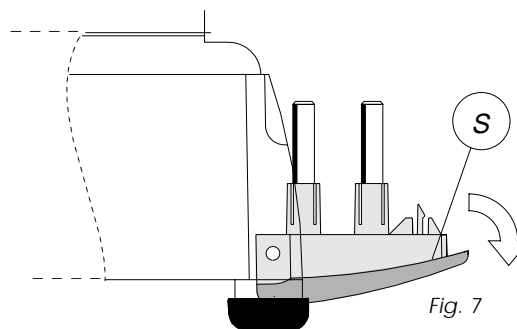
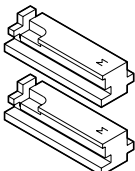
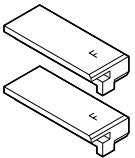

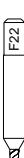
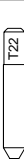



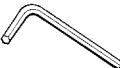

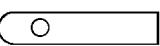
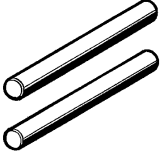



Fig. 7

<p>1</p> 	<p><i>code</i> D410533BA ADAPTER for narrow stemmed keys 2 pcs</p>	<p>2</p> 	<p><i>code</i> D410534BA ADAPTERS for keys for FICHET 2 pcs</p>	<p>3</p> 	<p><i>code</i> D701071ZB F1 CUTTING TOOL for dimple keys</p>	<p>4</p> 	<p><i>code</i> D401070RA T1 TRACER POINT for dimple keys</p>	<p>5</p> 	<p><i>code</i> D705488ZB F22 CUTTING TOOL for Laser (sidewinder) keys</p>	<p>6</p> 	<p><i>code</i> D405487RA T22 TRACER POINT for Laser (sidewinder) keys</p>	<p>7</p> 	<p><i>code</i> D705655ZB F26 CUTTING TOOL for dimple keys</p>	<p>8</p> 	<p><i>code</i> D405654RA T26 TRACER POINT for dimple keys</p>	<p>9</p> 	<p><i>code</i> D708988ZB F43 CUTTING TOOL for dimple keys with inclined cuts</p>	<p>10</p> 	<p><i>code</i> D408987RA T43 TRACER POINT for dimple keys with inclined cuts</p>	<p>11</p> 	<p><i>code</i> D300222ZZ 2,5 mm ALLEN KEY</p>	<p>12</p> 	<p><i>code</i> D400224ZZ 4 mm ALLEN KEY 2 pcs</p>	<p>13</p> 	<p><i>code</i> D402302BA STEEL TIP STOP BAR 1 pc</p>	<p>14</p> 	<p><i>code</i> D402903RA TESTING PIN 2 pcs</p>	<p>15</p> 	<p>FUSE (2 pcs) <i>code</i> D310757ZZ 2 Amps rapid for 230V <i>code</i> D309226ZZ 3,15 Amps rapid for 115V</p>
---	---	---	--	--	---	---	---	---	--	---	--	---	--	---	--	---	---	--	---	---	--	---	--	---	---	---	---	--	---

4 MACHINE INSTALLATION and PREPARATION

The key-cutting machine can be installed by the purchaser and does not require any special skills.

The machine is supplied ready for use and does not need to be set up, except when changing to different tools. However, some checks and preparation for use need to be carried out by the operator.

4.1 Checking for damage

The MATRIX SX key-cutting machine is solid and compact and will not normally damage if transport, unpacking and installation have all been carried out according to instructions. Notwithstanding, it is always advisable to check that the machine has not suffered any damage.

4.2 Atmospheric conditions

To ensure that the best use is made of the MATRIX SX key-cutting machine, certain parameters must be borne in mind:

*damp, badly ventilated sites should be avoided;
the ideal conditions for the machine are:*

temperature: from 0 to 40°C

relative humidity: approx. 60%

4.3 Positioning

Place the key-cutting machine on a horizontal surface, solid enough to take the weight. The workbench should be approx. 100-120 cm high to give easy access to the working parts of the machine.

Leave enough space around the machine (20-30 cm) to ensure good ventilation and room for manoeuvre.

- ▲ Ensure that the key-cutting machine voltage is suitable for the mains supply available, which must be earthed and provided with a differential switch.**

4.4 Description of work station

The key-cutting machine needs only one operator, who has the following controls at his/her disposal:

- *master switch (P) placed on the back of the machine.*
- *motor start switch (Q) (on the right-hand side of the machine).*
- *tool setting keypad (K).*
- *levers: lever (C) to move the clamp carriage
lever (I) to move the vertical carriage*

N.B.: the letters in brackets refer to Fig.5 on page 7.

5 MACHINE REGULATION and REGISTRATION

Before carrying out cutting operations the clamps and tools should be regulated according to the type of key to be cut and the spring systems which facilitate cutting operations must be activated or deactivated:

- the cross spring for Laser (sidewinder) keys.
- the vertical tracer point spring for dimple keys.

5.1 Clamps

The clamps are provided with special **key-locking jaws** (B4) and (B5) which can be easily changed if damaged, without replacing the whole clamp unit.

REGISTRATION:

Before starting cutting operations it is advisable to check that the clamps are in the horizontal position (reference 0) (Fig.8).

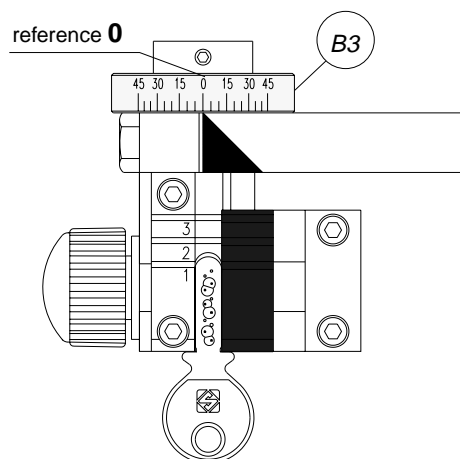
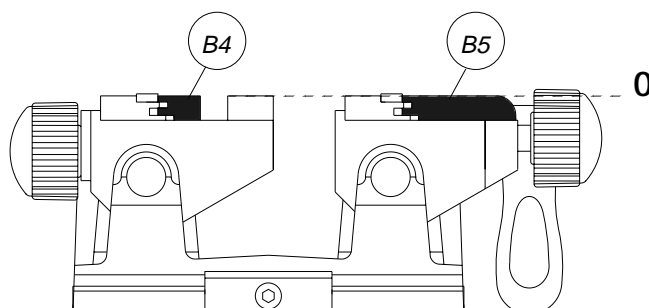

Fig. 8

To register the clamps on the different angles required when cutting keys with inclined cuts, proceed as follows:

- loosen the lever (D) locking the clamp unit (Fig.9).
- position the clamp at the angle required (B3) (see index on the graduated drum) (Fig.8).
- lock the lever (D).

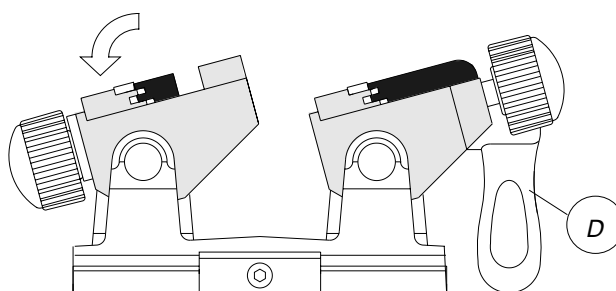
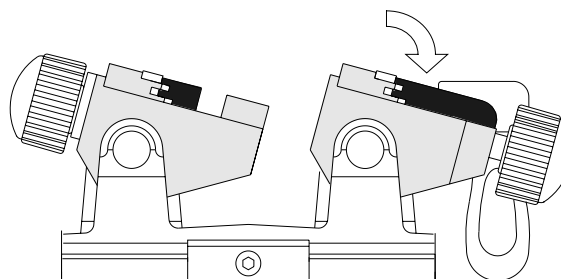

Fig. 9



5.2 Spring system for LASER (sidewinder) type keys

The clamp carriage on the MATRIX SX key-cutting machine is provided with a spring system which controls the range of trasversal movements, greatly assisting the cutting of Laser (sidewinder) keys.

The spring system for Laser (sidewinder) keys is activated by means of the knob (O) (Fig.10). It determines lateral pressure on the part of the tools throughout the cutting operation; this makes it possible for the operator to follow the outline of the cuts manually without having to exert cross pressure on lever (C).

Figs. 10, 11 and 12 shows three examples of the use of the spring system:

- 1** central cutting **2** right-hand cutting **3** left-hand cutting

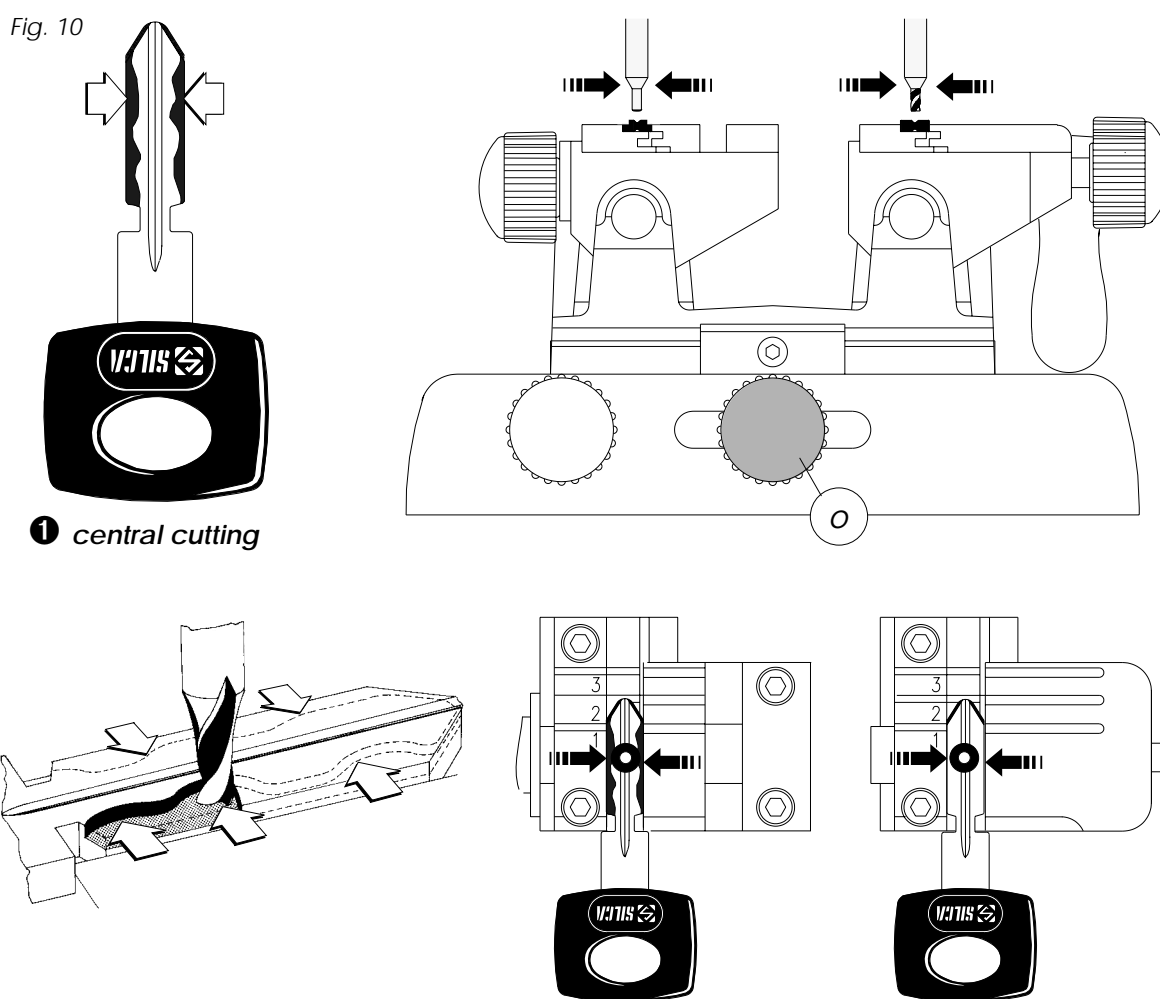

REGULATING THE SPRING

- Loosen knob (O) slightly.

- 1 central cutting:**
take the cutter and tracer over the centre of the stems of the two keys (Fig.10).
 - 2 right-hand cutting:**
take the cutter and tracer over the keys, positioning them to the left of the stems (Fig.11).
 - 3 left-hand cutting:**
take the cutter and tracer over the keys, positioning them to the right of the stems (Fig.12).
- Tighten knob (O) and carry out cutting operations.

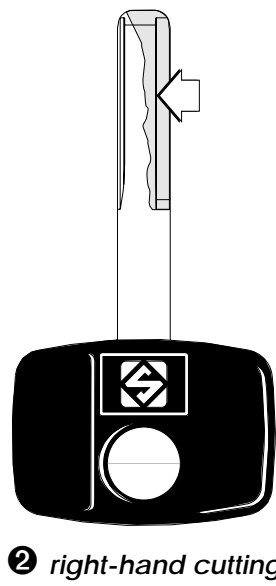

2 right-hand cutting

Fig. 11

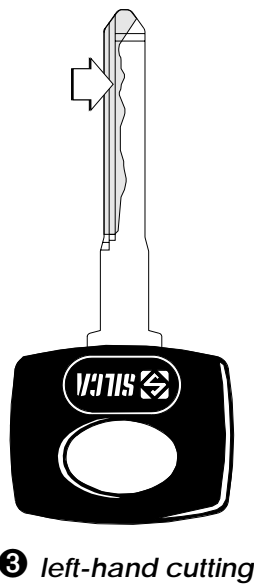
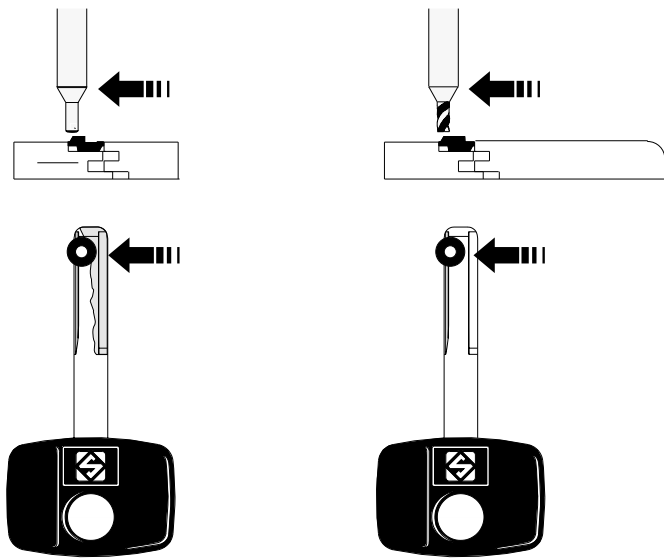

3 left-hand cutting

Fig. 12

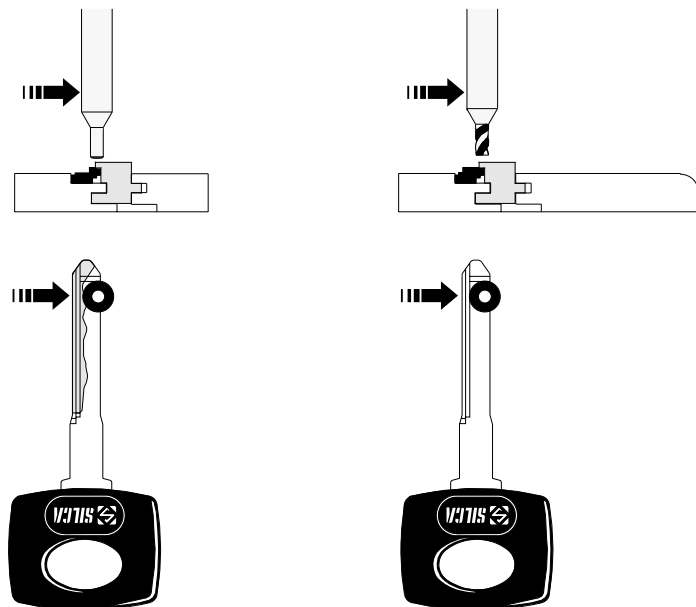

5.3 Hand rest

The hand rest (R) on the left-hand side of the machine must be regulated by the operator to his/her hand size. To regulate the position of the hand rest, proceed as follows:

- loosen the grub screw (R1) (Fig.13).
- turn the hand rest and ring nut (R2) simultaneously to the required position.
- tighten the grub screw (R1).

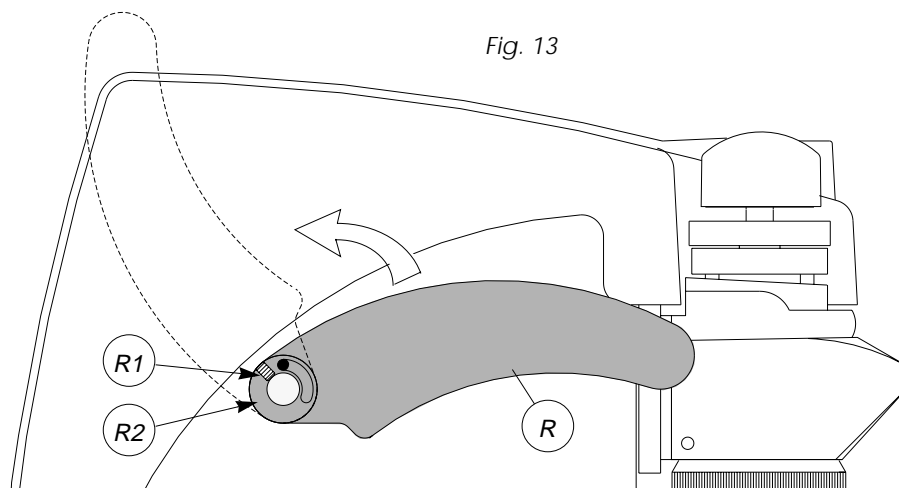

Fig. 13

5.4 Tracer point vertical spring system

- ▲ The tracer point spring system must be activated for cutting dimple keys only.

To activate the spring system:

turn the ring nut (V) anti-clockwise so that reference notch (V1) is aligned with the spring mark (Fig.14); a click will indicate that the spring system is activated.

To deactivate the spring system:

raise the tracer point assembly with one hand and in this position turn the ring nut (V) clockwise until the reference notch (V1) is aligned with the symbol for a closed spring (Fig.14a).

- ▲ **WARNING:** the spring system must always be activated after the tools have been aligned with the electromechanical device (ch.5.6).

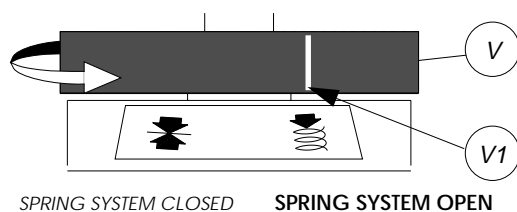

Fig. 14

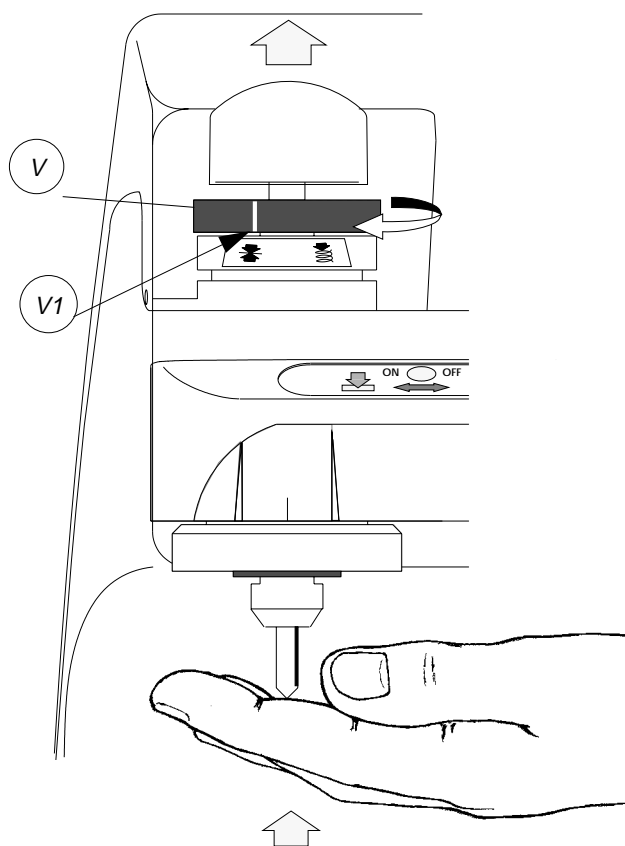

Fig. 14a

5.5 Fitting and regulating the tools

▲ **WARNING:** make sure that the motor start switch (Q) is in "0" position (STOP).

Switch on the machine with the master switch.

Make sure that the tracer point spring system is locked (ch.5.4).

Select the tools for the key to be cut and proceed as follows:

1. place the tracer point all the way into the left-hand sleeve and secure by tightening the grub screw (M) (Fig.15-15a).
2. place the cutting tool all the way into the right-hand sleeve and secure by tightening the grub screw (M1).

Releasing the tools

Unscrew the grub screw (M) and (M1) to remove the tracer point and cutting tool from the sleeves.

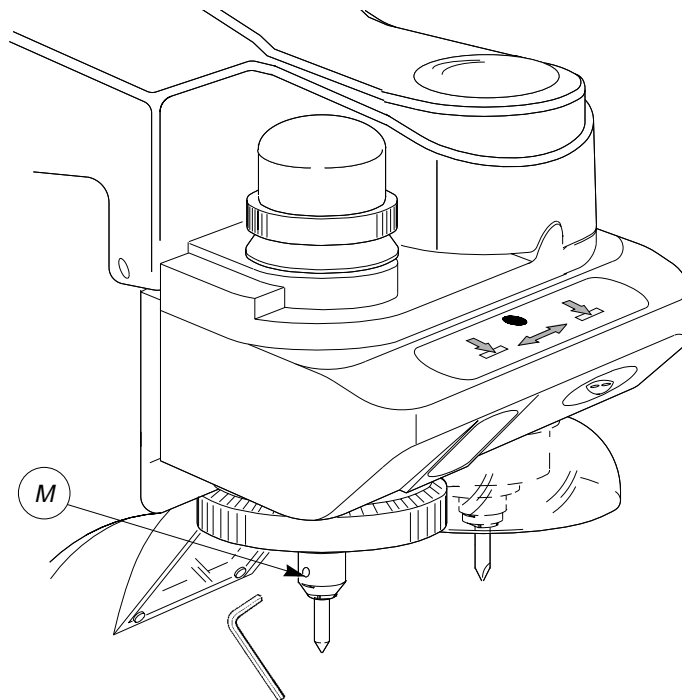

Fig. 15

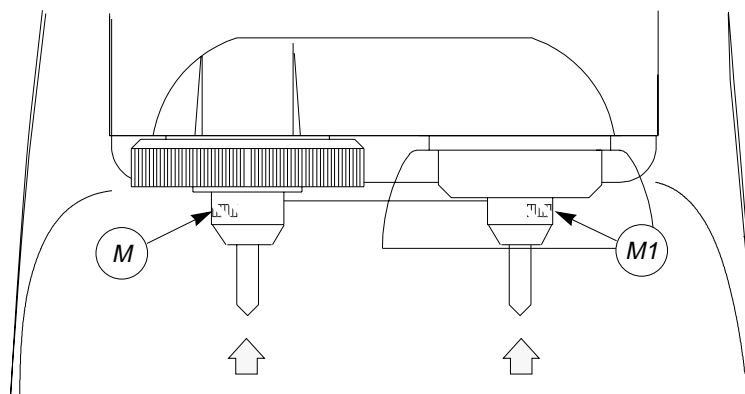

Fig. 15a

5.6 Setting

Place the keys into the clamps (the original in the left-hand jaw and the keyblank in the right-hand jaw) and turn on the machine with the master switch.

Set up the tools (ch.5.5).

Activate the electromechanical setting checker by striking the ON/OFF switch on the keypad (K) and start setting operations:

- lower the vertical carriage and rest the tools lightly on an uncut part of the keys.
- when the tools come into contact with the keys, one of the three warning lights will illuminate:
(K1 - green), (K2 - red) or (K3 - red) (Fig.16).

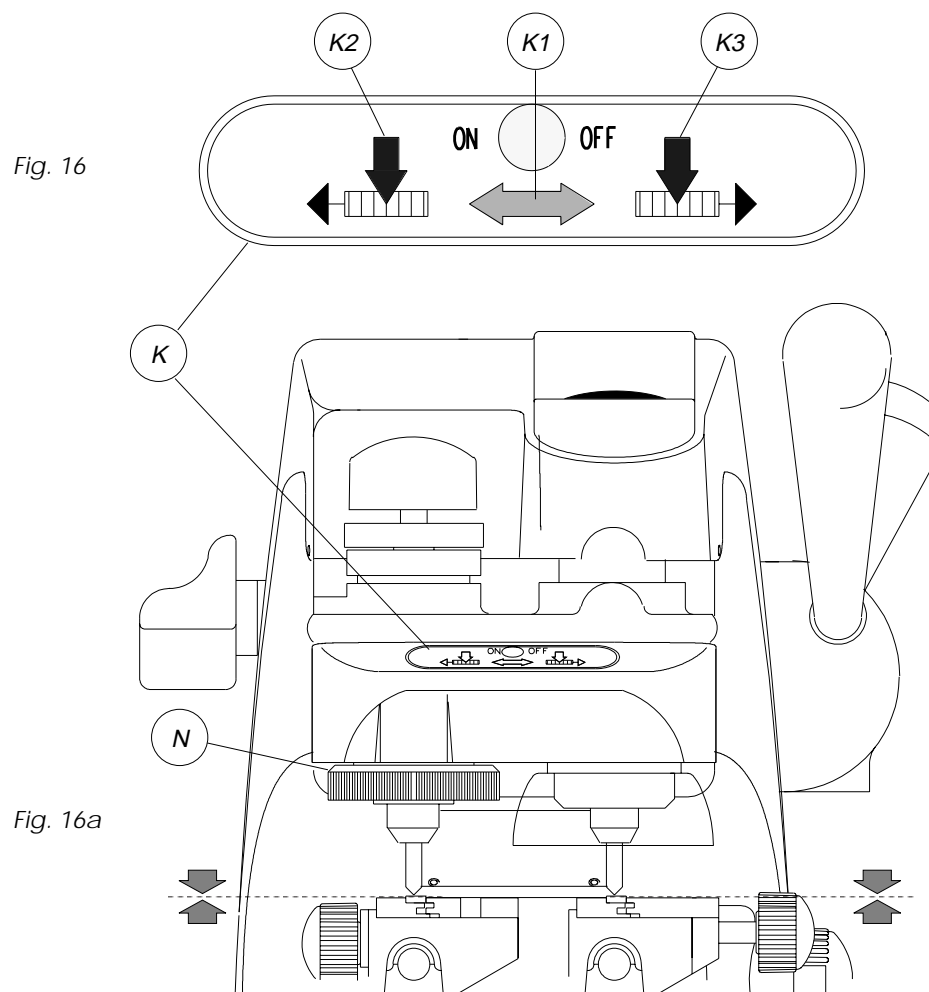

illumination of the green arrow (K1):

- the tools are aligned and do not need regulating.

illumination of the red arrow (K2):

- only the tracer point is in contact with the key;
turn the micrometric ring nut (N) clockwise (as shown) until the green arrow (K1) illuminates to show that the tools are aligned.

illumination of the red arrow (K3):

- only the cutting tool is in contact with the key;
turn the micrometric ring nut (N) anti-clockwise (as shown) until the green arrow (K1) illuminates to show that both tools are aligned.

5.7 Micrometric ring nut

The micrometric ring nut not only assists alignment of the tools, but it can also be used to correct the small depth variations found on worn keys.

After aligning the tools (green arrow K1) the depths of the cuts can be increased or reduced by turning the micrometric ring nut (N) to the right or left.

Each notch on the ring nut corresponds to an increase of 0,02 mm.

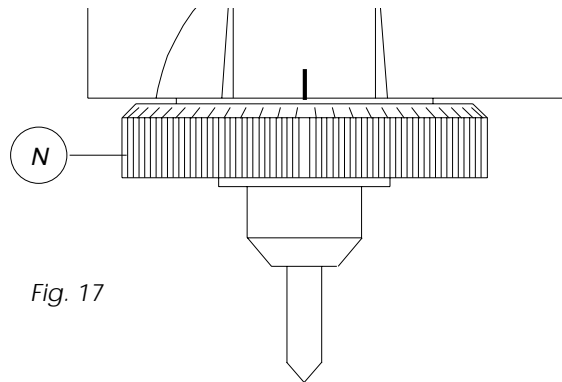

Fig. 17

6. CUTTING OPERATIONS

- ▲ For complete safety during the cutting operations, take the following precautions:
 - Always work with dry hands.
 - Check that the machine is properly earthed.
 - Wear protective goggles even if the machine is provided with a safety shield over the cutting tool.
 - Before starting the motor (switch Q), carry out the following operations:
 - a) place the keys in the clamps b) install the tools and gauge them.
 - Keep hands away from the cutting tool in motion.

6.1 Fitting the keys

- Switch on the machine with the master switch on the back.
- Take the clamp carriage towards the operator until it meets the end of run.
- Place the original key into the left-hand jaw and the keyblank into the right-hand jaw, paying attention to the type of stop on the key (ch.6.2).

6.2 Key stop

The references 0-1-2-3 on the clamps should be used according to the type of stop on the key:

0: for keys with rear stop (see Fig.18).

1-2-3: for keys with tip stop (Fig.18a)

Stops 1 - 2 - 3 are selected according to the length of the key stem.

▲ **WARNING:** the cutting run must always be confined within the surface of the clamp.

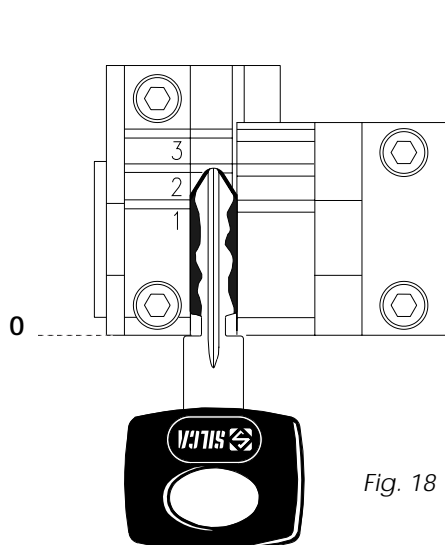

Fig. 18

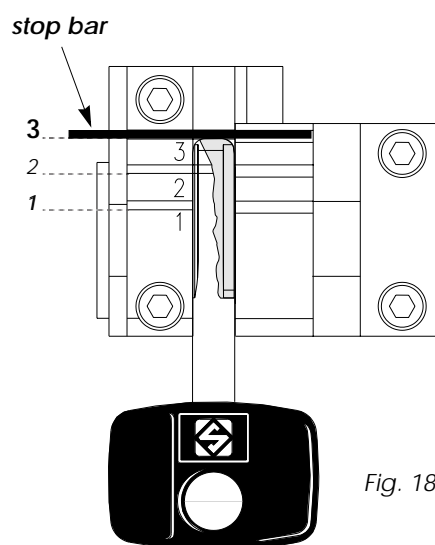

Fig. 18a

- Secure the keys with knobs (E) and (E1).
- Exclude the tracer point spring (ch.5.4).
- Activate the electromechanical setting checker and align the tools (ch.5.6).

After placing the keys in the clamps, carry out the cutting operations following the instructions relating to the type of key to be cut (ch.6.3 DIMPLE - 6.4 LASER (SIDEWINDER) - 6.5 NARROW STEMMED LASER (SIDEWINDER) - 6.6 for FICHET).

6.3 CUTTING DIMPLE KEYS

- Activate the tracer point spring system (ch.5.4).
- Turn on switch (Q) (pages 8-10).
- Grip the levers (C) and (I) and cut the key, first centering the tracer point on the hole on the original key then taking the cutting tool up to the keyblank.

6.3.1 Cutting the back

If cuts are to be made on the back, place the key in a vertical position (Fig.19a).

6.3.2 Inclined cuts

Proceed as follow for keys with inclined cuts (e.g. Kaba Gemini 15°, Vachette Radial etc.):

- loosen lever (D) to release the clamps and incline these to the angle required (see index (B3) on the graduated drum) (Fig.20).
- secure the clamps with lever (D).
- carry out the cutting.

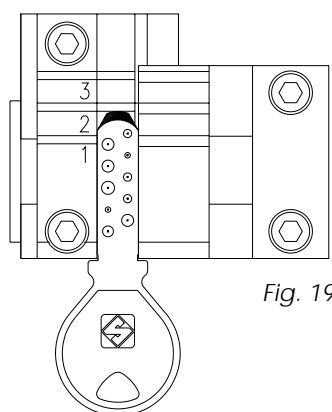

Fig. 19

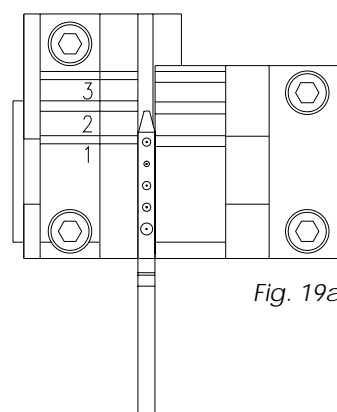

Fig. 19a

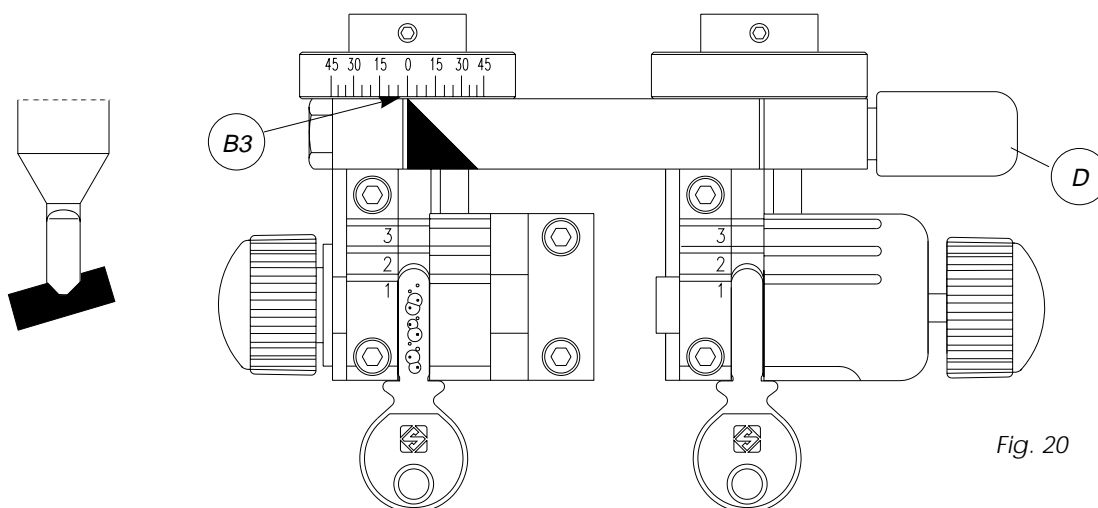

Fig. 20

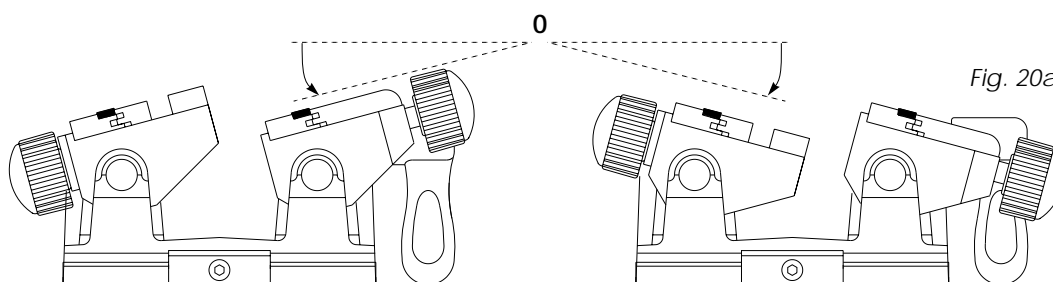

Fig. 20a

6.4 CUTTING LASER (SIDEWINDER) TYPE KEYS

- Ensure that the vertical spring system on the tracer point is locked (ch.5.4).
- Before activating the start switch (Q), lower lever (I) close to the keys and regulate the spring system for laser (sidewinder) keys (ch.5.2) with knob (O).
- Start the cutting operation by activating switch (Q).
- Lower the spindle, cut the key and stop at the beginning of the cut (Fig.21a).
 - secure the spindle at this height by turning the lever (I) clockwise (Fig.21).
 - carry out the cuts using only the left-hand lever (C).

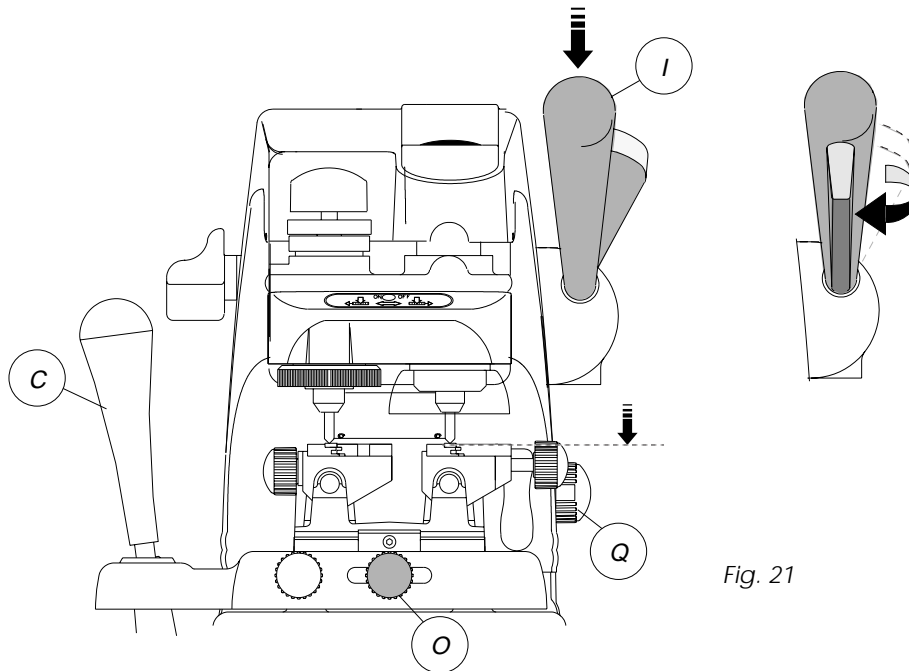

Fig. 21

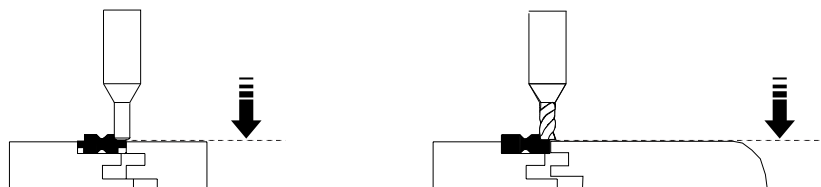
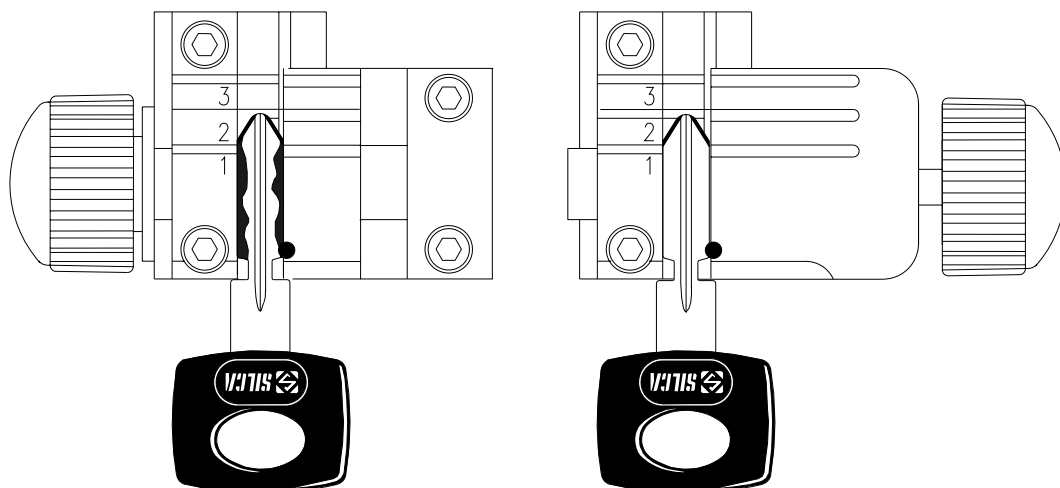

Fig. 21a



6.5 CUTTING NARROW-STEMMED LASER (SIDEWINDER) TYPE KEYS

(art.HU41P-HU55P-HU61P etc.)

The balancing clamp can also be used to cut narrow-stemmed Laser (sidewinder) keys by simply fitting the adapter provided (ch.3 Accessories provided). The procedure is as follows:

- open the clamps by loosening knobs (E) and (E1).

art. HU41P, HU64P:

- place the adapter on the left-hand jaw and align the notch with "stop 2" (Fig.23).

art. HU55P:

- place the stop bar into the groove.
- place the stop bar into the groove.
- insert the key so that it butts against the bar.
- secure the adapter and key by tightening knob (E).
- remove the bar and repeat the same operations on the right-hand jaw.

Cutting:

- ensure that the vertical tracer point spring is closed (ch.5.4).
- before activating the start switch (Q), lower lever (I) close to the keys and regulate the spring system for laser (sidewinder) keys (ch.5.2).
- Start the cutting operation by activating switch (Q).
- lower the spindle, cut the key and stop at the beginning of the cut (ch.6.4).
 - secure the spindle at this height by turning the lever (I) clockwise (Fig.21).
 - carry out the cuts using only lever (C).

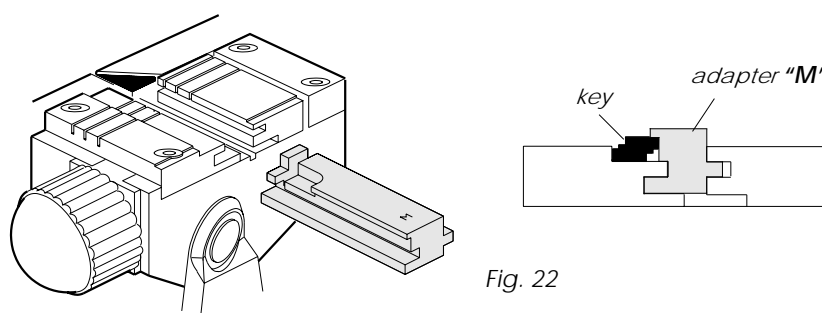

Fig. 22

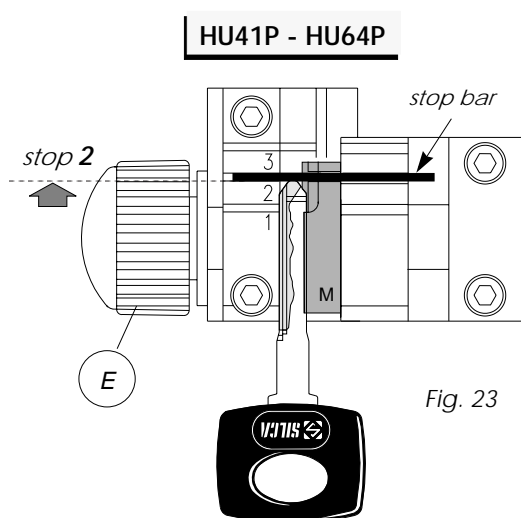

Fig. 23

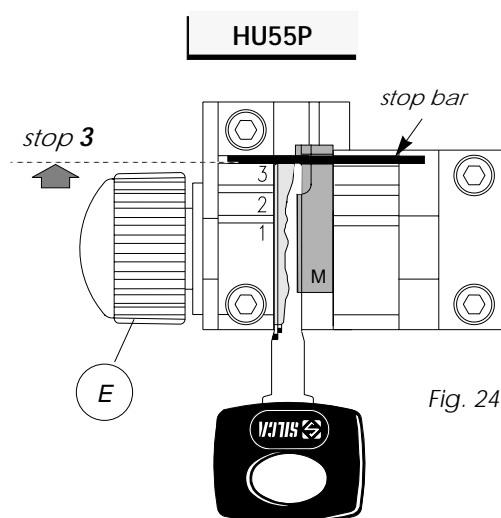

Fig. 24

6.6 CUTTING KEYS for FICHET

The balancing clamp can also be used to cut keys for FICHET (H profile) by simply fitting the adapter provided (ch.3 Accessories provided).

The procedure is as follows:

- open the clamps slightly by loosening knobs (E) and (E1).
- place the adapters all the way into the clamps (Fig.25a).
- place the keys with the stop up against the adapter (Fig.25a).
- secure the adapters and keys by tightening knobs (E) and (E1).

Cutting:

- ensure that the vertical tracer point spring is closed (ch.5.4).
- activate the Laser (sidewinder) key spring system with knob (O) (ch.5.2- central cutting).
- turn on switch (Q), lower the collet assembly and position on the beginning of the cut (ch.6.4).
 - secure the spindle at this height by turning the lever (I) clockwise (Fig.21).
 - carry out the cuts using only lever (C).

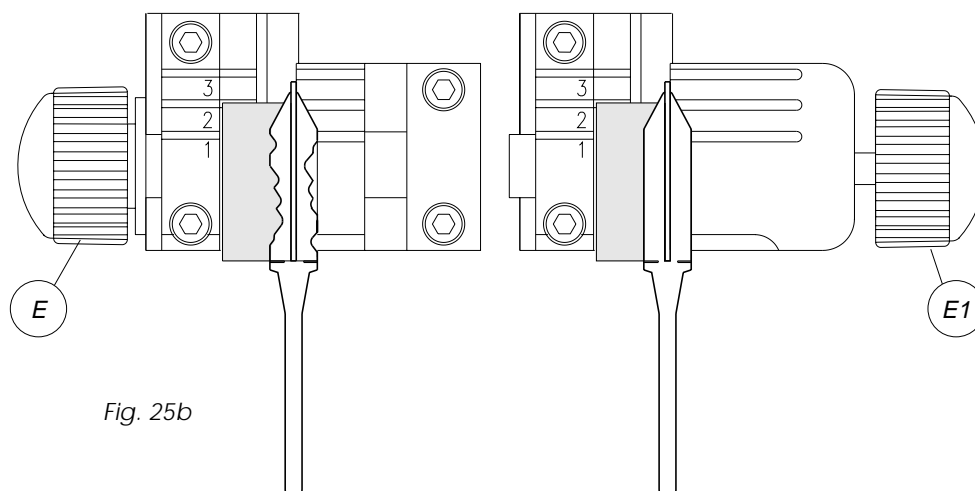
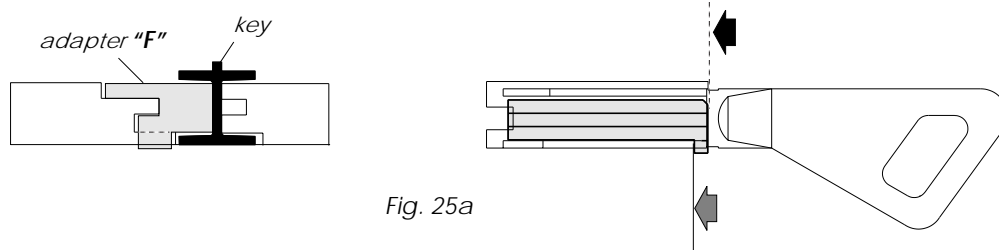
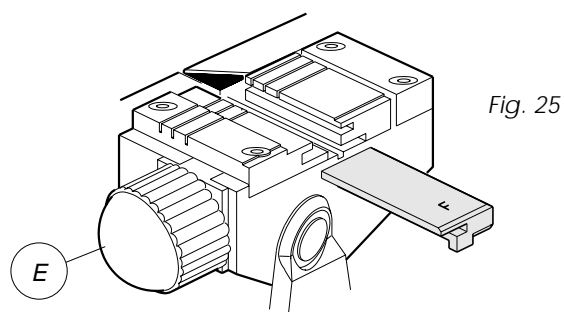

7. MAINTENANCE

- ▲ **WARNING:** for repairs or replacement of parts for maintenance, the 'CE' mark is guaranteed only if original spare parts provided by the manufacturer are used.

Although the MATRIX SX key-cutting machine does not require special maintenance, it is advisable to check and, if necessary, replace the parts subject to wear, such as: the belt (ch.7.1), the lamp (ch.7.2) and tension spring on the vertical carriage (ch.7.3). Replacement is simple and can be carried out by the operator.

CLEANING: keep the carriage and clamps free of chippings from the cutting operations by cleaning with a dry brush. ▲ **WARNING: DO NOT USE COMPRESSED AIR!**

Before starting any type of maintenance (checks or replacements), read the instructions below:

- never carry out maintenance or servicing with the machine switched on.
- always remove the mains plug.
- follow all the instructions in the manual to the letter.
- use original spare parts.

7.1 Replacing the belt and adjusting tension

If the upper part of the machine vibrates, check the tension on the belt, as described below:

1. turn off the master switch and remove the mains plug.
2. loosen the four screws (Y1) and remove the upper casing (Y) (Fig.26).
3. loosen (but do not remove) the four socket head screws (Y2) securing the motor.

4a tension:

- increase belt tension by pushing the motor towards the back of the machine.

4b replacement:

- loosen the belt by pushing the motor slightly towards the tracer point and cutting tool.
- remove the belt and replace.
- tighten the tension by pushing the motor towards the back of the machine.

5. secure the motor by tightening the four socket head screws (Y2).
6. replace the upper casing (Y) and secure with the four screws (Y1).

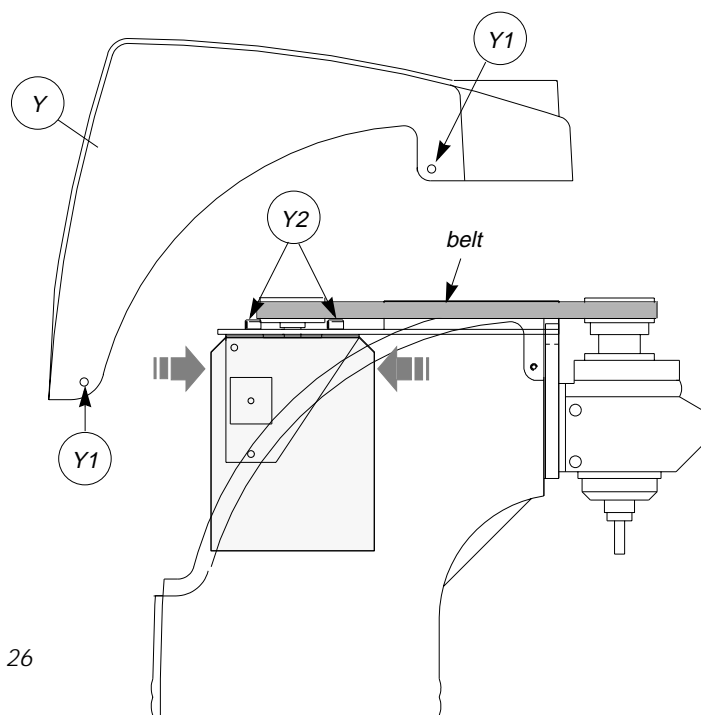

Fig. 26

7.2 Replacing the light bulb

To replace the light bulb:

1. turn off the master switch and remove the mains plug.
2. remove the four screws (J1) which secure the glass cover (Fig.27).
3. unscrew the light bulb and remove.
4. install the new light bulb and replace the glass cover with the four screws (J1).

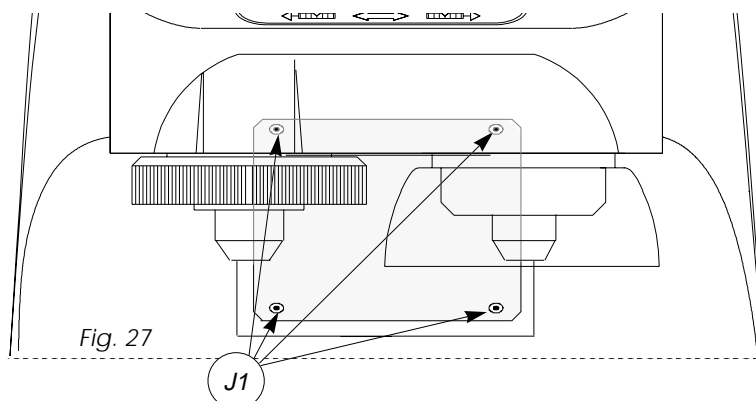

Fig. 27

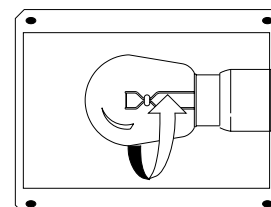

Fig. 27a

7.3 Registration/replacement of the vertical carriage tension spring

If the vertical carriage (Z axis) movements betray a lack of tension, it is advisable to register the spring or, if necessary, replace it. Proceed as follows:

1. turn off the master switch and remove the mains plug.
2. loosen the four screws (Y1) and remove the upper casing (Y) (Fig.28).
3. turn the machine round with the rear towards the operator.
- 4a **to increase spring tension:** observe the illustration ① and ② in Fig.28a.
- 4b **to reduce spring tension:** observe the illustration ① and ② in Fig.28b.
5. replace the upper casing (Y) and secure with the four screws (Y1).

To replace the spring: follow the instructions in 1. 2. 3. above, replace the spring and regulate tension.

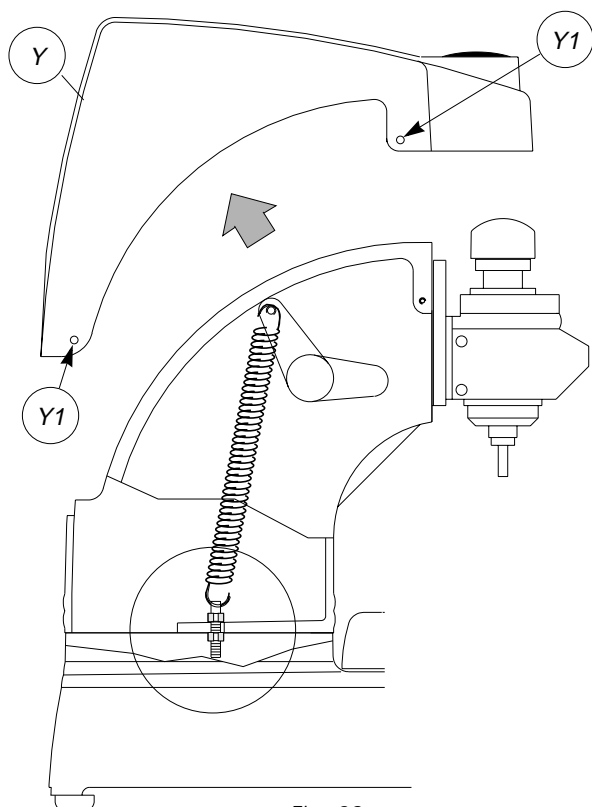

Fig. 28

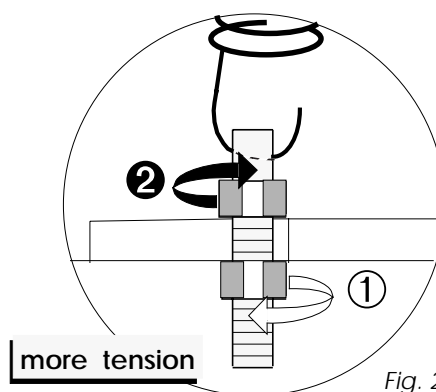

Fig. 28a

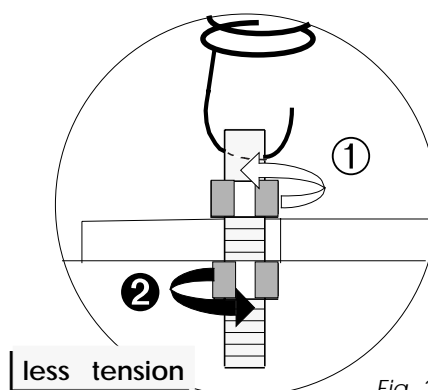

Fig. 28b

7.4 Checking and replacing the fuses

The fuses should always be checked with a continuity measuring instrument (tester, ohmmeter, multimeter etc.) as a visible check may not reveal an electrical fault. Fuses must always be replaced with others of the same type (rapid or delayed) and with the same Amps, as shown in the manual.

The MATRIX SX key-cutting machine has two fuses:

2 Amps rapid for machines with 230 Volts

3,15 Amps rapid for machines with 115 Volts

placed in the inlet socket next to the master switch (P) (Fig.29), to protect the key-cutting machine from sudden changes in voltage or short circuits.

It is advisable to check the fuses if the machine is not activated by turning on the master switch. Proceed as follows:

1. turn off the master switch (P) and remove the mains plug.
2. remove the fuse board with the aid of a screwdriver (Fig.29).

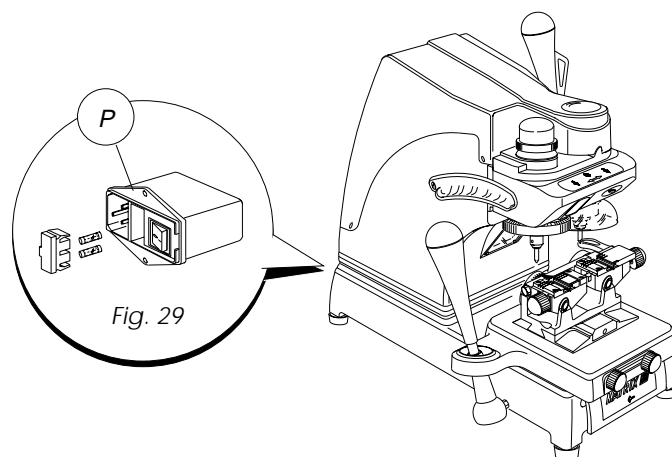

7.5 Replacing the electronic board for the keypad

If the keypad (K) is not working properly, replace the internal electronic board.

Proceed as follows:

1. turn off the master switch and remove the mains plug.
2. remove the four screws which secure the template (Z4) and remove.
3. disconnect the connector (Z3).
4. remove the adhesive label (K) and unscrew the two screws securing the board.
5. replace the board, secure with the two screws and reconnect the connector (Z3).
6. re-position the template on the machine, secure with the four screws and attach the adhesive label/display (K).

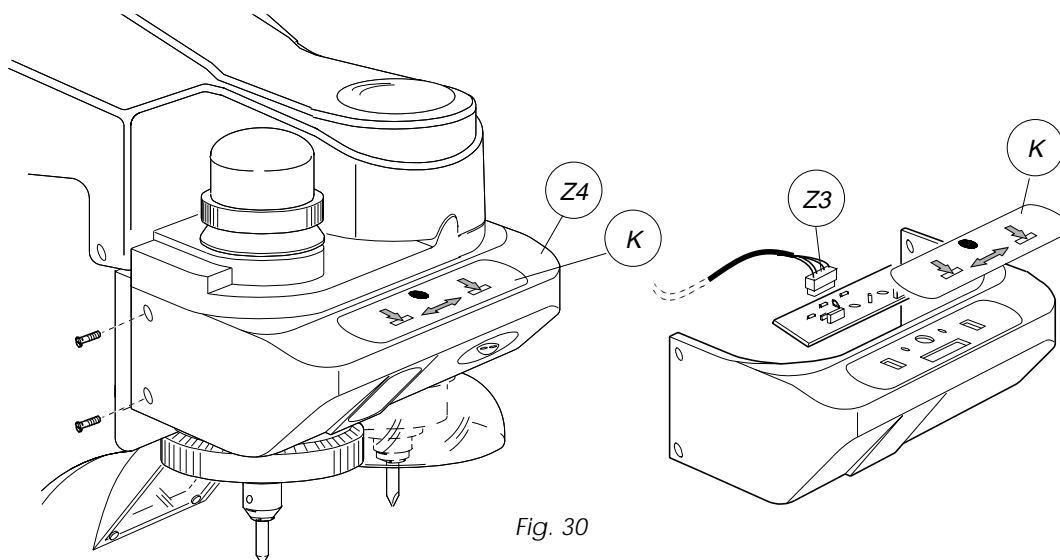

Fig. 30

8. WASTE DISPOSAL

EU regulation establish special arrangements for the disposal of waste (*).

Waste deriving from cutting operations

Although residue coming from the key-cutting operations is classified as special waste, it is included in solid urban waste (SUW) as metal wool.

Such waste is sorted according to its classification under current Italian and EU law and consigned to the proper disposal units.

Cases where waste can be considered contaminated or containing toxic/harmful substance sufficient to transform it from SUW to toxix/harmful waste, are listed in the enclosures to current Italian and EU waste disposal regulations.

Cutting machine

The MATRIX SX key-cutting machine is designed for many years of operations and is also re-usable. Re-cycling is a recommended ecological practice.

Packing

The MATRIX SX is consigned in a cardboard packing box which can be re-used if undamaged. When it is to be thrown away it is cassified as solid urban waste and should be placed in the special paper collecting bins.

The protective shell containing the machine is in polymer, classifield as SUW, and can therefore be placed in an ordinary waste bin.

- (*) "Waste" is any substance or object deriving from human activity or natural cycles, thrown away or to be thrown away.

9. ASSISTANCE

Silca provides full assistance to purchasers of the MATRIX SX key-cutting machine.

To ensure complete safety for the operator, an job not specified in this manual should be carried out by the manufacturer or in the special Service Centres recommended by Silca.

On the back cover of the this manual is a list of the manufacturer's addresses; listed below are the addresses of specialised Service Centres.

9.1 How to request service

The guarantee attached to MATRIX SX key-cutting machine ensures free repairs or replacements of faulty parts within six months of purchase. All other service calls must be arranged by the customer with Silca or with Silca Service Centre.



SILCA S.p.A.
Via Podgora, 20 (Z.I.) 31029 VITTORIO VENETO (TV)
Tel. 0438 9136 Fax 0438 913800
www.silca.it

Member of the Kaba Group

