

MATRIX

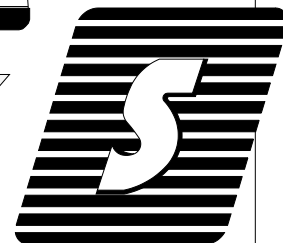

Operating manual

D411773XA

vers. 1.1



(c) 1994 SILCA S.p.A. - Vittorio Veneto

This manual has been drawn up by SILCA S.p.A.

All rights reserved. No part of this publication may be reproduced or used in any form or by any means (photocopying, microfilm or other) without the permission of SILCA S.p.A.

First published in July 1994

Printed in Vittorio Veneto
by SILCA S.p.A.
via Podgora, 20 (Z.I.)
31029 VITTORIO VENETO (TV) - Italy

INDEX

USE OF TOOLS PROVIDED	5
GUIDE TO THE MANUAL	7
GENERAL INSTRUCTIONS	8
1 TRANSPORT	9
1.1 Packing	9
1.2 Transport	10
1.3 Opening the packing	10
1.4 Handling the machine	10
2 MACHINE DESCRIPTION	11
2.1 Working parts	13
2.2 Technical data	14
2.3 Graphics	14
2.4 Electrical circuit	15
3 ACCESSORIES PROVIDED	17
4 MACHINE INSTALLATION and PREPARATION	18
4.1 Checking for damage	18
4.2 Atmospheric conditions	18
4.3 Positioning	18
4.4 Description of work station	18
5 MACHINE REGULATION and REGISTRATION	19
5.1 Fitting and regulating the tools	19
5.2 Setting	20
5.3 Spring system for LASER (sidewinder) type keys	21
5.4 Clamps	23
5.5 Micrometric ring nut	23
5.6 Hand rest	23
6 CUTTING OPERATIONS	24
6.1 Fitting the keys	24
6.2 Key stop	24
6.3 Cutting dimple keys	25
6.3.1 Cutting the back	25
6.4 Cutting laser (sidewinder) type keys	26
6.5 Cutting narrow-stemmed laser (sidewinder) type keys	27
6.6 Cutting keys for Fichet	28
7 MAINTENANCE	29
7.1 Replacing the belt and adjusting tension	29
7.2 Replacing the light bulb	30
7.3 Registration/replacement of the vertical carriage tension spring	30
7.4 Checking and replacing the fuses	31
7.5 Replacing the electronic board for the keypad	31
8 WASTE DISPOSAL	32
9 ASSISTANCE	33
9.1 How to request service	33

USE OF TOOLS PROVIDED

MAIN BRAND MARCA MARQUE MARQUE MARCA	SILCA KEYBLANK ARTICOLO SILCA SILCA-ARTIKEL ARTICLE SILCA ARTÍCULO SILCA	MACHINE MACCHINA MASCHINE MACHINE MÁQUINA	TRACER POINT TASTATORE TASTER PALPEUR PALPADOR		CUTTING TOOL FRESINO FRÄSER FRAISE FRESA	
ABUS (D)	AB40	SLX - SX - S	T1	D401070RA	F1	D701071ZB
AZBE (E) (CAVERS)	AZ6-AZ7	SLX - SX - S	T42	D408799RA	F42	D708800ZB
CISA (I)	CS48	SLX - SX - S	T1	D401070RA	F1	D701071ZB
DOM (D)	DM21 - DM55 - DM58	SLX - SX - S	T1	D401070RA	F1	D701071ZB
ELCA (D) TESA (E)	EC5	SLX - SX - S	T1	D401070RA	F1	D701071ZB
FICHET (F)	FT500	SLX - SX - S	T22	D405487RA	F22	D705488ZB
FTH (F) (YALTRES)	FH12	SLX - SX - S	T5	D401078RA	F5	D701079ZB
GE-GE (A)	GE57	SLX - SX - S	T1	D401070RA	F1	D701071ZB
GIOBERT (I) SAFE (I)	GT2P - GT2 - GT2BP (LANCIA) GT9AP - GT2AP (ALFA ROMEO) GT2CP	SLX - SX - S	T1	D401070RA	F1	D701071ZB
HONDA (J)	HON60AP (LEGEND)	SLX - SX - S	T44	D409147RA	F44	D709148ZB
HUF (D)	HU59 - HU58AP (BMW)	SLX - SX - S	T22	D405487RA	F22	D705488ZB
HUF (D)	HU44AP - HU41P HU61AP - HU55P HU40P - HU39P (MERCEDES)	SLX - SX - S	T22	D405487RA	F22	D705488ZB
HUF (D)	HU57RP - HU56RP (VOLVO)	SLX - SX - S	T22	D405487RA	F22	D705488ZB
HUF (D) YMOS (D)	HU43P - YM27P (OPEL-VAUXHALL)	SLX - SX - S	T22	D405487RA	F22	D705488ZB
KABA (CH)	KA1 - KA2 - KA3 KA4 - KA5 - KA6	SLX - SX - S	T1	D401070RA	F1	D701071ZB
KABA (CH)	KA2 - KA9	SLX - SX	T43	D408987RA	F43	D708988ZB
KESO (CH)	KE3 (82°)	SLX - SX - S	T26	D405654RA	F26	D705655ZB
MCM (E)	MC9	SLX - SX - S	T37	D406653RA	F37	D706654ZB
MCM (E)	MC9	SLX - SX - S	T38	D406656RA	F38	D706657ZB

MAIN BRAND MARCA MARKE MARQUE MARCA	SILCA KEYBLANK ARTICOLO SILCA SILCA-ARTIKEL ARTICLE SILCA ARTÍCULO SILCA	MACHINE MACCHINA MASCHINE MACHINE MÁQUINA	TRACER POINT TASTATORE TASTER PALPEUR PALPADOR		CUTTING TOOL FRESINO FRÄSER FRAISE FRESA	
MCM (E)	MC9	SLX - SX - S	T39	D406658RA	F39	D706659ZB
MCM (E)	MC10R + COPPIA ADATTATORI D711137ZB	SLX - SX - S	T50	D411145RA	F50	D711144ZB
MUL-T-LOCK (IL)	MTK1-MTK2P	SLX - SX - S SLX - SX - S	T12A T12B	D501090ZM D401092RA	F12A F12B	D701091ZB D701093ZB
NEIMAN (D)	NE67AP - NE66P - NE66 (VOLVO)	SLX - SX - S	T22	D405487RA	F22	D705488ZB
NISSAN (J)	NSN10AP - NSN10 - NSN9P (INFINITI)	SLX - SX - S	T22	D405487RA	F22	D705488ZB
SPIDER (IL)	SPR1 - SPR2	SLX - SX - S	T1	D401070RA	F1	D701071ZB
STS (E)	STS5-STS6	SLX - SX - S	T5	D401078RA	F5	D701079ZB
TESA (E)	TE4R	SLX - SX - S	T1	D401070RA	F1	D701071ZB
TESA (E)	TE7	SLX - SX	T5	D401078RA	F5	D701079ZB
TOYOTA (J)	TOY40 - TOY40AP - TOY40P (LEXUS)	SLX - SX - S	T22	D405487RA	F22	D705488ZB
YARD YARDENI (IL)	YD3R	SLX - SX - S	T1	D401070RA	F1	D701071ZB
YMOS (D)	YM30P (SAAB)	SLX - SX - S	T22	D405487RA	F22	D705488ZB
ZADI (I)	ZD20	SLX - SX - S	T5	D401078RA	F5	D701079ZB

GUIDE TO THE MANUAL

This manual has been produced to serve as a guide for users of the MATRIX S key-cutting machine. Read it carefully; it is essential if you wish to operate your machine safely and efficiently.

Consultation

The contents of the manual are divided into sections relating to:

- Transport and handling	Chapter	1
- Checking the safety of the machine	Chapter	4
- Proper use of the machine.....	Chapters	5-6
- Maintenance	Chapter	7

Technical terms

Common technical terms are used in this manual; fig. 1 shows the names of the different parts of the keys most commonly copied with the MATRIX S.

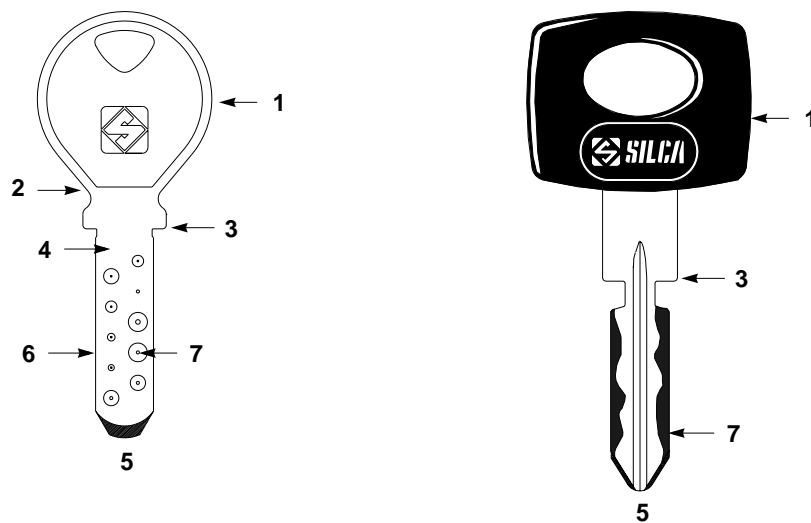

DIMPLE KEYS

Keys with holes of different dimensions, depths, positions and shapes.

LASER (SIDEWINDER) TYPE KEYS

LASER is the name given to the special sidewinder milled keys.

Fig. 1

- 1) Head
- 2) Rim
- 3) Stop
- 4) Stem
- 5) Tip
- 6) Back
- 7) Cuts

GENERAL INSTRUCTIONS

The MATRIX S key-cutting machine has been designed according to the specifications of the Machine Directives. Right from the design stage risks for the operator have been eliminated in all areas: transport, key-cutting, regulation and maintenance.

Other risks have been eliminated by the use of protective devices for the operator.

The protective devices used are designed not to provoke further risks and, above all, they cannot be ignored unless deliberately cut out. They do not hinder visibility of the work area.

A special adhesive label is attached to the machine warning the operator to use goggles during the cutting operations, and this is strongly recommended in this manual.

The material used in the manufacture of this machine and the components employed during use of the machine are not dangerous and their use complies with standards.

Use

The MATRIX S must be installed and used in the way laid down by the manufacturer.

If the key-cutting machine is used differently or for purposes different from those described in this manual, the customer will forego any rights he may have over Silca S.p.A. Furthermore, unforeseen danger to the operator or any third parties may arise from incorrect use of the machine.

Negligence in the use of the machine or failure on the part of the operator to observe the instructions given in this manual are not covered by the guarantee and the manufacturer declines all responsibility in such cases.

It is therefore indispensable to read the operating manual carefully in order to make the best use of the MATRIX S and benefit from its potential.

Further risks

There are no further risks arising from the use of the MATRIX S key-cutting machine.

Protection and safety precautions for the operator

The MATRIX S key-cutting machine is built entirely to standards. The operations for which it has been designed are easily carried out at no risk to the operator.

The adoption of general safety precautions (wearing protective goggles) and observation of the instructions provided by the manufacturer in this manual eliminate all human error, unless deliberate.

The MATRIX S key-cutting machine is designed with features which make it completely safe in all its parts.

- **Power supply**

The machine is supplied with electricity by means of an earthed plug and differential switch.

- **Start-up**

The machine is started up by means of the master switch on the back.

- **Operations**

The motor start switch activates the cutting tool.

- **Illumination**

The work area is illuminated by a lamp which operates when the machine is switched on with the master switch.

- **Maintenance**

The operations to regulate, service, repair and clean the machine have been devised in the simplest possible way. There is no danger of removable parts being replaced wrongly or unsafely.

- **Machine identification**

The MATRIX S key-cutting machine is provided with an identification label which shows the serial number (fig. 2).

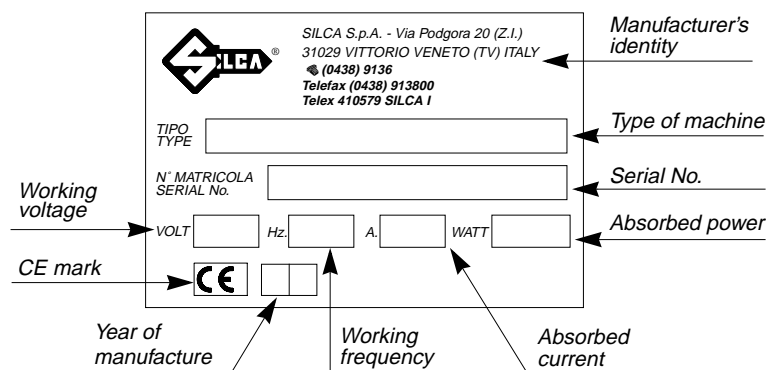

Fig. 2

1 TRANSPORT

The MATRIX S key-cutting machine is easily transported and is not dangerous to handle. The packed machine can be carried by one person.

1.1 Packing

The packing used for the MATRIX S guarantees that the machine will travel safely without danger of damage to it or its components.

The packing comprises two shells, (a) lower and (b) upper and 2 supports (c) in expanded plastic in the machine is wrapped (fig. 3).

A strong outer cardboard box, the measurements of which can be seen in fig. 4, and the plastic wrapping protect the machine even over a long period of storage.

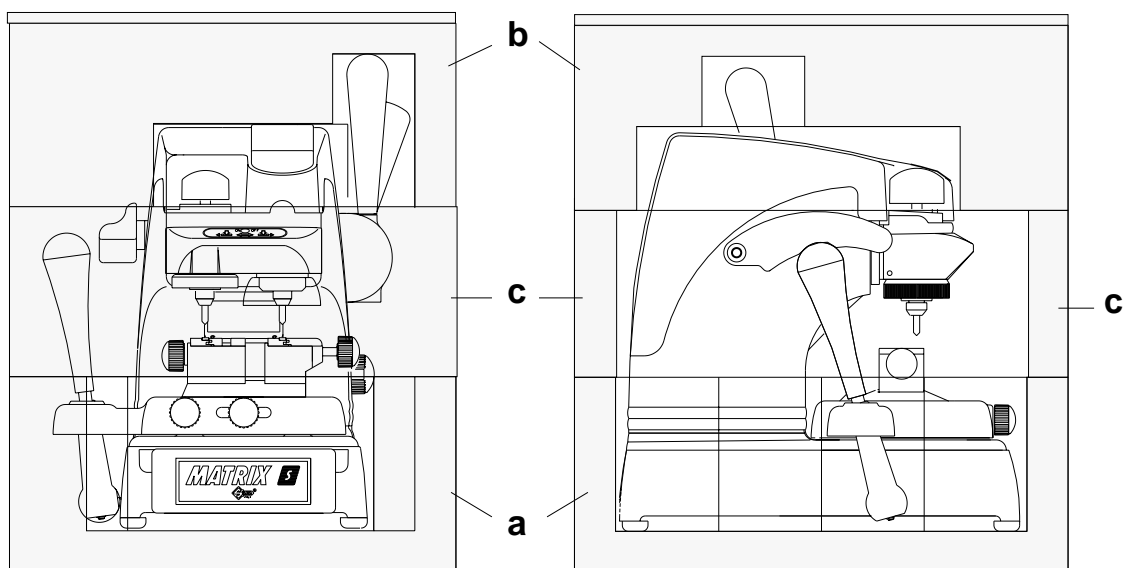

Fig. 3

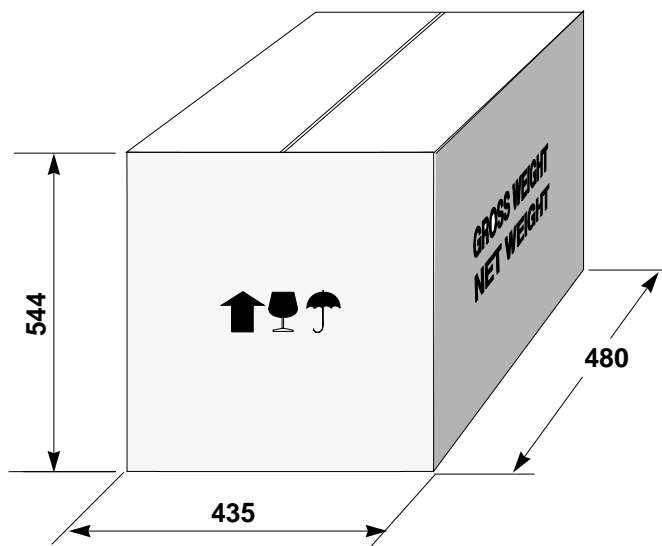

Fig. 4

1.2 Transport

The symbols on the outside of the packing box show the ideal conditions for transport. Use of the packing box whenever the machine is transported will avoid knocks or bumps which could cause damage.

1.3 Opening the packing

To remove the machine from the packing box:

- 1) cut the straps with scissors and remove.
- 2) prise off the staples.
- 3) open the box without damaging it as it may be used again (removals, despatch to the manufacturers for repairs or servicing).
- 4) check the contents of the box, which should comprise:
 - 1 MATRIX S key-cutting machine packed in a protective shell.
 - 1 set of documents including: operating manual, spare parts list and guarantee.
 - 1 connecting wire.
- 5) remove the key-cutting machine from the protective shell.

1.4 Handling the machine

When the MATRIX S has been unpacked, place it directly on its workbench.

This operation can be carried out by one person, firmly holding the base, and no other part, to lift and carry the machine.

2 MACHINE DESCRIPTION

The MATRIX S is an excellent quality, high precision key-cutting machine. It features great versatility in cutting keys of different types without the need to replace the clamp or apply fixed adapters. MATRIX S cuts the following types of keys:

- **dimple keys (with flat cuts)**
- **Laser (sidewinder) type keys**
- **keys for Fichet**

dimple keys

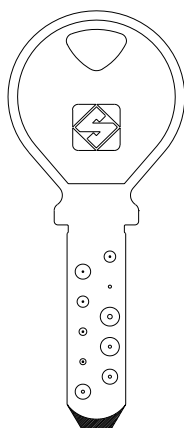

Laser (sidewinder) type keys



*keys for Fichet**

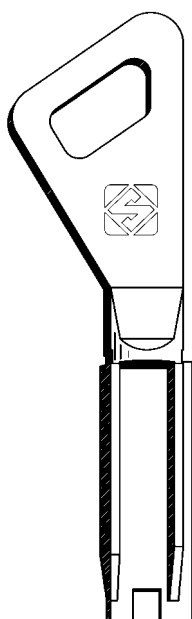

*Laser narrow-stemmed (sidewinder) type keys**

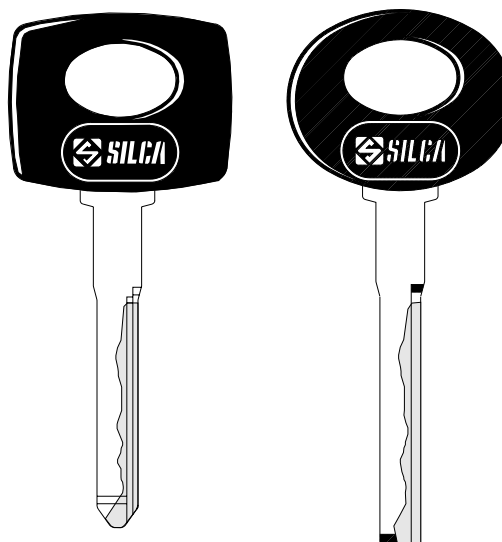

(*) ADAPTERS PROVIDED

High precision work is guaranteed by the combination of the functional features on the MATRIX S and all its components, such as:

- **Safety device**

The device is connected to a power plug with a differential switch. It activates the key-cutting machine when the illuminated ON button (Z) is pressed and cuts out when the OFF button (V) is pressed.

- **Movements**

The three axes move on ball guides which provide smooth running and easy sliding without play.

- **Spring system for laser (sidewinder) keys**

The machine is provided with a system which controls the run of the cross axis so that the operator can easily trace the outline of the cuts along the key shaft.

- **Electromechanical setting**

A precision electromechanical system ensures centesimal regulation of settings, made easier and quicker by the warning lights on the machine key pad.

- **Protective shield**

A special transparent plastic shield prevents chippings from flying into the air.

- **Lamp**

Placed directly on the machine, it illuminates the work area.

- **Centesimal micrometric ring nut**

Ensures perfect depth alignment of the tools and makes it possible to adjust for defects on worn keys with minute, controllable depth variations ($\pm 0,02$ mm).

- **Levers and knobs**

Each lever and knob has been designed with dimensions, materials and positions which render grip and movement extremely simple.

Materials and finish have been chosen according to the use of each part, especially:

- **lever (I) for vertical carriage (Z axis) (fig. 5)**

ergonomic and provided with a locking mechanism which allows registration of the height of the cutter assembly from the cutting surface, adapting this to the key (especially useful when cutting Laser (sidewinder) keys) without a need for the operator.

- **lever (C) X-Y axes (fig. 5)**

the lever which guides movement along the X-Y axes is ergonomic and makes precise, sensitive movements due to a special joint with ball articulation and slide on ball guides.

- **hand rest (R) (fig. 5)**

the movement of the cutting tool along the cuts for both Laser (sidewinder) and dimple keys is facilitated by an adjustable hand rest which guarantees smooth, synchronised carriage movements during the cutting operations.

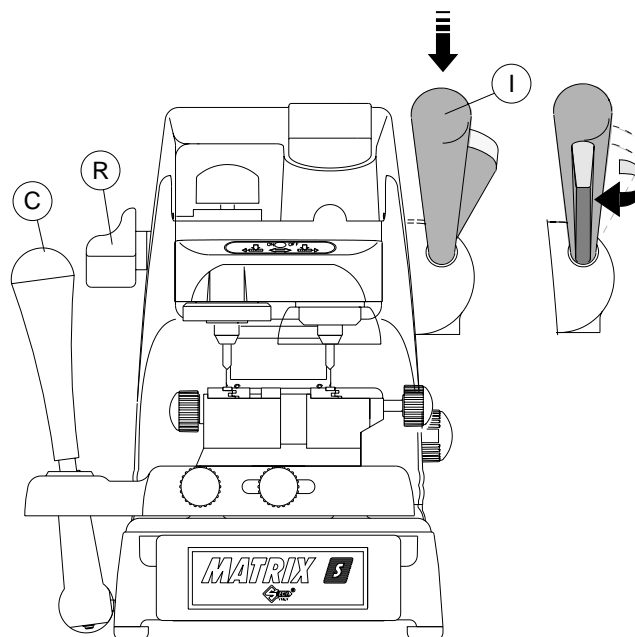

Fig. 5

2.1 Working parts

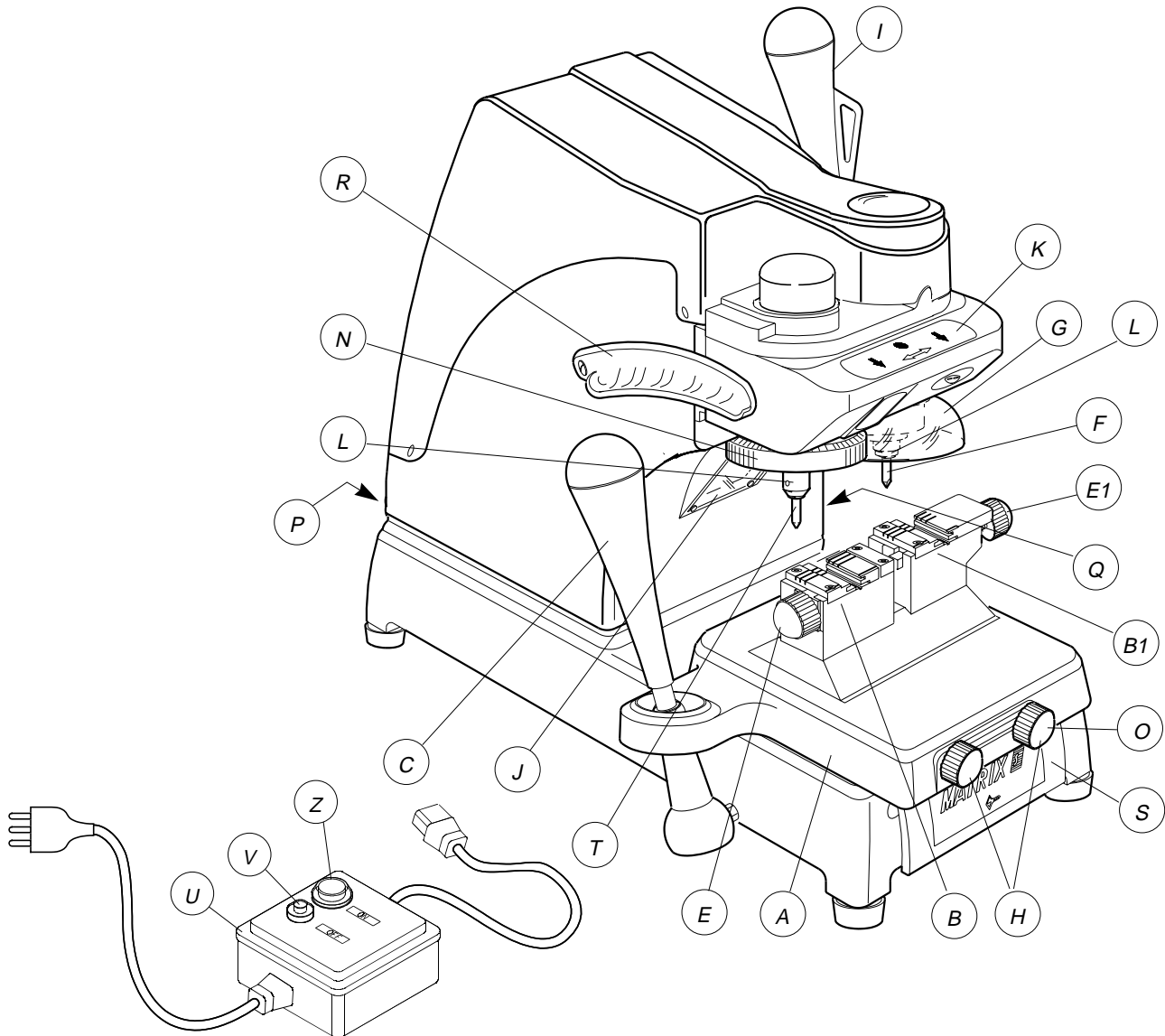

Fig. 6

- A - clamp carriage (X-Y axes)
- B - left-hand jaw
- B1- right-hand jaw
- C - clamp carriage lever (X-Y axes)
- E - left-hand jaw knob
- E1- right-hand jaw knob
- F - cutting tool
- G - protective shield
- H - Clamp carriage locking knobs
- I - vertical carriage lever (Z axis)
- J - lamp
- K - setting unit keypad
- L - sleeve (cutting tool and tracer point holder)
- N - micrometric ring nut for regulating tracer point
- O - regulating knob for Laser (sidewinder) key spring system
- P - master switch
- Q - motor start switch
- R - hand rest (left hand)
- S - tool drawer
- T - tracer point
- U - Safety device
- V - OFF button
- Z - ON button

2.2 Technical data

MOTOR: One-speed single phase: 230V-50Hz; 230V-60Hz (other voltages on request)

CUTTING TOOL: Super rapid steel

CUTTER SPEED: 6000 rpm

MOVEMENTS: on three axes by ball guides

CLAMP: fixed with sliding jaws and interchangeable plates

RUNS: X axis: 40 mm; Y axis: 50 mm; Z axis: 20 mm

ILLUMINATION: 25W incandescent lamp

DIMENSIONS: width: 350 mm depth: 400 mm height: 455 mm

WEIGHT: 20 Kg

SOUND PRESSURE: $L_p (A) = 76,3 \text{ dB (A)}$

2.3 Graphics

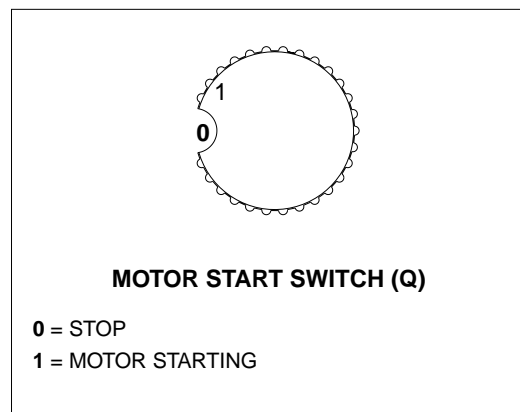
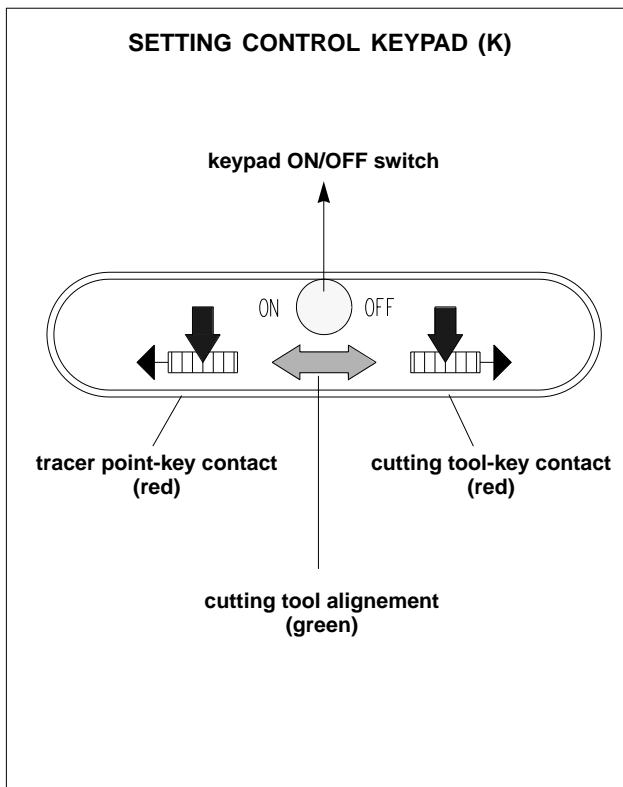

2.4 Electrical circuit

The main parts of the electrical and electronic circuit on the MATRIX S are listed below:

- 1) Mains inlet: houses the master switch, the suppressor which protects the machine from interference in the mains supply and the two rapid fuses which protect the two phases from short circuits.
- 2) Central terminal board: for the connection of the electrical and electronic parts.
- 3) Transformer: supplies power to the electronic board and led warning lights on the setting keypad.
- 4) Motor switch: activates the motor.
- 5) Motor: single phase brush motor.
- 6) Lamp: illuminates the work area.
- 7) Electronic board for setting control: the board is powered at low voltage from the transformer (3) and is connected electrically to the clamps (8), tracer point (9) and cutting tool (10). It signals the correct setting by illuminating the relevant leds.

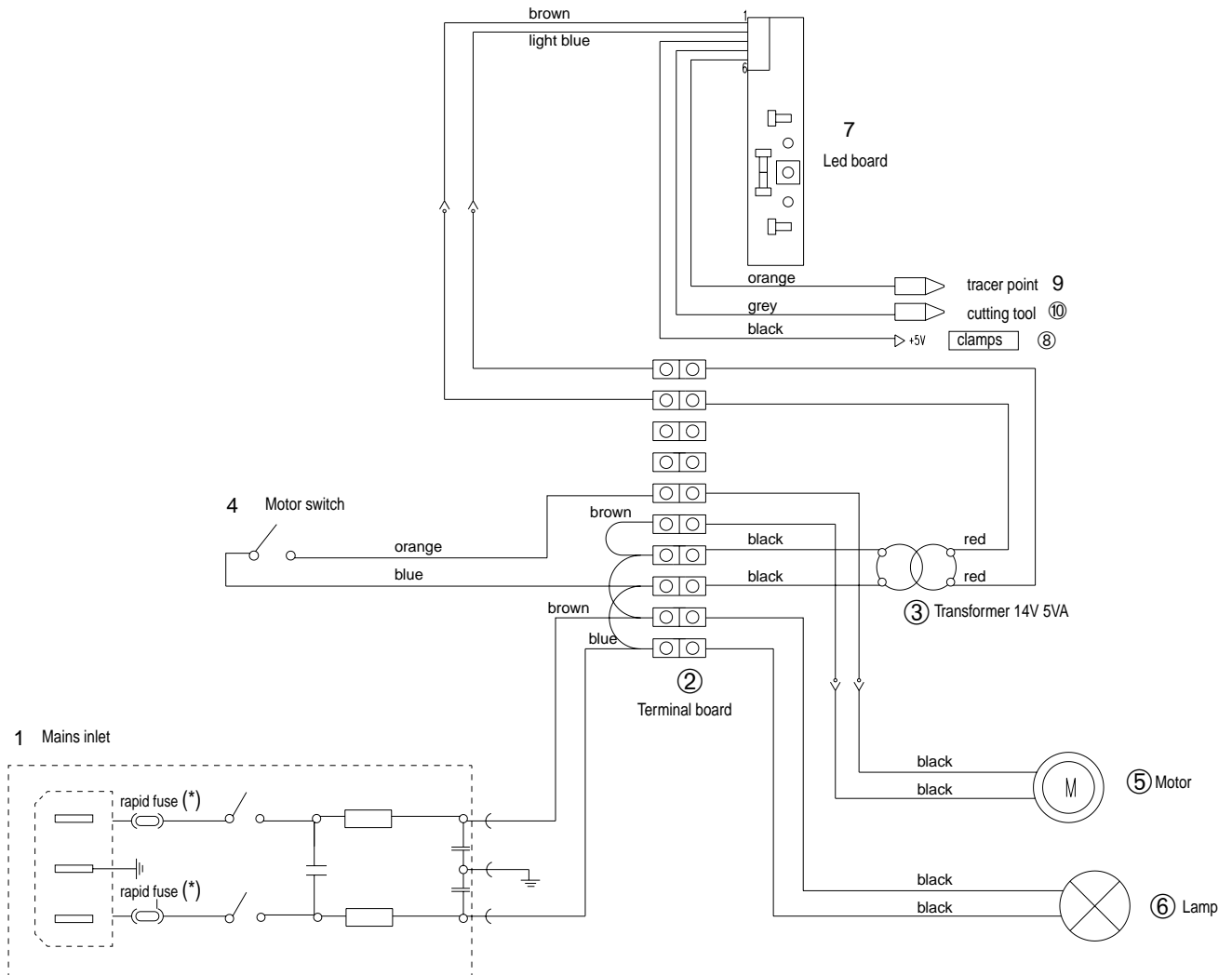

(*) 3,15 Amps for 115V
2 Amps for 230V

Safety device

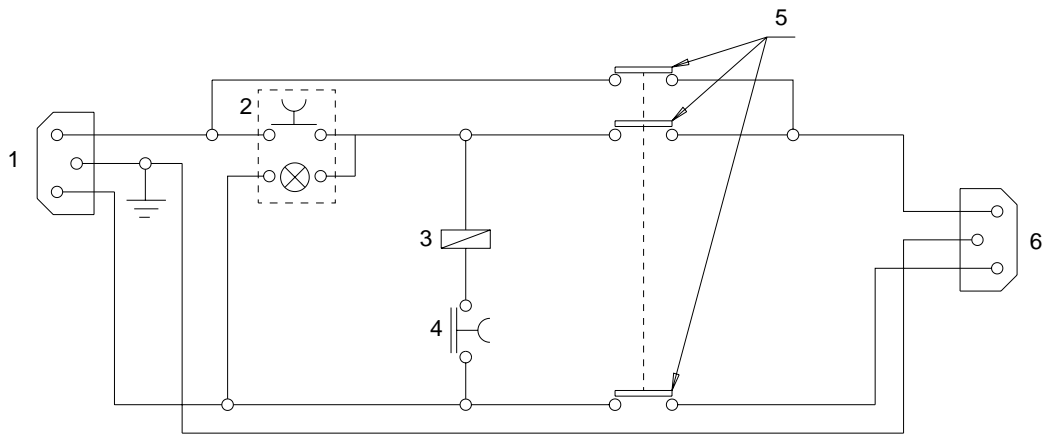

- 1) Safety device inlet
- 2) Illuminated ON button
- 3) 3 contacts relay, 220V a.c.
- 4) OFF button
- 5) Relay contacts
- 6) Safety device plug

3 ACCESSORIES PROVIDED

A set of accessories is supplied for use with the machine or for servicing (tools, Allen keys and adapters).

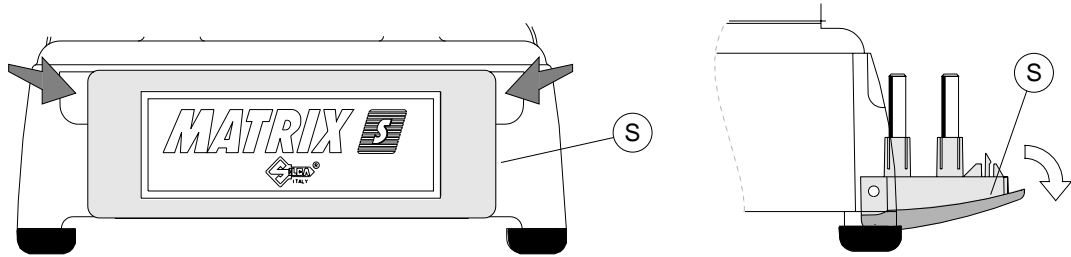
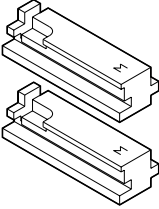

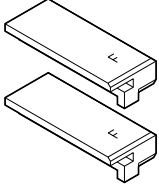

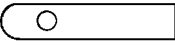

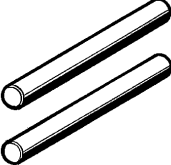

Fig. 7

The accessories are housed in a special drawer in the base of the machine (S) (fig. 7) and include:

 <p>code D410533BA ADAPTER for narrow stemmed Laser keys 2 pcs</p>	 <p>code D400222ZZ 2.5 mm ALLEN KEY</p>
 <p>code D410534BA ADAPTER for keys for FICHET 2 pcs</p>	 <p>code D400224ZZ 4 mm ALLEN KEY</p>
 <p>code D705488ZB F22 CUTTING TOOL for Laser (sidewinder) keys</p>	 <p>code D402302BA STEEL TIP STOP BAR 1 pc</p>
 <p>code D405487RA T22 TRACER POINT for Laser (sidewinder) keys</p>	 <p>FUSE (2 pcs) code D310757ZZ 2 Amps rapid for 230V code D309226ZZ 3,15 Amps rapid for 115V</p>
 <p>code D402903RA TESTING PIN 2 pcs</p>	

4 MACHINE INSTALLATION AND PREPARATION

The key-cutting machine can be installed by the purchaser and does not require any special skills. The machine is supplied ready for use and does not need to be set up, except when changing to different tools. However, some checks and preparation for use need to be carried out by the operator.

4.1 Checking for damage

The MATRIX S key-cutting machine is solid and compact and will not normally damage if transport, unpacking and installation have all been carried out according to instructions. Notwithstanding, it is always advisable to check that the machine has not suffered any damage.

4.2 Atmospheric conditions

To ensure that the best use is made of the MATRIX S key-cutting machine, certain parameters must be borne in mind:

- damp, badly ventilated sites should be avoided;
- the ideal conditions for the machine are:
 - temperature: from 0 to 40°C
 - relative humidity: approx. 60%

4.3 Positioning

Place the key-cutting machine on a horizontal surface, solid enough to take the weight. The workbench should be approx. 100-120 cm high to give easy access to the working parts of the machine.

Leave enough space around the machine (20-30 cm) to ensure good ventilation and room for manoeuvre.

ATTENTION: ensure that the key-cutting machine voltage is suitable for the mains supply available, which must be earthed and provided with a differential switch.

4.4 Description of work station

Note: the letters in brackets refer to fig.6, page 13.

The key-cutting machine needs only one operator, who has the following controls at his/her disposal:

- master switch (P) placed on the back of the machine.
- motor start switch (Q) (on the right-hand side of the machine).
- tool setting keypad (K).
- levers:
 - lever (C) to move the clamp carriage
 - lever (I) to move the vertical carriage.

5 MACHINE REGULATION AND REGISTRATION

Before carrying out cutting operations is necessary proceed with regulation about:

- fitting the tools and setting;
- the cross spring for Laser (sidewinder) keys.

5.1 Fitting and regulating the tools

ATTENTION: make sure that the motor start switch (Q) is in "0" position (STOP).

Switch on the machine with the master switch.

Select the tools for the key to be cut and proceed as follows:

- 1) place the tracer point all the way into the left-hand sleeve and secure by tightening the grub screw (M) (fig. 8).
- 2) place the cutting tool all the way into the right-hand sleeve and secure by tightening the grub screw (M1).

Releasing the tools

Unscrew the grub screw (M) and (M1) to remove the tracer point and cutting tool from the sleeves.

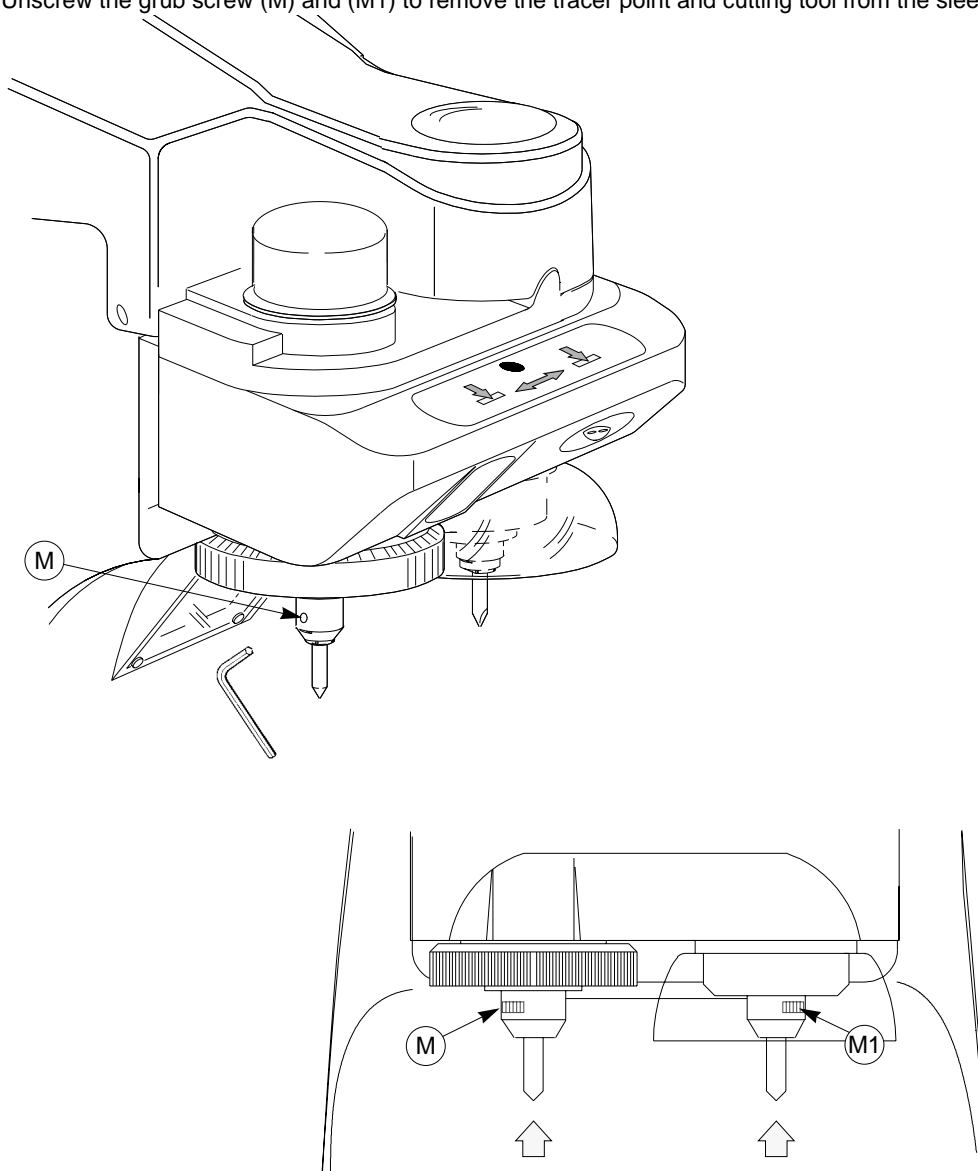

Fig. 8

5.2 Setting

- 1) Place the keys into the clamps (the original in the left-hand jaw and the keyblank in the right-hand jaw) and turn on the machine with the master switch.
- 2) Set up the tools (ch. 5.1).
- 3) Activate the electromechanical setting checker by striking the ON/OFF switch on the keypad (K) and start setting operations:
 - a) lower the vertical carriage and rest the tools lightly on an uncut part of the keys.
 - b) when the tools come into contact with the keys, one of the three warning lights will illuminate: (K1 - green), (K2 - red) or (K3 - red) (fig. 9).

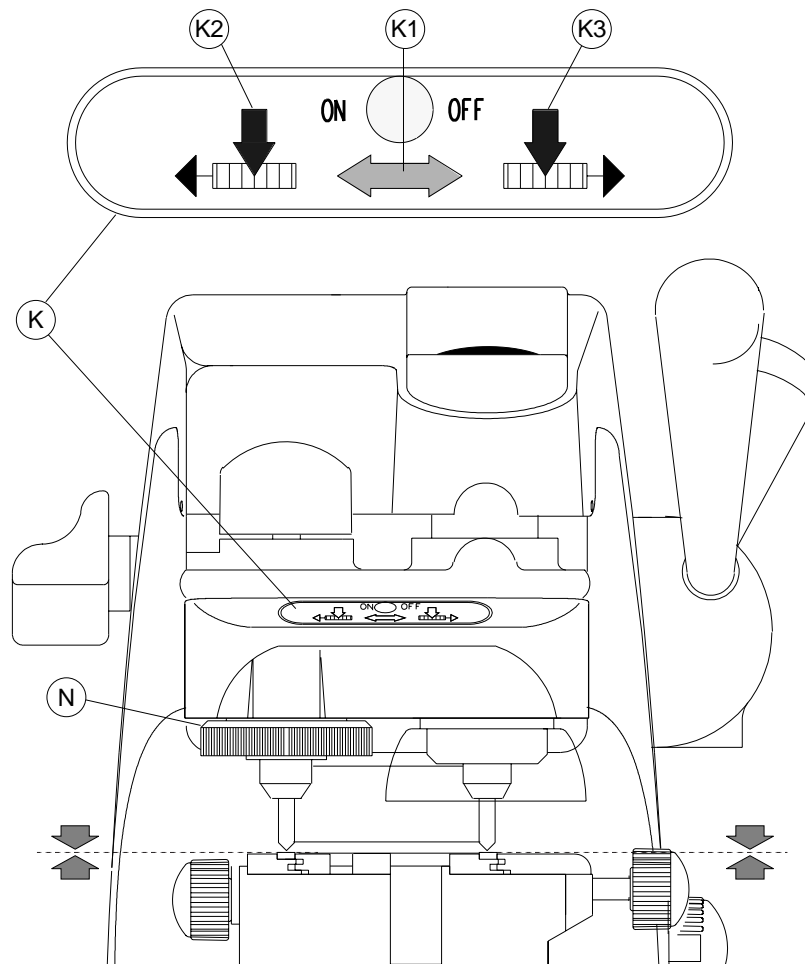

Fig. 9

Illumination of the green arrow (K1):

- the tools are aligned and do not need regulating.

Illumination of the red arrow (K2):

- only the tracer point is in contact with the key; turn the micrometric ring nut (N) clockwise (as shown) until the green arrow (K1) illuminates to show that the tools are aligned.

Illumination of the red arrow (K3):

- only the cutting tool is in contact with the key; turn the micrometric ring nut (N) anti-clockwise (as shown) until the green arrow (K1) illuminates to show that both tools are aligned.

5.3 Spring system for LASER (sidewinder) type keys

The clamp carriage on the MATRIX S key-cutting machine is provided with a spring system which controls the range of transversal movements, greatly assisting the cutting of Laser (sidewinder) keys. The spring system for Laser (sidewinder) keys is activated by means of the knob (O) (fig. 10). It determines lateral pressure on the part of the tools throughout the cutting operation; this makes it possible for the operator to follow the outline of the cuts manually without having to exert cross pressure on lever (C).

fig. 10, fig. 11 and fig. 12 show three examples of the use of the spring system:

- central cutting
- right-hand cutting
- left-hand cutting

Central cutting

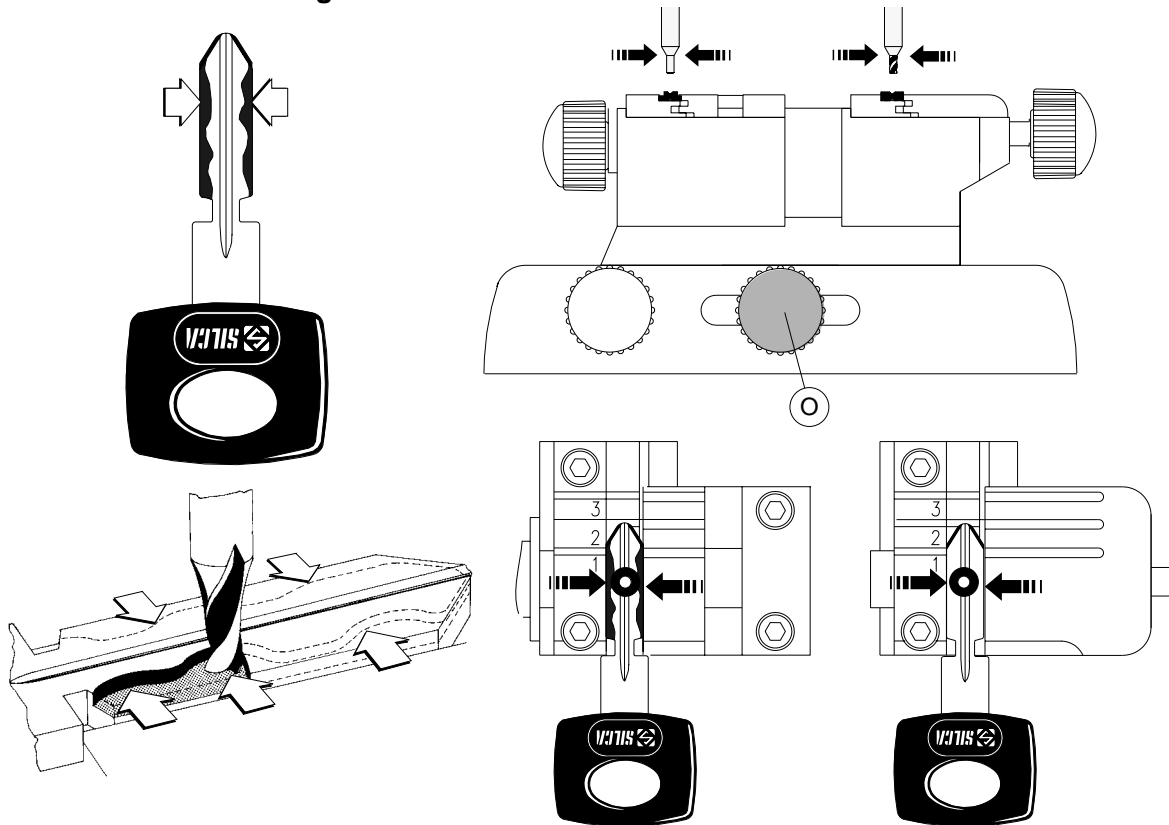

Fig. 10

Right-hand cutting

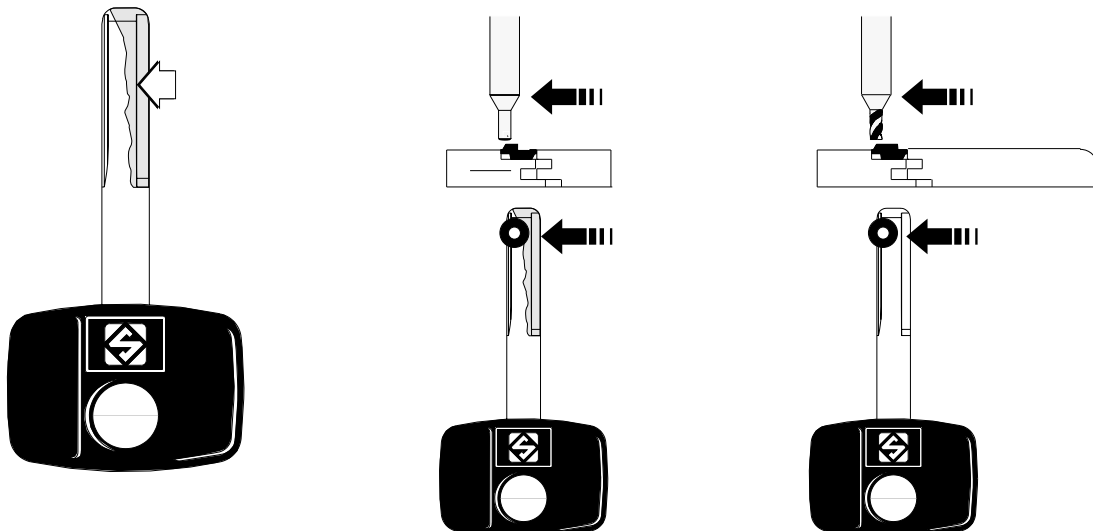

Fig. 11

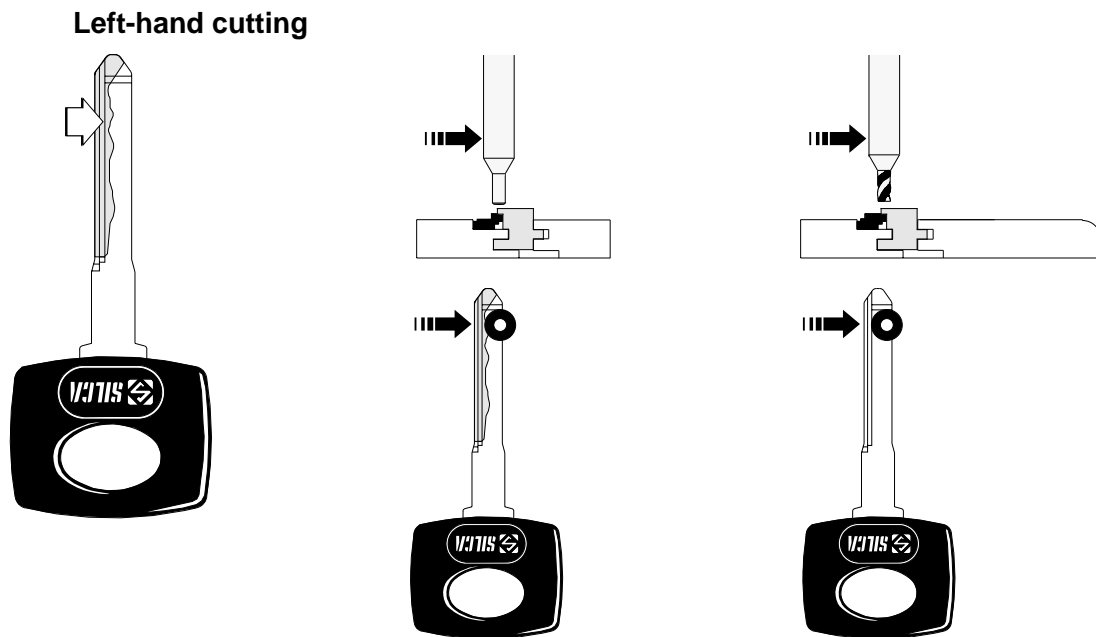

Fig. 12

REGULATING THE SPRING

- Loosen knob (O) slightly.

- **central cutting:**

take the cutter and tracer over the centre of the stems of the two keys (fig. 10).

- **right-hand cutting:**

take the cutter and tracer over the keys, positioning them to the left of the stems (fig. 11).

- **left-hand cutting:**

take the cutter and tracer over the keys, positioning them to the right of the stems (fig. 12). Tighten knob (O) and carry out cutting operations.

5.4 Clamps

The clamps are provided with special key-locking jaws (B4) and (B5) which can be easily changed if damage, without replacing the whole clamp unit.

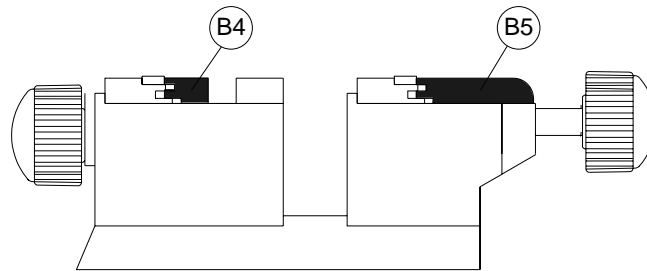

Fig. 13

5.5 Micrometric ring nut

The micrometric ring nut not only assists alignment of the tools, but it can also be used to correct the small depth variations found on worn keys.

After aligning the tools (green arrow K1) the depths of the cuts can be increased or reduced by turning the micrometric ring nut (N) to the right or left.

Each notch on the ring nut corresponds to an increase of 0,02 mm.

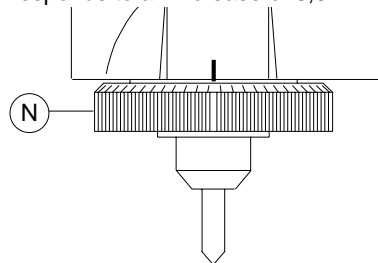

Fig. 14

5.6 Hand rest

The hand rest (R) on the left-hand side of the machine must be regulated by the operator to his/her hand size. To regulate the position of the hand rest, proceed as follows:

- 1) loosen the grub screw (R1) (fig. 15).
- 2) turn the hand rest and ring nut (R2) simultaneously to the required position.
- 3) tighten the grub screw (R1).

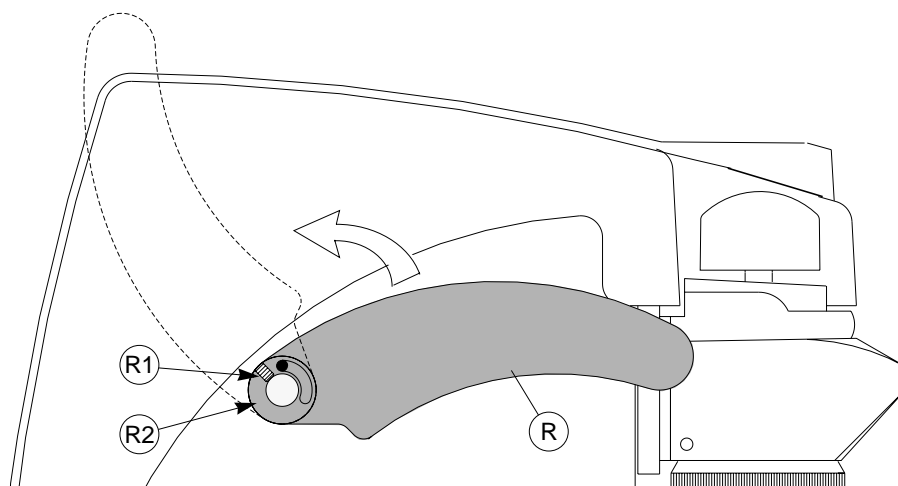

Fig. 15

6 CUTTING OPERATIONS

ATTENTION: for complete safety during the cutting operations, take the following precautions:

- Always work with dry hands.
- Check that the machine is properly earthed.
- Wear protective goggles even if the machine is provided with a safety shield over the cutting tool.
- Before starting the motor (switch Q), carry out the following operations:
 - place the keys in the clamps
 - install the tools and gauge them.
- Keep hands away from the cutting tool in motion.

6.1 Fitting the keys

- 1) Switch on the machine with the master switch on the back.
- 2) Take the clamp carriage towards the operator until it meets the end of run.
- 3) Place the original key into the left-hand jaw and the keyblank into the right-hand jaw, paying attention to the type of stop on the key (ch. 6.2).

6.2 Key stop

The references 0-1-2-3 on the clamps should be used according to the type of stop on the key:

- 0: for keys with rear stop (fig. 16).
- 1-2-3: for keys with tip stop (fig. 16)

Stops 1 - 2 - 3 are selected according to the length of the key stem.

ATTENTION: the cutting run must always be confined within the surface of the clamp.

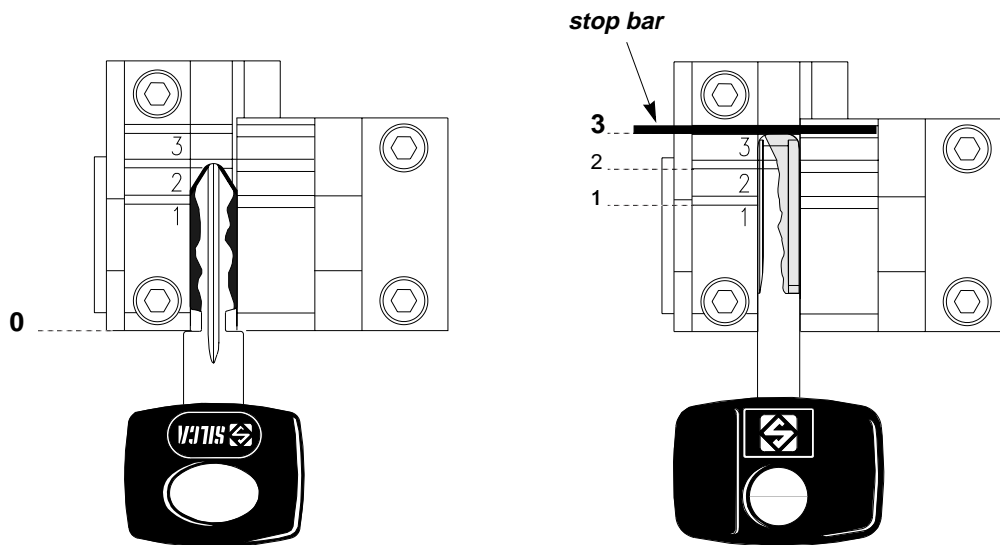

Fig. 16

- 1) Secure the keys with knobs (E) and (E1).
- 2) Activate the electromechanical setting checker and align the tools (ch. 5.2).

After placing the keys in the clamps, carry out the cutting operations following the instructions relating to the type of key to be cut (ch. 6.3 - Cutting dimple keys; ch. 6.4 - Cutting laser (sidewinder) type keys; ch. 6.5 - Cutting narrow-stemmed laser (sidewinder) type keys (art.HU41P-HU55P-HU61P etc.); ch. 6.6 - Cutting keys for Fichet.

6.3 Cutting dimple keys

- 1) Turn on switch (Q).
- 2) Grip the levers (C) and (I) and cut the key, first centering the tracer point on the hole on the original key then taking the cutting tool up to the keyblank.

6.3.1 Cutting the back

If cuts are to be made on the back, place the key in a vertical position (fig. 17).

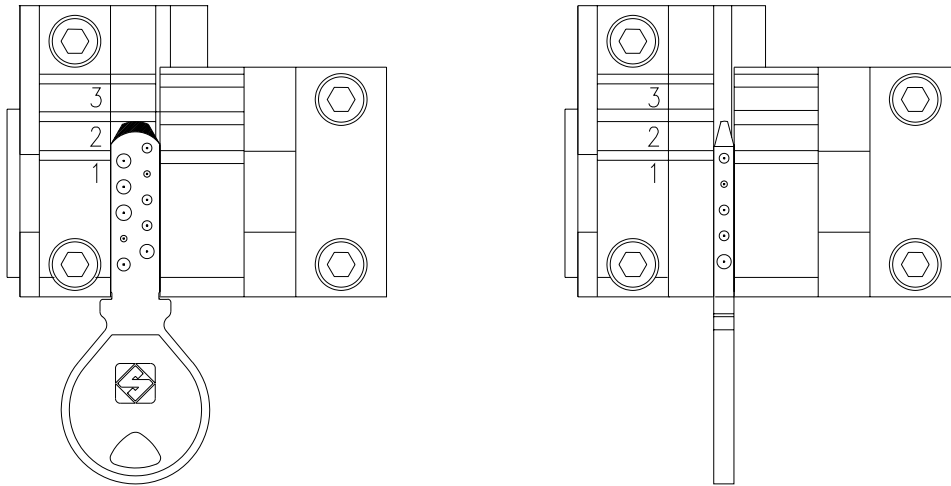

Fig. 17

6.4 Cutting laser (sidewinder) type keys

- 1) Before activating the start switch (Q), lower lever (I) close to the keys and regulate the spring system for laser (sidewinder) keys (ch. 5.3) with knob (O).
- 2) Start the cutting operation by activating switch (Q).
- 3) Lower the spindle, cut the key and stop at the beginning of the cut (fig. 19).
- 4) secure the spindle at this height by turning the lever (I) clockwise (fig. 18).
- 5) carry out the cuts using only the left-hand lever (C).

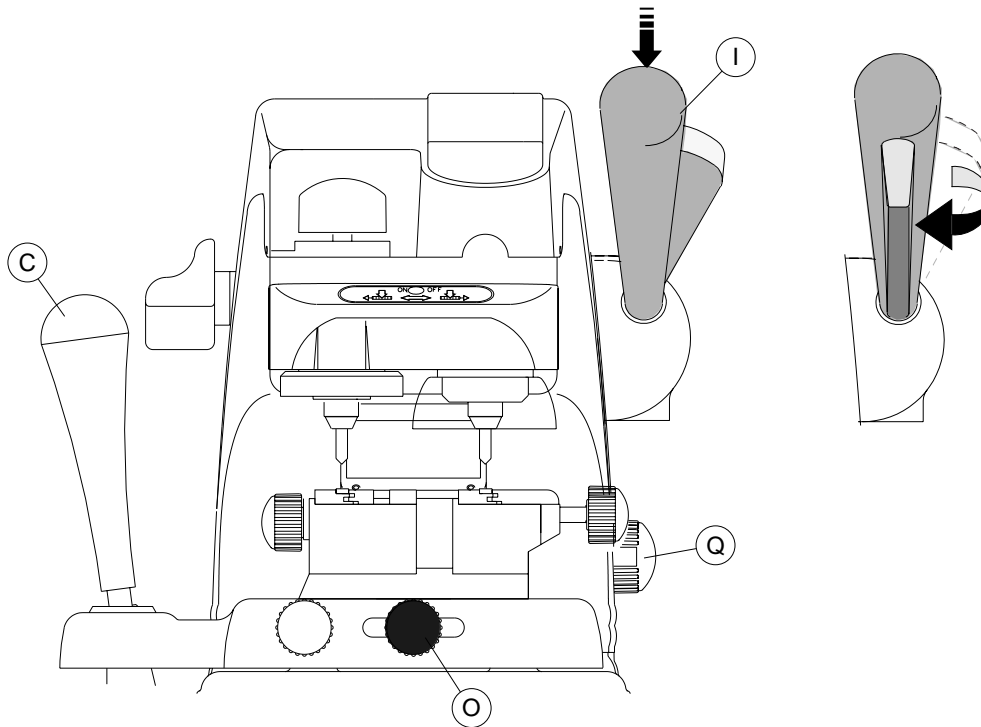

Fig. 18

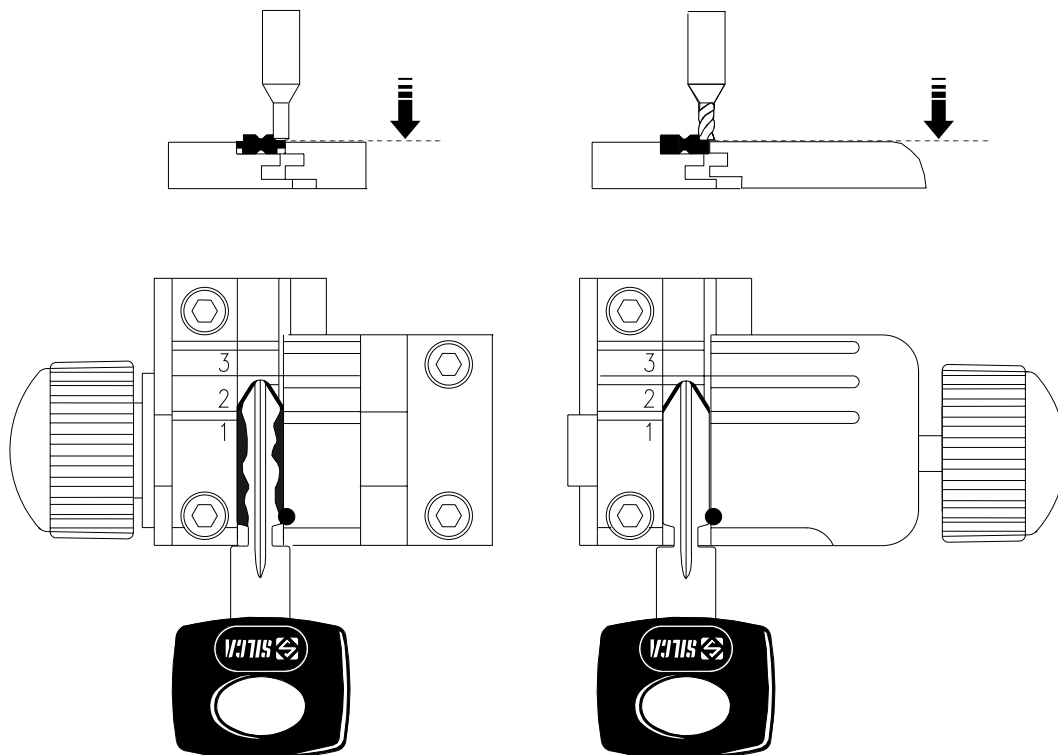

Fig. 19

6.5 Cutting narrow-stemmed laser (sidewinder) type keys (art.HU41P-HU55P-HU61P etc.)

The clamp can also be used to cut narrow-stemmed Laser (sidewinder) keys by simply fitting the adapter provided (ch. 3 - ACCESSORIES PROVIDED). The procedure is as follows:

- 1) open the clamps by loosening knobs (E) and (E1).

art. HU41P, HU64P:

- 2) place the adapter on the left-hand jaw and align the notch with "stop 2" (fig. 21-A).

art. HU55P:

- 3) place the adapter on the left-hand jaw and align the notch with "stop 3" (fig. 21-B).
- 4) place the stop bar into the groove.
- 5) insert the key so that it butts against the bar.
- 6) secure the adapter and key by tightening knob (E).
- 7) remove the bar and repeat the same operations on the right-hand jaw.

Cutting:

- 1) before activating the start switch (Q), lower lever (I) close to the keys and regulate the spring system for laser (sidewinder) keys (ch. 5.3).
- 2) Start the cutting operation by activating switch (Q).
- 3) lower the spindle, cut the key and stop at the beginning of the cut (ch. 6.4).
- 4) secure the spindle at this height by turning the lever (I) clockwise (fig.18, page 26).
- 5) carry out the cuts using only lever (C).

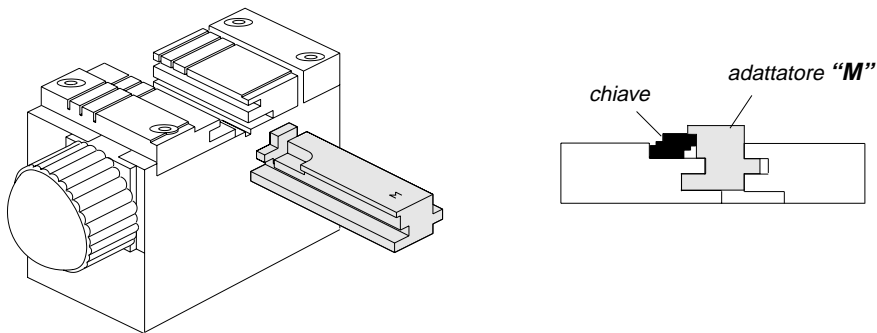

Fig. 20

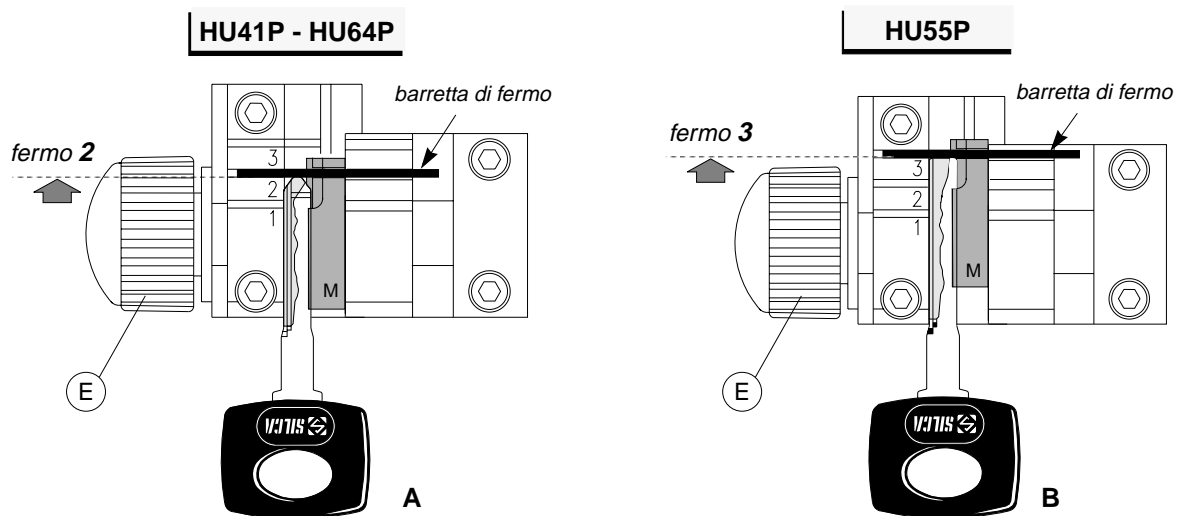

Fig. 21

6.6 Cutting keys for Fichet

The clamp can also be used to cut keys for FICHET (H profile) by simply fitting the adapter provided (ch. 3 - ACCESSORIES PROVIDED). The procedure is as follows:

- 1) open the clamps slightly by loosening knobs (E) and (E1) (fig. 23).
- 2) place the adapters all the way into the clamps.
- 3) place the keys with the stop up against the adapter.
- 4) secure the adapters and keys by tightening knobs (E) and (E1).

Cutting:

- 1) activate the Laser (sidewinder) key spring system with knob (O) (ch.5.3, page 21).
- 2) turn on switch (Q), lower the collet assembly and position on the beginning of the cut (ch. 6.4).
- 3) secure the spindle at this height by turning the lever (I) clockwise (fig.18, page 26).
- 4) carry out the cuts using only lever (C).

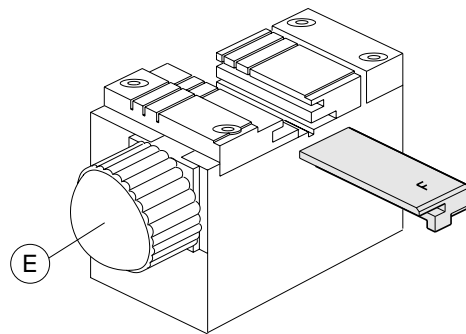

Fig. 22

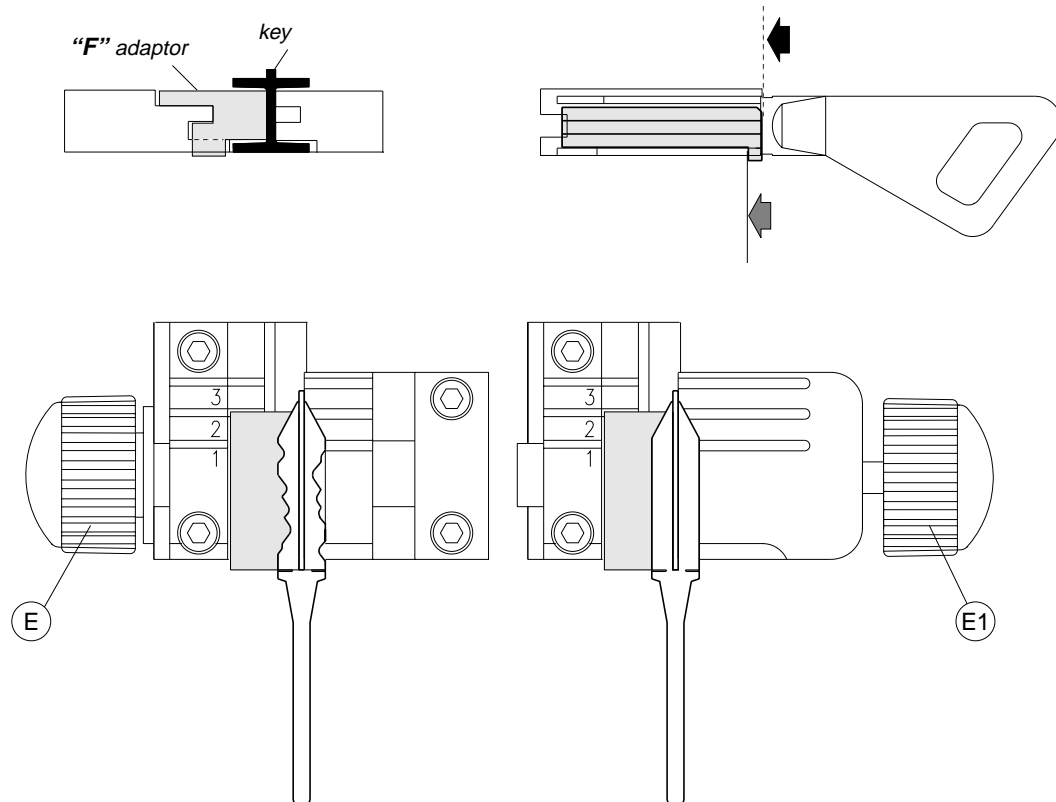

Fig. 23

7 MAINTENANCE

ATTENTION: for repairs or replacement of parts for maintenance, the 'CE' mark is guaranteed only if original spare parts provided by the manufacturer are used.

Although the MATRIX S key-cutting machine does not require special maintenance, it is advisable to check and, if necessary, replace the parts subject to wear, such as:
the belt (ch. 7.1), the lamp (ch. 7.2) and tension spring on the vertical carriage (ch. 7.3).

Replacement is simple and can be carried out by the operator.

CLEANING: keep the carriage and clamps free of chippings from the cutting operations by cleaning with a dry brush.

ATTENTION: do not use compressed air!

Before starting any type of maintenance (checks or replacements), read the instructions below:

- never carry out maintenance or servicing with the machine switched on.
- always remove the mains plug.
- follow all the instructions in the manual to the letter.
- use original spare parts.

7.1 Replacing the belt and adjusting tension

If the upper part of the machine vibrates, check the tension on the belt, as described below:

- 1) turn off the master switch and remove the mains plug.
- 2) loosen the four screws (Y1) and remove the upper casing (Y) (fig. 24).
- 3) loosen (but do not remove) the four socket head screws (Y2) securing the motor.

Tension:

- increase belt tension by pushing the motor towards the back of the machine.

Replacement:

- 1) loosen the belt by pushing the motor slightly towards the tracer point and cutting tool.
- 2) remove the belt and replace.
- 3) tighten the tension by pushing the motor towards the back of the machine.
- 4) secure the motor by tightening the four socket head screws (Y2).
- 5) replace the upper casing (Y) and secure with the four screws (Y1).

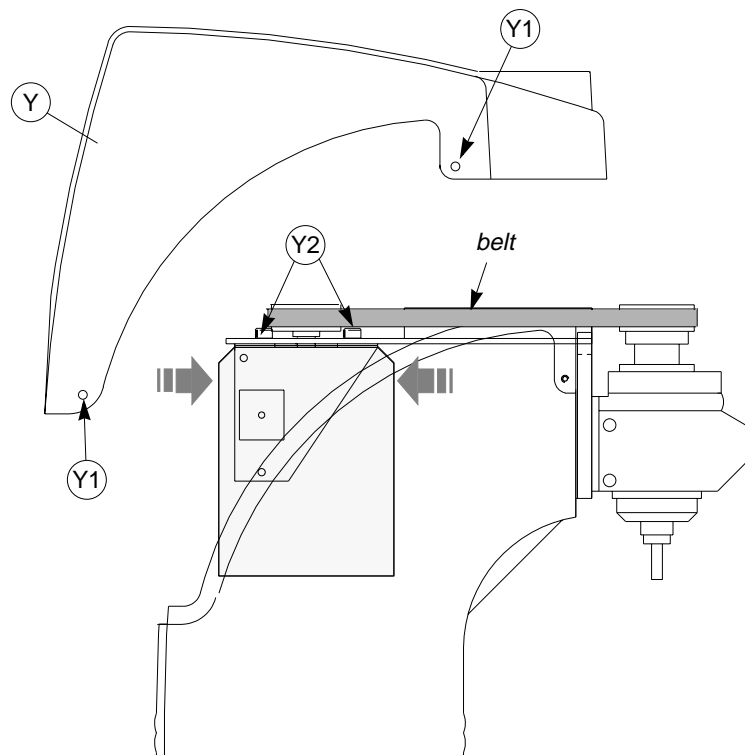

Fig. 24

7.2 Replacing the light bulb

To replace the light bulb:

- 1) turn off the master switch and remove the mains plug.
- 2) remove the four screws (J1) which secure the glass cover (fig. 25).
- 3) unscrew the light bulb and remove.
- 4) install the new light bulb and replace the glass cover with the four screws (J1).

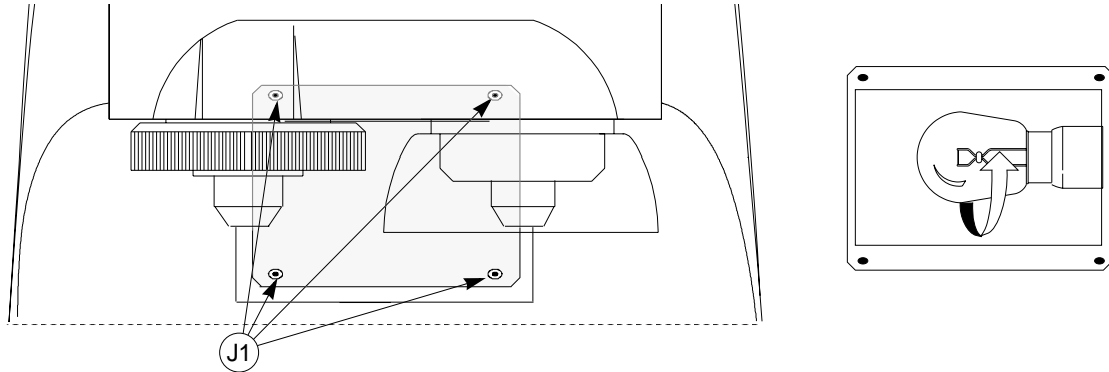

Fig. 25

7.3 Registration/replacement of the vertical carriage tension spring

If the vertical carriage (Z axis) movements betray a lack of tension, it is advisable to register the spring or, if necessary, replace it. Proceed as follows:

- 1) turn off the master switch and remove the mains plug.
- 2) loosen the four screws (Y1) and remove the upper casing (Y) (fig. 26-A).
- 3) turn the machine round with the rear towards the operator.
 - to increase spring tension: observe the illustration 1 and 2 in fig. 26-B.
 - to reduce spring tension: observe the illustration 1 and 2 in fig. 26-C.
- 4) replace the upper casing (Y) and secure with the four screws (Y1).

To replace the spring:

- follow the instructions in 1, 2, 3, above, replace the spring and regulate tension.

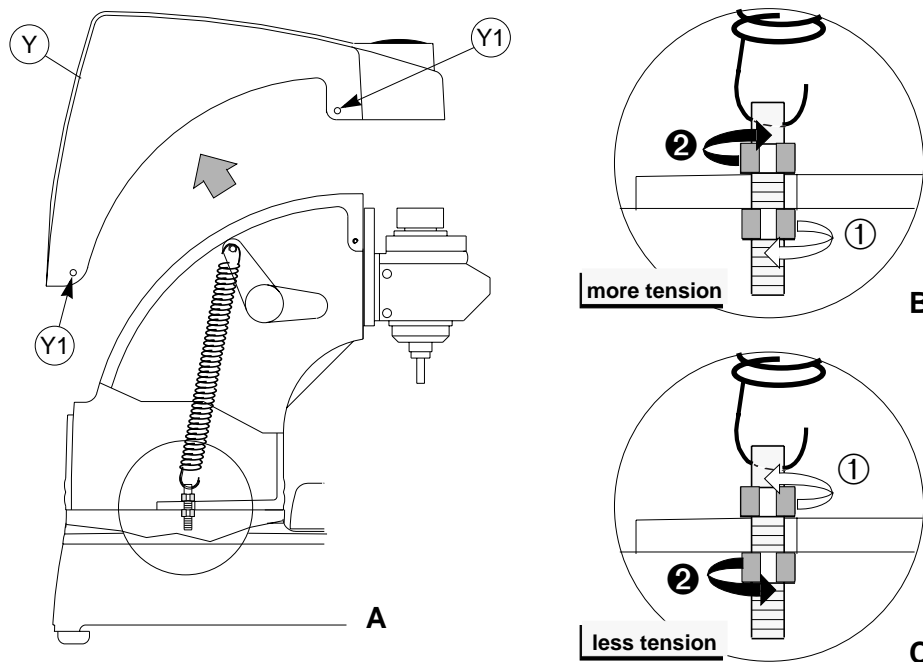

Fig. 26

7.4 Checking and replacing the fuses

The fuses should always be checked with a continuity measuring instrument (tester, ohmmeter, multimeter etc.) as a visible check may not reveal an electrical fault. Fuses must always be replaced with others of the same type (rapid or delayed) and with the same Amps, as shown in the manual.

The MATRIX S key-cutting machine has two fuses:

- **2 Amps rapid for machines with 230 Volts**
- **3,15 Amps rapid for machines with 115 Volts**

placed in the inlet socket next to the master switch (P) (fig. 27), to protect the key-cutting machine from sudden changes in voltage or short circuits.

It is advisable to check the fuses if the machine is not activated by turning on the master switch. Proceed as follows:

- 1) turn off the master switch (P) and remove the mains plug.
- 2) remove the fuse board with the aid of a screwdriver (fig. 27).

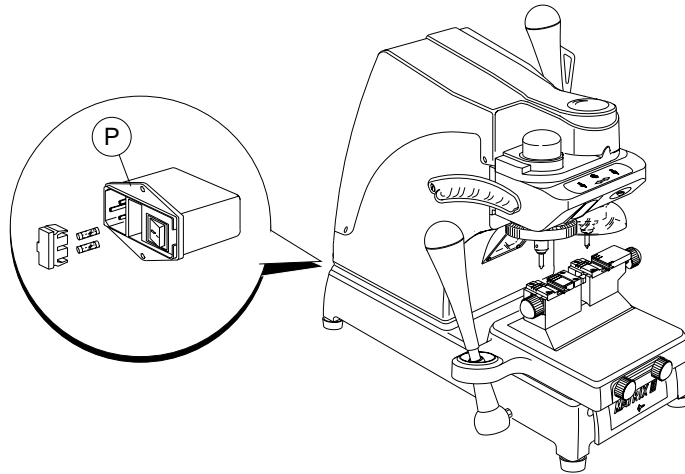

Fig. 27

7.5 Replacing the electronic board for the keypad

If the keypad (K) is not working properly, replace the internal electronic board. Proceed as follows:

- 1) turn off the master switch and remove the mains plug.
- 2) remove the four screws which secure the template (Z4) and remove.
- 3) disconnect the connector (Z3).
- 4) remove the adhesive label (K) and unscrew the two screws securing the board.
- 5) replace the board, secure with the two screws and reconnect the connector (Z3).
- 6) re-position the template on the machine, secure with the four screws and attach the adhesive label/display (K).

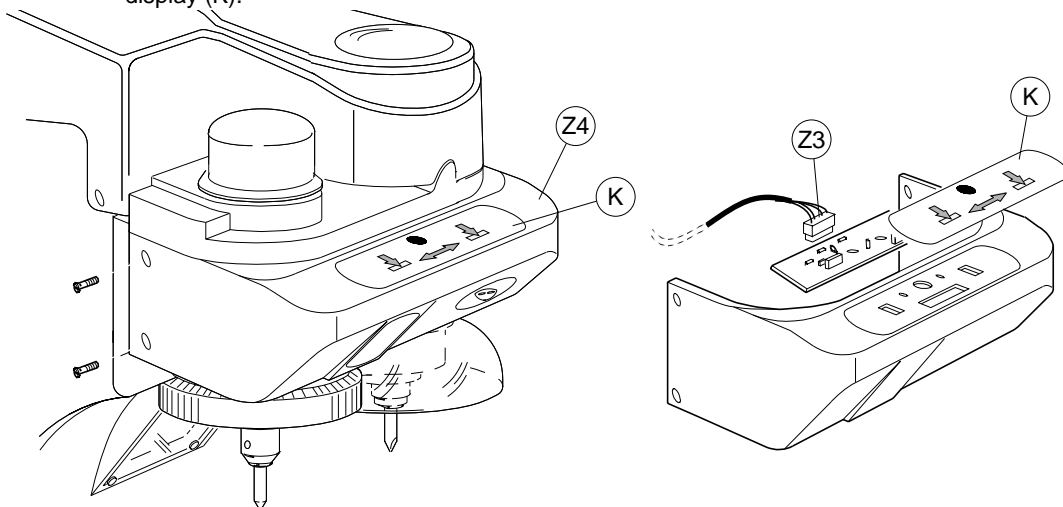

Fig. 28

8 WASTE DISPOSAL

EU regulation establish special arrangements for the disposal of waste (*).

Waste deriving from cutting operations

Although residue coming from the key-cutting operations is classified as special waste, it is included in solid urban waste (SUW) as metal wool.

Such waste is sorted according to its classification under current Italian and EU law and consigned to the proper disposal units.

Cases where waste can be considered contaminated or containing toxic/harmful substance sufficient to transform it from SUW to toxic/harmful waste, are listed in the enclosures to current Italian and EU waste disposal regulations.

Cutting machine

The MATRIX S key-cutting machine is designed for many years of operations and is also re-usable. Recycling is a recommended ecological practice.

Packing

The MATRIX S is consigned in a cardboard packing box which can be re-used if undamaged. When it is to be thrown away it is classified as solid urban waste and should be placed in the special paper collecting bins.

The protective shell containing the machine is in polymer, classified as SUW, and can therefore be placed in an ordinary waste bin.

(*) "Waste" is any substance or object deriving from human activity or natural cycles, thrown away or to be thrown away

9 ASSISTANCE

Silca provides full assistance to purchasers of the MATRIX SX key-cutting machine.

To ensure complete safety for the operator, an job not specified in this manual should be carried out by the manufacturer or in the special Service Centres recommended by Silca.

On the back cover of the this manual is a list of the manufacturer's addresses; listed below are the addresses of specialised Service Centres.

9.1 How to request service

The guarantee attached to MATRIX SX key-cutting machine ensures free repairs or replacements of faulty parts within six months of purchase. All other service calls must be arranged by the customer with Silca or with Silca Service Centre.



SILCA S.p.A.
Via Podgora, 20 (Z.I.) 31029 VITTORIO VENETO (TV)
Tel. 0438 9136 Fax 0438 913800
www.silca.it

Member of the Kaba Group

