

KD50A

INSTRUCTION MANUAL

IMPORTANT! Read these instructions before you use your new KD50A Key Machine.

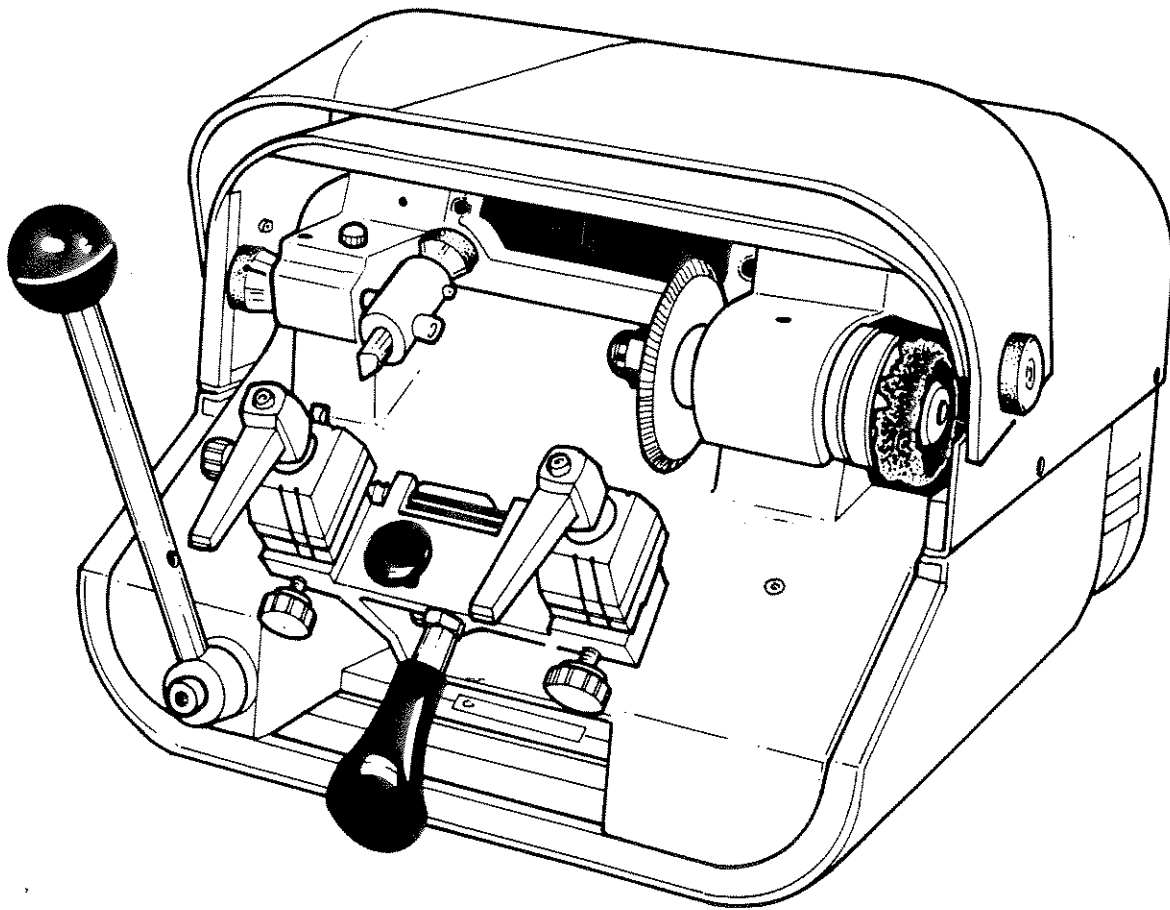

ILCO UNICAN

USA: 400 Jeffreys Rd., P. O. Box 2627, Rocky Mount, NC 27802-2627 • Tel: (919) 446-3321 • FAX: (919) 446-4702
EXPORT: 7301 Decarie Blvd., Montreal, Que. H49 2G7 • Tel: (514) 735-5411 • Telex: 05-827733 • FAX: (514) 273-3521



This manual is registered and applies specifically to the machine which carries this serial number. It properly identifies your model and assures you will receive correct parts, if and when you require replacement parts. Retain this manual in a safe place. It's the only one of its kind. If ownership of this machine is transferred, this

service manual should accompany the machine.

When seeking service information about this machine, refer to the Model No. (which is KD50A), your registration number (see below) and the part number desired (see pages 4 to 9). Note that most parts are interchangeable with the previous model (KD50).

CONTENTS

Warranty	2
Introduction (to the KD50A)	3
Operating Parts (Illustrated)	4
Operating Parts Identification (Names and Part Numbers)	5
Exploded View Parts List (Names and Part Numbers)	6-7
Exploded View of Parts	8-9
The Cutting Operation, Proper Key Cutting Techniques	10
Adjusting for proper depth of cut	11
Adjusting for proper lateral distance (spacing)	11-12
Aligning keys with shoulders	13
Aligning keys without shoulder (Ford and Best)	13
Aligning narrow blade cylinder keys	14
Aligning double sided cylinder keys	14
Aligning carriage to prevent vise jaw damage	15
Replacements (cutter, belt, key guide cylinder, spacing, depth)	16

ONE YEAR LIMITED WARRANTY

ILCO UNICAN warrants to the original buyer of any new model KD50A machine that it will repair or replace, at its option, any part of any machine which proves, to the reasonable satisfaction of ILCO UNICAN, to have defects arising from the faulty manufacture of the machine or from defective material or components, during a period of one (1) year from the date of shipment of the machine by ILCO UNICAN, provided that the machine is returned by prepaid transport to ILCO UNICAN or to its authorized representative before the expiry of the warranty period together with a detailed description of the alleged defect(s). ILCO UNICAN may, at its discretion, elect to refund the purchase price allocable to the part affected, or to issue a credit if the price therefore remains unpaid.

ILCO UNICAN sells precision-made machines. The buyer assumes all risks, and ILCO UNICAN shall not be liable for any reason, if the machine has been subjected to improper installation, improper use, improper or inadequate maintenance, negligence, if any unauthorized modification or alteration is made to the machine, or in case of accident. For greater certainty, any machine not operated in accordance with ILCO UNICAN's printed instructions or operated beyond its rated capacity shall

not be covered by this or any other warranty.

Any and all warranties made by ILCO UNICAN on any machine, product, or component thereof shall be effective only if and for so long as the buyer complies with all payment obligations pursuant to the buyer's accepted and acknowledged order. Failure to meet such payment obligations shall void all warranties and not extend the period of time for which such machine, product or component thereof is warranted irrespective of whether or not payment is eventually made.

These warranties are in lieu of and not in addition to any other warranty of condition, expressed or implied, including without limitation merchantability, fitness for a particular purpose or latent defects. The buyer releases ILCO UNICAN from any liability for any reason other than a breach of its warranties hereunder.

The liability of ILCO UNICAN shall in no case, including negligence, exceed the purchase price of the defective machine, nor shall ILCO UNICAN be liable for any personal injuries, property damage or consequential damages.

Use only genuine ILCO UNICAN replacement parts on this machine!

Registration and Serial number is _____

Congratulations! You've purchased a superior key cutting machine.

The KD50A key machine you've just received will give you remarkably fast and accurate key cutting for many years to come ... and a profitable return on your investment. It will save you time and money.

The KD50A is superbly engineered and built with uncompromising quality for the professional who is really serious about speed, accuracy and profitability. This advanced machine incorporates design and operating features that let you cut keys faster, more precisely and more profitably than most machines on the market. You can now cut a key **accurately** within 5 seconds - that's faster than most automatics!

Technically, the machine you've just purchased is called a key duplicator; it transfers and duplicates cuts from your customer's key onto a key blank. It's designed to

cut the **most popular** types of keys - the standard house, car and padlock key (called cylinder keys by the trade).

Your new key machine is not like conventional key cutting machines which require tedious manual positioning and movement of the entire carriage. Instead, it features a lever design which moves the entire carriage with a quick, effortless motion. You merely position the lever and carriage to line up for the first cut, and move the lever laterally (sideways).

A special cobalt steel cutter mills away the blank quickly, assuring a cut that is accurate. To further speed and to simplify key cutting, the KD50A has extra wide reversible jaws. There's enough space between the jaws to cut even the long, large bow hotel keys. And the reversible jaws will hold Schlage wafer or double sided import car keys securely for trouble-free cutting.

UNPACKING INSTRUCTIONS

Your new KD50A key machine has been shipped to you in a sturdy, specially cushioned container to prevent the possibility of damage during handling and shipment.

Once the machine is removed from the carton, it should be set up on a level workbench and wiped free of all

rustproofing oil. The machine is adjusted at the factory and test keys have been cut on it, but it is recommended that you check the adjustments to make sure they have not slipped or shifted during transit (See Pages 16 "SPACING AND DEPTH ADJUSTMENT").

CAUTION! DO NOT DESTROY OR DISCARD THIS VALUABLE SHIPPING CARTON. STORE IT CAREFULLY IN A SAFE PLACE. IN THE EVENT OF A PROBLEM WITH YOUR MACHINE, IT MUST BE RETURNED TO OUR SERVICE FACILITY IN ITS ORIGINAL PROTECTIVE CARTON.

OPERATING PARTS

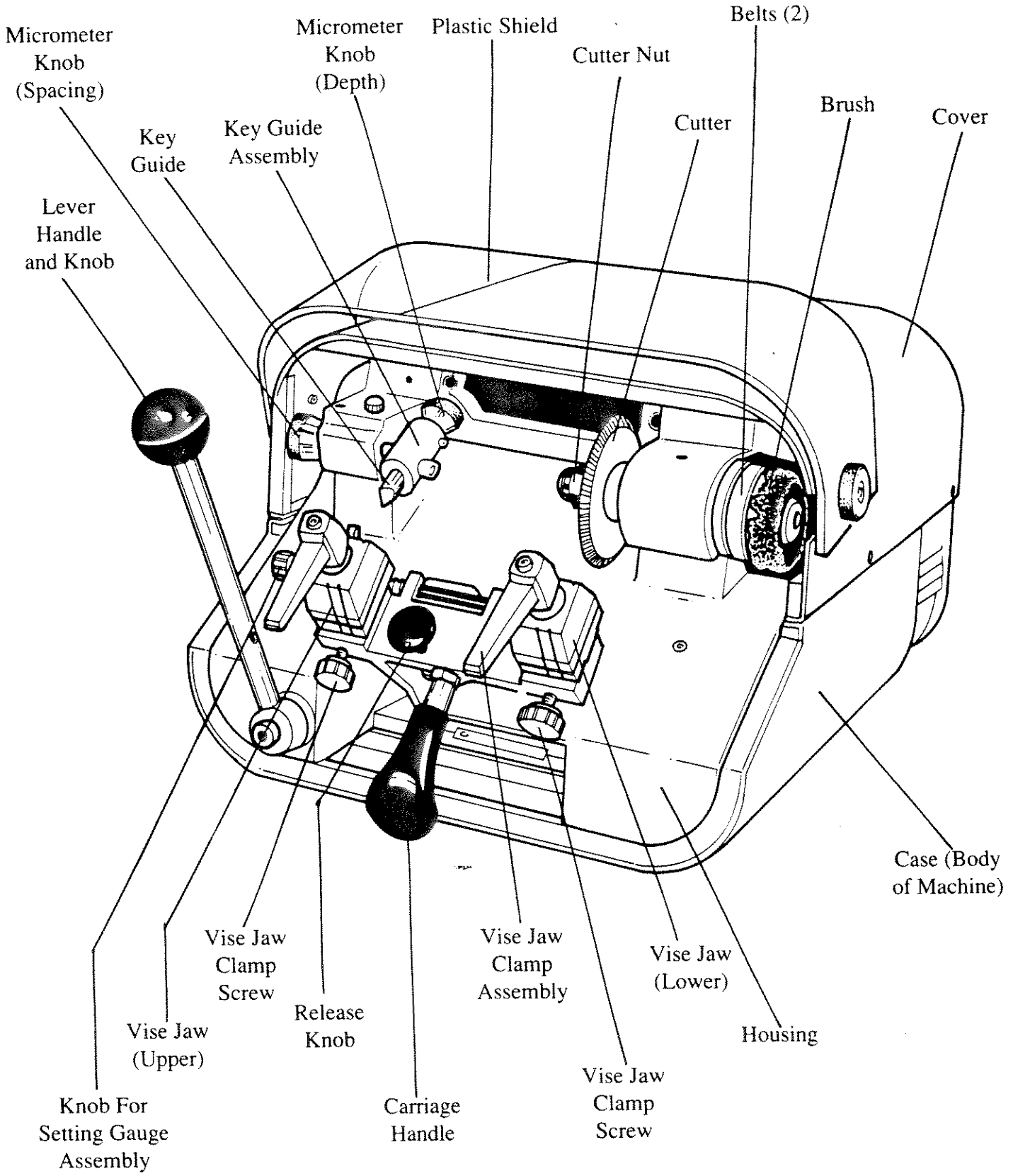

NOTE: On/Off power switch (KD50A-15) is not shown, but is visible on the left side of the machine.

OPERATING PARTS IDENTIFICATION

Refer to page 4.

Part No.	Identification
KD50A-1A	Housing
KD50A-2A	Case (Body of Machine)
KD50A-4A	Cover
KD50A-8A	Belt (two)
KD50A-15	On/Off power switch (not shown)
KD50A-31	Lever Handle
KD50A-32	Knob
KD50A-51	Clamp Screw, vise jaw (two)
KD50A-53	Upper vise jaw (two)
KD50A-54	Lower vise jaw (two)
KD50A-58	Clamp Assembly, vise jaws (two)
KD50A-62	Carriage Handle
KD50A-68	Knob, setting gauge assembly
KD50A-72	Release knob
KD50A-86	Key Guide Assembly
KD50A-89	Key Guide
KD50A-96	Cutter Nut
KD50A-102B	Brush
KD501-104	Plastic Shield
KD501-150	Micrometer adjusting knob
CU50A	Cutter, 3,150" diameter, cobalt steel

EXPLODED VIEW PARTS LIST

Refer to pages 8 and 9 for illustrations.

Part No.	Description	Part No.	Description
KD50A-1A	Housing	KD50A-50	Jaw Post Retainer
KD50A-2A	Case (Body of Machine)	KD50A-51	Clamp Screw (Jaw Post)
KD50A-3A	Back Plate	KD50A-52	Jaw Spring
KD50A-4A	Cover	KD50A-53	Upper Vise Jaw
KD50A-5	Motor Shelf	KD50A-54	Lower Vise Jaw
KD50A-6A	Bracket, Motor Support	KD50A-55	Left Post
KD50A-7A	Motor Pulley	KD50A-56	Right Post
KD50A-8A	Belt (for Italian Motor)	KD50A-57	Retaining Washer, Right Post
KD50A-9A	Motor (110V 60Hz)	KD50A-58	Clamp Assembly (Vise Jaws)
KD50A-10	Power Cord and Plug	KD50A-59	Thrust Washer
KD50A-11	Bushing, Strain Relief	KD50A-60	Key Head Rest
KD50A-12	Terminal	KD50A-61	Clamp Screw (Block)
KD50A-13	Grounding Stud	KD50A-62	Carriage Handle
KD50A-14	Grounding Nuts	KD50A-64	Finger, Setting Gauge
KD50A-15	On/Off Switch, Rocker Type	KD50A-66	Spring, Setting Gauge
KD50A-16	Power Cable	KD50A-67	Shaft, Setting Gauge
KD50A-17	Light Socket	KD50A-68	Knob, Setting Gauge
KD50A-18	Light Bulb	KD50A-69	Sleeve, Setting Gauge
KD50A-19	Socket Support Bracket	KD50A-70	Pin, Setting Gauge
KD50A-20A	Transparent Light Guard	KD50A-71A	Shaft, Detent Release
KD50A-21	Momentary Switch - N. O.	KD50A-72	Knob, Detent Release Shaft
KD50A-23A	Carriage	KD50A-73A	Sleeve, Detent Release Shaft
KD50A-24A	Carriage Shaft	KD50A-74	Extension Arm (Sleeve)
KD50A-25	Actuating Shaft	KD50A-75	Retraction Wire Plate
KD50A-26	Drive Shaft	KD50A-76	Retraction Wire, Setting Gauge
KD50A-27	Retaining Collar	KD50A-77	Spring, Detent Release
KD50A-28	Actuating Shaft Sleeve	KD50A-81	Pawl
KD50A-29	Gear	KD50A-82	Pivoting Block Shaft
KD50A-30	Washer (Brass)	KD50A-83A	Spacer Sleeve
KD50A-31	Handle	KD50A-84	Carriage Shaft Detent Sleeve
KD50A-32	Knob	KD50A-85	Spring, Pivoting Block
KD50A-34	Plate	KD50A-86	Key Guide Assembly
KD50A-35	Angle Plate	KD50A-87	Mounting Cylinder
KD50A-36	Brass Bearing Block	KD50A-88	Barrel
KD50A-37	Brass Bearing Spacer	KD50A-89A	Key Guide
KD50A-38	Angle Pin	KD50A-90	Adjusting Screw Bushing
KD50A-39	Carriage Spring	KD50A-91A	Adjusting Screw (Diametral)
KD50A-40	Cam Actuating Pin	KD50A-92A	Adjusting Screw (Lateral)
KD50A-45	Mounting Block Switch	KD50A-95	Cutter Spindle
KD50A-46	Cutter Starting Switch	KD50A-96	Cutter (Acorn) Nut

EXPLODED VIEW PARTS LIST

Refer to pages 8 and 9 for illustrations.

Part No.	Description	Part No.	Description
KD50A-97	Cutter Washer	KD50A-121	Box for Service Kit
KD50A-98	Bearing	KD50A-136	Pin Retainer
KD50A-99	Bearing Spacer, External	KD50A-138	Motor Support Bracket Retainer
KD50A-99IN	Bearing Spacer, Internal	KD50A-139	Grounding Label
KD50A-100	Pulley, Cutter Spindle	KD50A-141	Switch Cam
KD50A-101	Spacer Washer, Brush	KD50A-142	Switch Operating Shaft
KD50A-102B	Brush, 3" Nylon	KD50A-143	Pin Spring (not shown)
KD50A-103	Shoulder Screw, Brush	KD50A-144	Carriage Stop
KD50A-104	Plastic Shield	KD50A-145	Carriage Stop Screws
KD50A-105	Shield Knob	KD50A-146	Carriage Stop Adjusting Screw
KD50A-107	Foot	KD50A-147	Carriage Stop Adjusting Nut
KD50A-108	Spacer, Foot	KD50A-150	Micrometer Knob
KD50A-109A	Chip Pan	KD50A-160	Three Terminal Switch
KD50A-111	Service Bar	KD50A-161	On/Off Switch Plate
KD50A-112	Service Pin, 1.2mm	KD50A-J	Vise Jaw Assembly (set)
KD50A-113	Service Pin, 1.7mm	KD50A-R	Release Mechanism
KD50A-114	Hex Wrench Set (2, 2.5, 3, 4, 5, 6mm)	KD50A-S	Setting Gauge Assembly
KD50A-115	Open End Wrench	CU50A	Cutter (3.150" diameter, Cobalt Steel)
KD50A-116	Bar (to secure cutter spindle)	KD50A-IMD	Instruction Manual
KD50A-120	Service Kit		

OPERATING ACCESSORIES



Service Bar

Used to adjust spacing and depth. Also serves as stop for shoulderless keys.



Service Pins

Used as shims to raise narrow blade keys above surface of vise jaw.



Metric Allen Wrench

Various size wrenches are used to loosen and retighten set screws on the machine.



Metric Wrench

Used to loosen and retighten cutter nut and belt tension adjustment nut.



Cutter Spindle Bar

Used to hold cutter spindle rigid while removing cutter nut.

EXPLODED VIEW

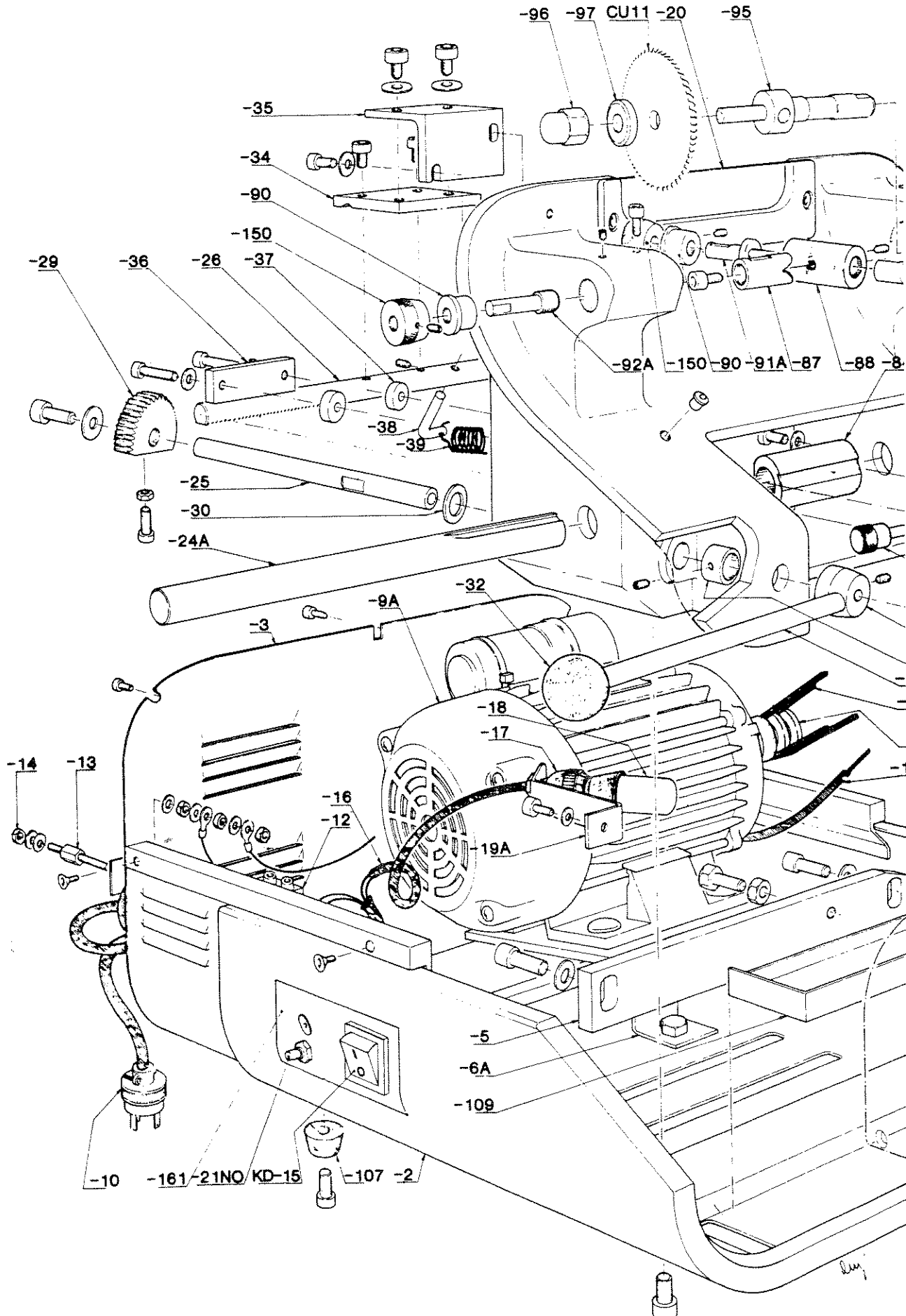

EXPLODED VIEW

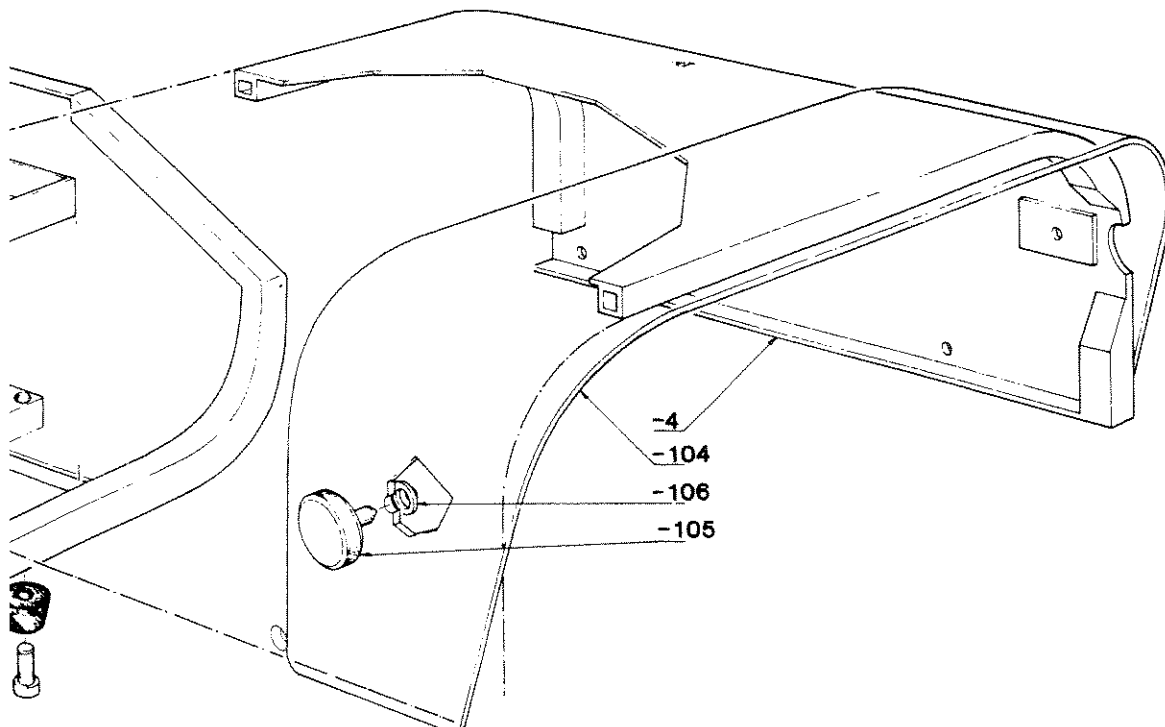
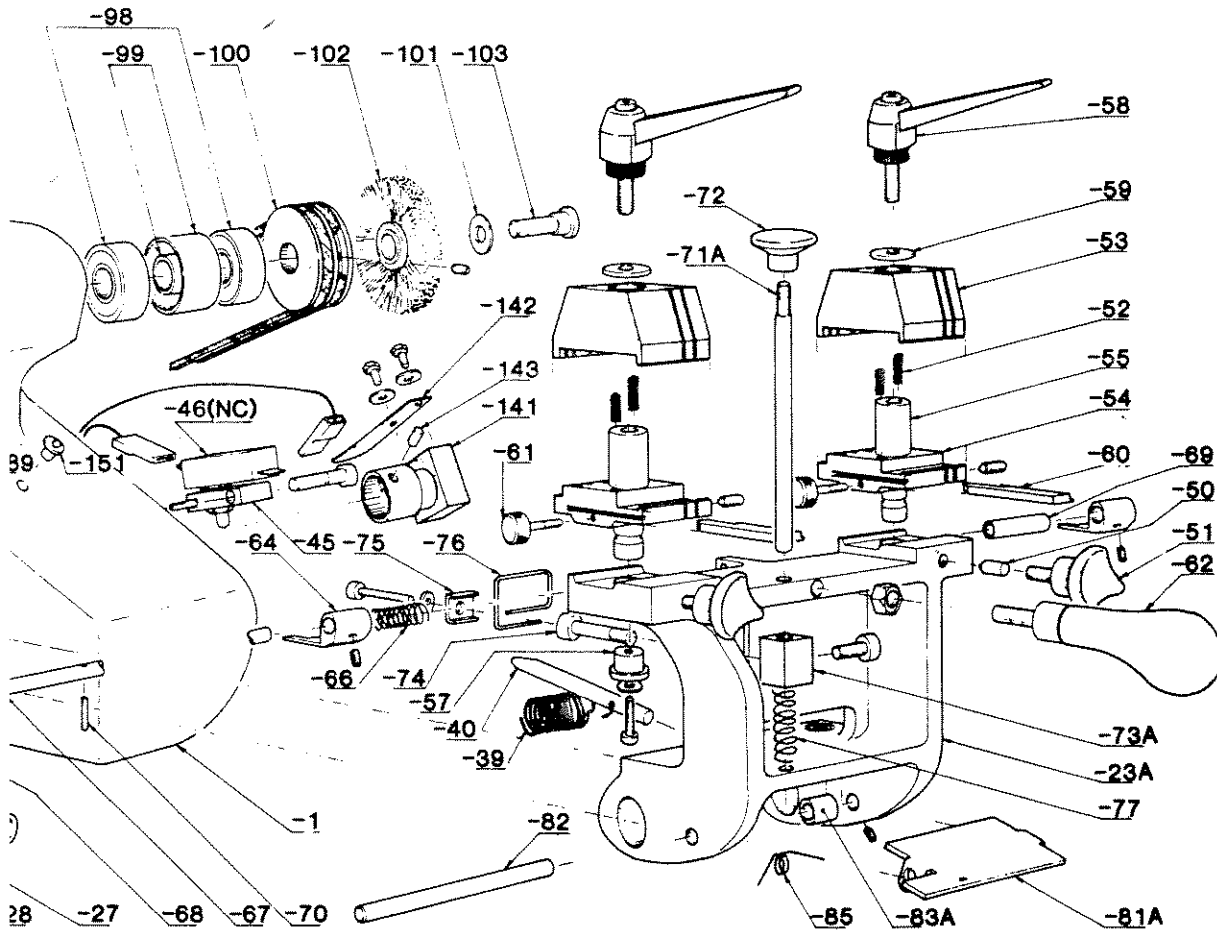

THE CUTTING OPERATION

GENERAL OPERATING SEQUENCE

The KD50A has a constant power switch which must be turned on. However, the machine motor will not operate until activated by the carriage assembly.

After both key and blank are properly clamped and aligned, pull down on the carriage handle. Use thumb to depress carriage release knob - the key setting gauge will automatically spring away. Spring tension will raise the carriage, and the motor will automatically start.

Move the lever handle sideways so that the original key touches the key guide in an area between the shoulder and the first cut. Do not let the shoulders touch either the key guide or cutter wheel. Using the lever handle, slide the carriage left and then right to complete the cutting operation. Lower the carriage until it locks into the original position, which will automatically stop the motor and cutter. Remove the new key and deburr with the brush; do not overbrush or run key into belts.

PROPER KEY CUTTING TECHNIQUES

Even though your KD50A key machine is designed to make key cutting fast, easy and accurate, operator skill is important. The actual mechanics of placing keys within the vise jaws are simple to learn, but there are some basics that must be followed. A properly adjusted key machine, used by someone who ignores good key cutting techniques, will **NOT** produce a good key. The way a person clamps a key into the vise jaws is critical to the accuracy of the duplicated key.

Remember - the real purpose of a duplicate key is simply to operate the lock for which it was intended. If your customers don't bring back the keys, you can assume the keys are cut correctly. If customers return the keys, you should re-examine your cutting techniques and adjustments of the machine.

Here are some important operating tips:

1. Vise jaws - clean them regularly so that no metal chips lie under the keys. **It is essential that both keys lie flat across the entire width of both vise jaws. Neither key should be tilted.**

2. Do **NOT** use pliers or other tools to tighten the vise jaws. Firm hand pressure is sufficient.
3. Keep the carriage shaft free of metal chips. A thin film of oil can be applied to it. The carriage should travel smoothly along its shaft.
4. **NEVER** touch the shoulder of a key to the side of the key guide. This will cause the shoulder of the key blank to touch the side of the cutting wheel. When this happens, some of the metal will be cut away from the shoulder of the key blank. If the resulting duplicated key is duplicated two, three, four times over, an error will accumulate and cause a non-operating key. Do not grind away the shoulder.
5. Don't run the cutter into the vise jaw; this will only dull the cutter, and reduce cutter efficiency.
6. Keep the cutter clean. Don't let any foreign objects or instruments blunt it. This cutter is a precise cutting tool and should be handled with care.
7. Lubricating of moving parts is important. Oil cups are provided to keep the cutter shaft bearings well lubricated. The carriage spindle should be lubricated with a thin film of oil.

ADJUSTING FOR PROPER DEPTH OF CUT

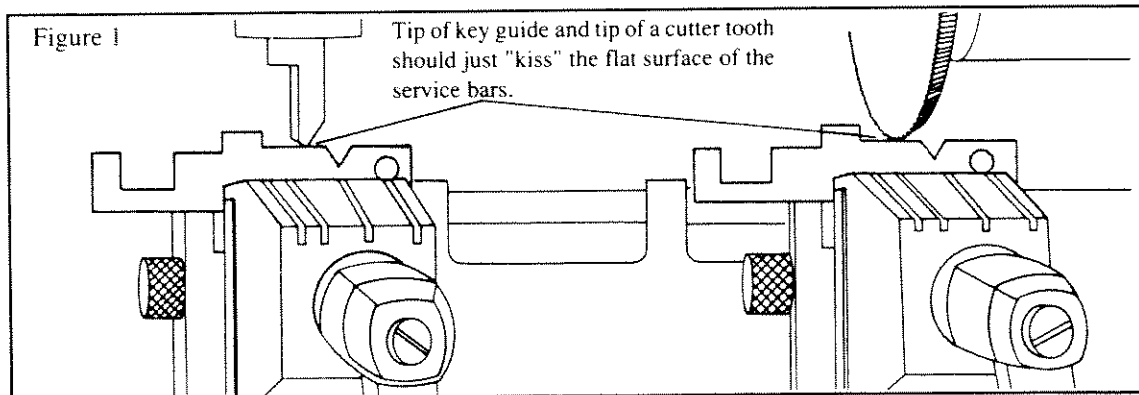

Remove the wire plug from its electrical socket for safety. Clamp the two service bars into the vise jaws as shown in Figure 1, making certain that both bars rest flat against the bottom of the vise and that they are butting against the edge of each vise jaw. Lift the carriage toward the key guide and cutter until a flat portion of the left service bar rests against the key guide. (To lift the KD50A carriage, pull down and press the carriage release button between the vise jaws.)

Turn the cutter by hand. The machine is correctly adjusted if the cutter barely grazes the top of the right service bar. If the cutter is stopped from turning or turns freely without contacting the service bar, the cutting depth must be adjusted, as follows:

1. Loosen the Allen screw that holds the key guide .
2. Turn the cutting depth micrometer adjusting knob behind the guide, either left or right. This will move the key guide in or out. Do this until the cutter just grazes the top of the right service bar when the left service bar is resting against the key guide. Turn the cutter by hand; adjust to the high spot of the cutter.
3. Tighten the key guide Allen screw.

NOTE: This adjustment must be made if the cutter is replaced or whenever a test key fails to work, indicating that the cutter may have worn down somewhat, resulting in cuts that are too shallow.

ADJUSTING FOR PROPER LATERAL DISTANCE (SPACING)

Key cutting accuracy also depends upon the spacing of the key and blank key to be the same as the distance between the key guide and cutter. To assure that the lateral distance adjustment is correct, refer to Figures 2

and 3 and proceed as follows:

1. Insert the service bars into the vise jaws making sure that each service bar is butting against the edge of each vise jaw. This is critical!

ADJUSTMENTS

SPACING ADJUSTMENT (Continued):

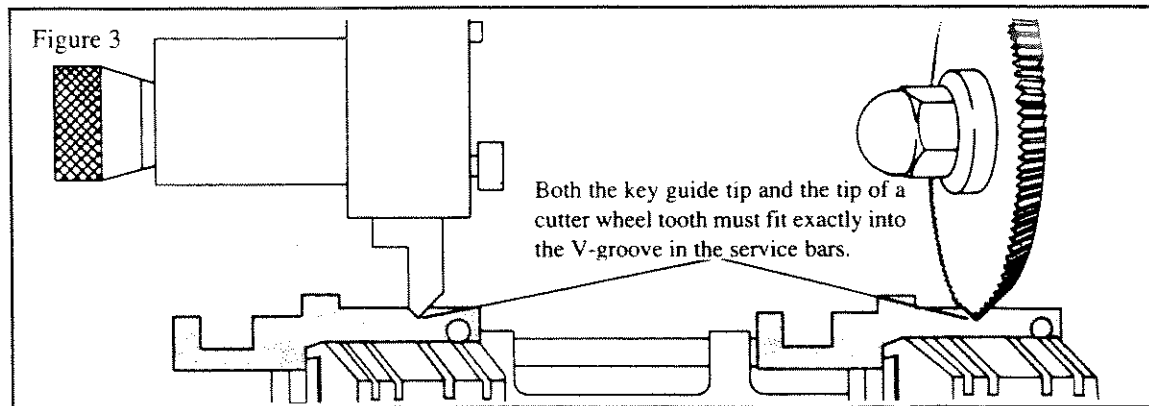
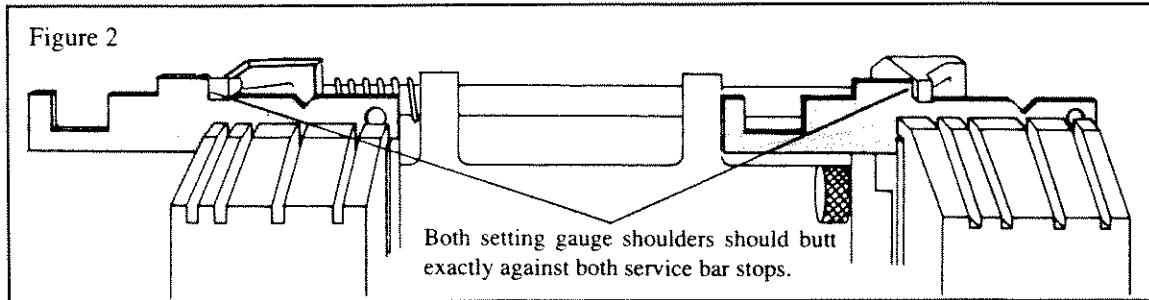

2. Rotate the key setting gauge up and make certain that both setting gauge shoulders rest exactly against the service bar stops as shown in Figure 2.

If there is a discrepancy, loosen the right setting gauge Allen screw and adjust so that both gauge shoulders rest exactly against both service bar stops.

3. Lift the carriage to the key guide and cutter. Insert key guide and cutter into the V shaped grooves in the service bars as shown in Figure 3. Both the key guide and the tip of a cutter wheel tooth must fit **exactly** into

their V grooves or the setting will not be accurate (make certain that you do not seat the space between two cutter teeth into the V groove).

4. If the guide and cutter do not seat exactly into each of the V grooves, the distance between the cutter and guide must be altered. Loosen the Allen screw in the key guide assembly and turn the micrometer adjusting knob fore or aft. This action will shift the position of the key guide assembly to the left or right. Continue until the key guide and the cutter both drop into the V notches of the service bars.

ALIGNING KEYS WITH SHOULDERS

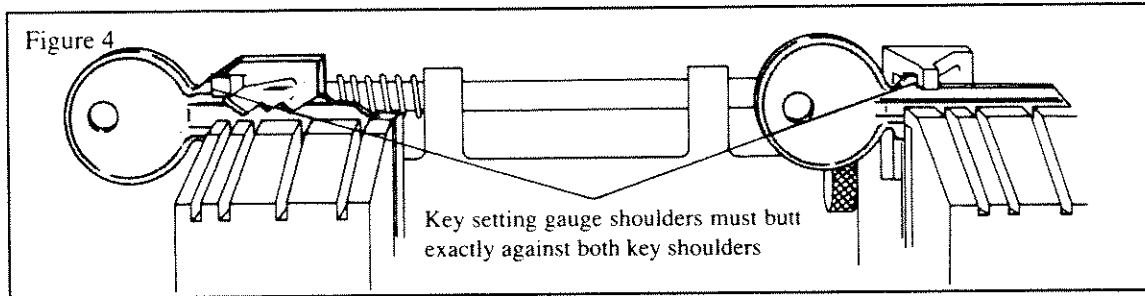

Insert the pattern key, left to right, into the left vise. Rotate the key setting gauge upward and set its left shoulder against the shoulder of the pattern key. Be sure the key is lying flat along the bottom of the vise. Secure the key by turning the clamp assembly clockwise.

Insert the key blank in the same manner, into the right vise, and secure. Make sure that the key setting gauge is exactly against **both** key shoulders. The key and key blank now are spaced the correct distance apart and are ready for cutting. See Figure 4.

ALIGNING KEYS WITHOUT SHOULDER (FORD AND BEST)

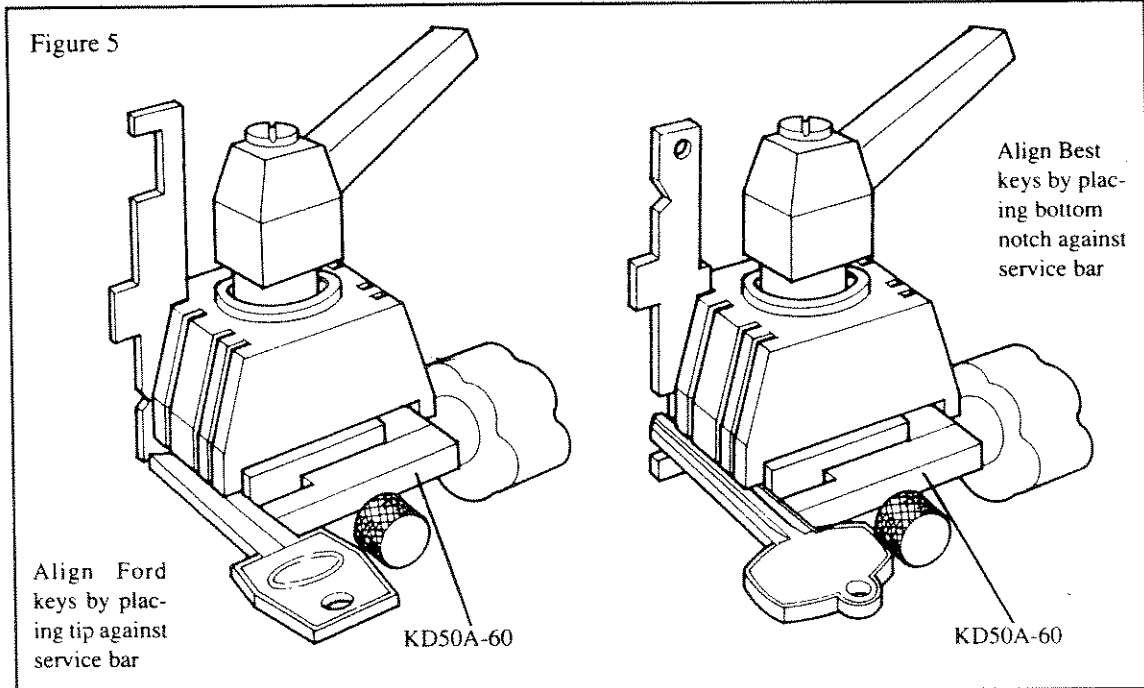

On keys without shoulders, the key setting gauge cannot be used. It is necessary to use the service bar to correctly position the key and the blank.

The vise jaws have a series of slots and any slot can be

used for the service bar. Also note the key head rest (KD50A-60), which prevents the key from tilting as the vise jaw is tightened. The key head rest can be moved to properly support the key. See Figure 5.

HOW TO ALIGN KEYS

ALIGNING NARROW BLADE CYLINDER KEYS

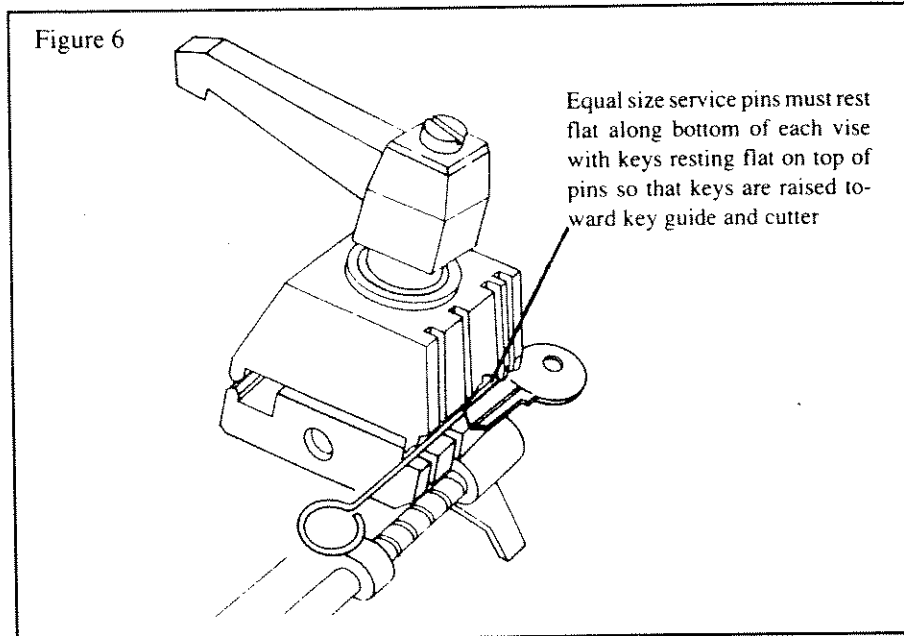

Some keys have a very narrow blade and therefore sit deep in the vise jaws with only part of the cuts showing above the vise. This makes it necessary to use the service pins to raise the key for proper cutting.

Insert an equal size pin under each key and blank on the bottom of the vise jaws. This will raise both the key and blank to allow the correct depth of cut to be made. See Figure 6. Do not cut into vise jaw!

ALIGNING DOUBLE SIDED CYLINDER KEYS

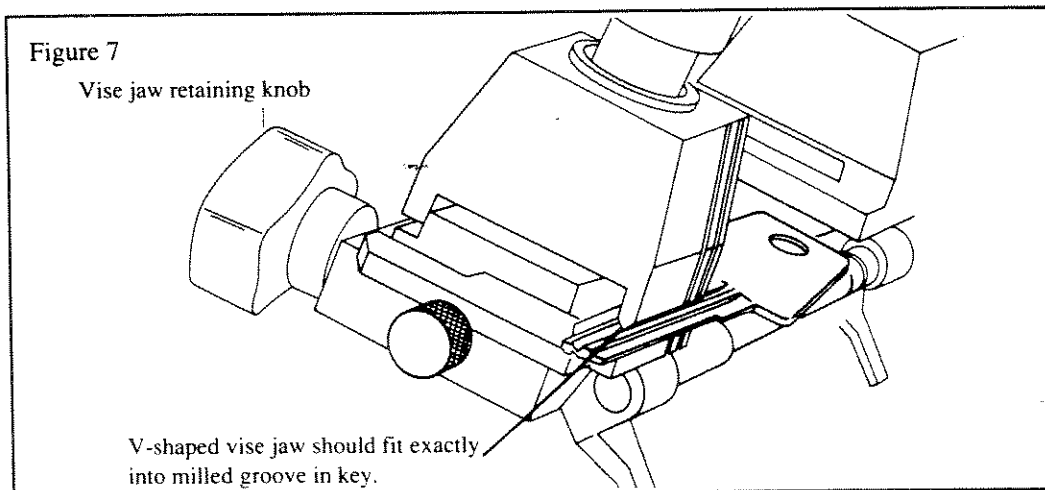

Before cutting this style of key, examine the key to see if there is a milled groove on either side. If so, then reverse the vise jaw and clamp the key using the V jaws. The key

will be held securely when only the top or bottom V jaw fits into a milled groove. When there is no V groove on either side of the key, then use the flat vise jaw.

ALIGNING DOUBLE SIDED CYLINDER KEYS (Continued):

If the cuts are not the same on both sides of the key, make the shallow cuts first so that, when you turn the key over to cut the second side, there will be enough metal to grip the key securely during the actual cutting. To reverse the vise jaw, loosen the retaining screws at the base of the

vise jaws. Raise, rotate and reseat both vise jaws and then retighten their retaining screws. Note the V shape of the jaws. Insert the key between the jaws, with a milling groove resting in the point of the V. This will hold the blank securely. Align for spacing and proceed cut.

ALIGNING CARRIAGE TO PREVENT VISE JAW DAMAGE

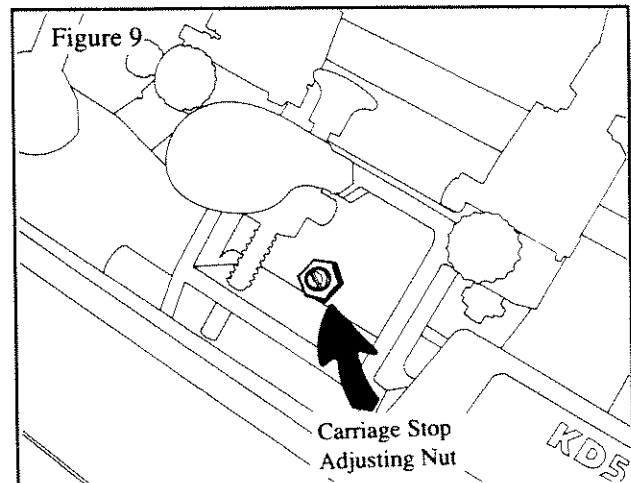
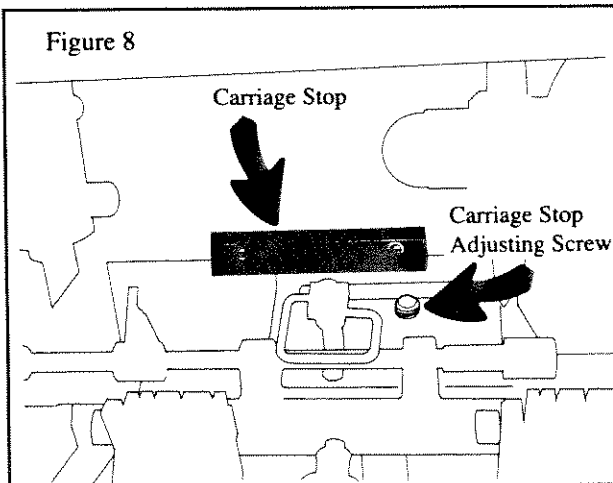

This machine is equipped with a carriage stop that prevents the carriage from moving all the way up to the cutter. When properly adjusted, it stops the cutter from grinding into the vise jaw. Such a condition could occur when reaching the tip of the cut key, and the carriage lever continues to move the carriage.

The carriage stop (Part No. KD50A-144) is a U-shaped channel secured to the housing by set screws. It's positioned to span the travel of the carriage during the cutting cycle; normally, this position does not change. In addition, there's a carriage stop adjusting screw that is installed in the carriage; this screw controls the distance between the cutter and the vise jaw. See Figure 8.

The carriage stop adjusting screw is set at the factory to

create a clearance of .005" between the cutter and the vise jaw. This distance is NOT critical and can be set without measuring instruments. Just loosen the lock nut and turn the screw in or out so the cutter does not touch the vise jaw. The machine should be off. When an ordinary business card can slide between the cutter and vise jaw, the adjustment is correct and the accuracy of key cutting will not be affected. CAUTION! Do not make this clearance too wide. Key cutting could be effected on some keys having deep cuts.

It's a good idea to check the clearance on a regular basis, especially when a large quantity of keys are cut. If the cutter is allowed to strike the vise jaw, the edges of the cutter will be dulled immediately, causing a reduction in the life of the cutter.

REPLACEMENTS

CUTTER, BELT OR KEY GUIDE CYLINDER

If the belts stretch, they will slip when the motor is in motion, thus reducing the power supplied to the cutter. This will be evident to the operator, since the cutter will slow down. A belt nut adjustment (See Figure 10) will give proper tension to the belt until it must be replaced. To reach the belt adjustment nut, open the top cover of the machine. Replace cover after adjustment is made.

There's no prescribed length of time that a cutter should last since this depends upon the usage to which it's subjected. Factors such as the length of time to cut a key, sound, appearance, and "feel", are some of the clues that will indicate when a cutter needs replacement. You should keep an extra cutter and key guide cylinder on hand for immediate replacement when needed.

To replace the cutter, just unscrew the cutter nut (note the left hand thread!) using the holding bar supplied to prevent the cutter spindle from turning (See Figure 11). Install the new one against the spindle shoulder. Replace washer and nut; tighten the nut securely.

One word about the key guide cylinder. This could become worn with heavy usage and should be replaced. Slight wear on the key guide cylinder can be compensated for by making a radial (tilting) adjustment. Loosen

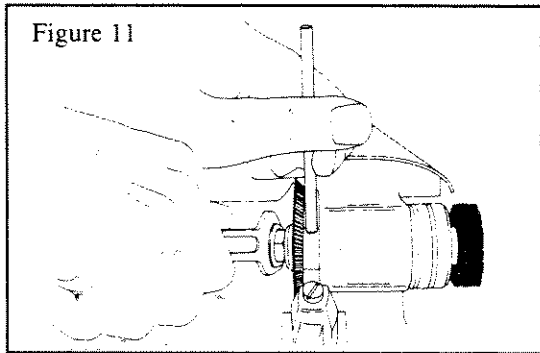
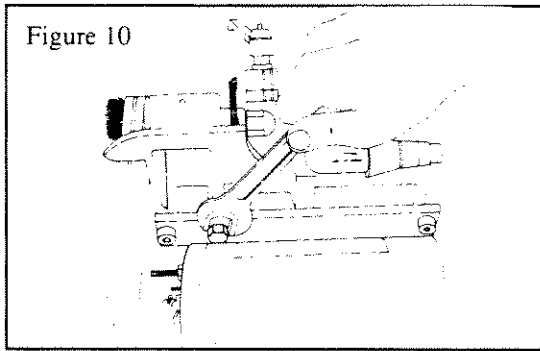

the Allen screw at the top of the key guide cylinder, then tilt the cylinder so that an unused portion of the cylinder edge makes contact with the V in the service bar (or cuts in the key). Retighten the Allen screw. Beyond that adjustment, a new cylinder is required. To replace the key guide cylinder, loosen the Allen screw on the right side of the cylinder and turn the rear micrometer until the cylinder drops out. Insert new cylinder, turn micrometer until tip of cylinder is properly adjusted for depth and retighten Allen screw.

SPACING AND DEPTH ADJUSTMENT

The practice of cutting duplicate keys requires that both the pattern key and the key blank be placed in the same relative position in the vise jaws. There are two alignments that are critical - spacing and depth. The key setting gauge controls the spacing; that is, it contacts the shoulder on both keys and sets them properly within the vise jaws. Do NOT attempt to bend or to alter the shape or position of the fingers of the key setting gauge. If the fingers are bent out of shape, they will not set the keys in proper relation to each other; this will cause an error in the spacings of the notches in the key.

key should just barely "kiss" the cutting wheel edge. If not, loosen the key guide Allen screw and adjust the rear micrometer knob, in or out as needed.

For best continually accurate key cutting, it's advisable to keep a "test" lock in your key cutting area. Every month or so, depending upon the quantity of keys you cut, make a duplicate of the original key for your test lock. Try the duplicate in the lock and look for any binding or hard turning of the key. If it works smoothly, your machine is maintaining its adjustment. If it binds, you should recheck your key cutting techniques and adjustments. We recommend that a high quality locking device, such as a Master pin tumbler padlock or a Schlage pin tumbler lockset, be used as the test lock.