

INSTRUCTION MANUAL

IMPORTANT! Read these instructions before you use your new 046 Key Machine.
Ensure that all safety recommendations are followed!
See page 3 for instructions.

PERFORMANCE *Series*

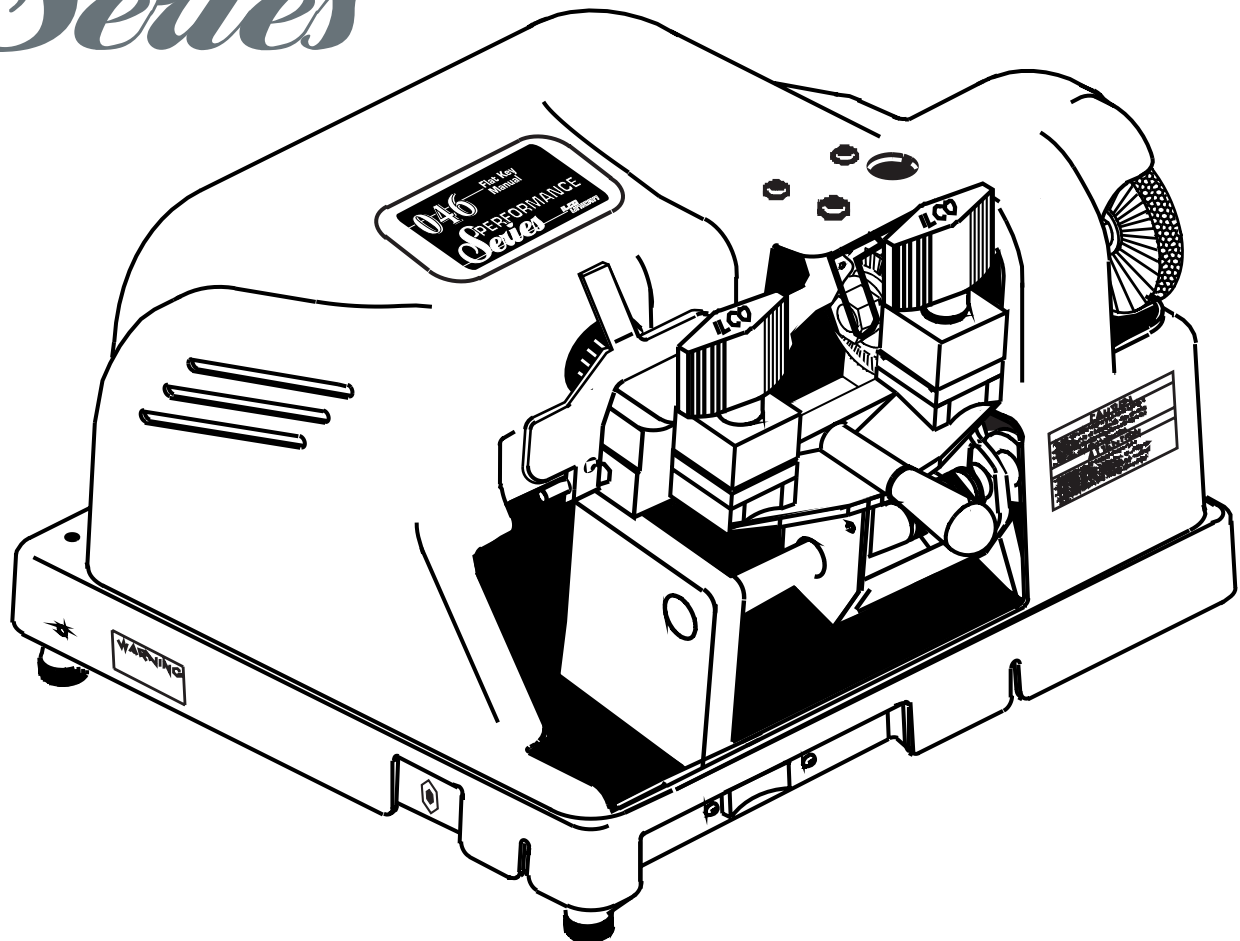

ILCO UNICAN

This manual applies specifically to the 046 Performance Series key machine. It properly identifies your model and assures you will receive correct parts, if and when you require replacement parts. Retain this manual in a safe place. If ownership of this machine is transferred, this service manual should accompany the machine.

When seeking service information about this machine, refer to Model No. 046 and the part number desired (see pages 6 to 8). Note that many parts are not interchangeable with other ILCO UNICAN machines.

CONTENTS

Warranty	2
Safety information	3
Introduction / unpacking	4
Operating parts (illustrated).....	5
Operating parts identification (names and part numbers) ..	5
Exploded view	6
Exploded view parts list / unpacking / test keys	8
How to duplicate keys	9
The cutting operation / replacing the cutter	12
Adjustments	13

ONE YEAR LIMITED WARRANTY

ILCO UNICAN warrants to the original buyer of any new model 046 machine that it will repair or replace, at its option, any part of any machine which proves, to the reasonable satisfaction of ILCO UNICAN, to have defects arising from the faulty manufacture of the machine or from defective material or components, during a period of one (1) year from the date of shipment of the machine by ILCO UNICAN, provided that the machine is returned by prepaid transport to ILCO UNICAN or to its authorized representative before the expiry of the warranty period together with a detailed description of the alleged defect(s). ILCO UNICAN may, at its discretion, elect to refund the purchase price allowable to the part affected, or to issue a credit if the price therefore remains unpaid.

ILCO UNICAN sells precision-made machines. The buyer assumes all risks, and ILCO UNICAN shall not be liable for any reason, if the machine has been subjected to improper installation, improper use, improper or inadequate maintenance, negligence, if any unauthorized modification or alteration is made to the machine, or in case of accident. For greater certainty, any machine not operated in accordance with ILCO UNICAN printed instructions or operated beyond its rated capacity shall not be covered by this or any other warranty.

Any and all warranties made by ILCO UNICAN on any machine, product, or component thereof shall be effective only if and for so long as the buyer complies with all payment obligations pursuant to the buyer's accepted and acknowledged order. Failure to meet such payment obligations shall void all warranties and not extend the period of time for which such machine, product or component thereof is warranted irrespective of whether or not payment is eventually made.

These warranties are in lieu of and not in addition to any other warranty of condition, expressed or implied, including without limitation merchantability, fitness for a particular purpose or latent defects. The buyer releases ILCO UNICAN from any liability for any reason other than a breach of its warranties hereunder.

The liability of ILCO UNICAN shall in no case, including negligence, exceed the purchase price of the defective machine, nor shall ILCO UNICAN be liable for any personal injuries, property damage or consequential damages.

Use only genuine ILCO UNICAN replacement parts on this machine!

Serial number : _____

WARNING – SAFETY NOTICE

IMPORTANT - Please read carefully before operating machine.

Safety begins with education, and continues with proper application. All personnel who operate your machine should read the supplied Operator's Manual for information on how to properly operate it. The likelihood of accidents and miscuts will be greatly reduced.

General safety

- Safety glasses must be worn to reduce the possibility of eye injury while operating or in the immediate vicinity of key cutting equipment.
- Always turn machine off before making adjustments or inserting or removing keys.
- Machine should be located in an area accessible only by authorized operators. Location must be such that customers and other personnel are not subject to potential injury from "flying chips".
- Do not defeat safety features built into your machine. Removal or modification of safety shields, cutter guards, and other safety devices should be strictly forbidden.
- At no time should the mechanically-driven parts of the machine be touched while it is in operation. The operator should take care to ensure that loose-fitting clothing, long hair, etc. are kept from the area of machine operation.
- Your machine has been specially designed and built for key cutting purposes only and should be operated according to the Operator's Manual. All other uses are strongly discouraged as potentially dangerous, and should not be attempted! Such use will immediately void the machine's warranty.
- Some states have specific age restriction concerning the operation of certain types of equipment. Check local and state ordinances for compliance.

Electrical safety

- (115 Volt models) Your machine is designed to operate using 120 Volt A. C. 60 Hz. electrical current. It is supplied with a three-prong power plug which should be used with a properly grounded three-prong outlet only. Do not defeat the safety purpose of the plug by modifying or using with non-grounded outlets!
- To reduce risk of fire or electrical shock, do not expose or operate machine in damp or wet locations.
- Electrical problems should be referred to qualified repair technicians. If the machine is under warranty, contact ILCO UNICAN at the address printed on the cover. (ILCO UNICAN also offers repair service for out-of-warranty machines. Contact ILCO UNICAN for details.)
- Always unplug the machine before removing the hood or changing the cutter wheel.

Grounding instructions

- In the event of a malfunction or breakdown, grounding provides a path of least resistance for electric current to reduce the risk of electric shock. This machine is equipped with an electric cord that has an equipment-grounding conductor and a grounding plug. The plug must be plugged into a machine outlet that is properly installed and grounded in accordance with all local codes and ordinances.
- Do not modify the plug provided - if it will not fit the outlet, have the proper outlet installed by a qualified electrician.
- Improper connection of the equipment grounding conductor can result in a risk of electric shock. The conductor with insulation that has a green outer surface (with or without yellow stripes) is the equipment-grounding conductor. If repair or replacement of the electric cord or plug is necessary, do not connect the equipment grounding conductor to a live terminal.
- Check with a qualified electrician or service personnel if the grounding instructions are not completely understood, or if in doubt as to whether the machine is properly grounded.
- Use only 3-wire extension cords that have 3-prong grounding plugs and 3-pole receptacles that accept the machine's plug.
- Repair or replace damaged or worn cords immediately.

INTRODUCTION / UNPACKING

Congratulations!

You've purchased a superior key cutting machine.

The Model 046 manual Performance Series key machine you've just purchased incorporates the latest improvements in design for key duplicating machines of its type.

This machine features exclusive four-way vise jaws designed to accommodate flat type keys (safe deposit, locker, etc.) without the need for adapters.

Even corrugated flat keys can be duplicated with ease; the four-way jaws include stations ideally suited to gripping these keys and is capable of gripping them in the groove or milling for enhanced clamping performance when necessary.

Accurate, easy to operate and maintain, the model 046 delivers excellent performance at an economical price!

Unpacking instructions

Your 046 key machine has been shipped to you in a sturdy, specially cushioned container to prevent the possibility of damage during handling and shipment. Once the machine is removed from the carton, it should be set up on a level workbench and wiped free of all rustproofing

oil. The machine is adjusted at the factory and test keys have been cut on it, but it is recommended that you check the adjustments to make sure they have not slipped or shifted during transit (see page 13 "Adjusting for depth of cut").

Safety

The 046 has been engineered to duplicate flat (safe deposit, etc.) keys. It is not intended or designed for any other purpose. The machine operator assumes all liability when using this machine in a manner inconsistent with its stated design purpose. Refer to page 3 for complete safety information before operating the machine.

ILCO UNICAN **strongly recommends** the use of protective eye glasses or goggles when operating this ma-

chine, or when in the vicinity of the machine while it is being operated. Protective eye wear prevents injuries! The machine should be turned off before loading or unloading keys.

When the key machine is operating, be careful not to contact the vise jaw or carriage against the cutting wheel as this will cause damage to the cutter, jaw, or carriage.

CAUTION! DO NOT DESTROY OR DISCARD THIS SPECIAL SHIPPING CARTON. STORE IT CAREFULLY IN A SAFE PLACE. THIS CARTON SHOULD BE USED WHENEVER THE MACHINE IS MOVED OR SHIPPED.

OPERATING PARTS

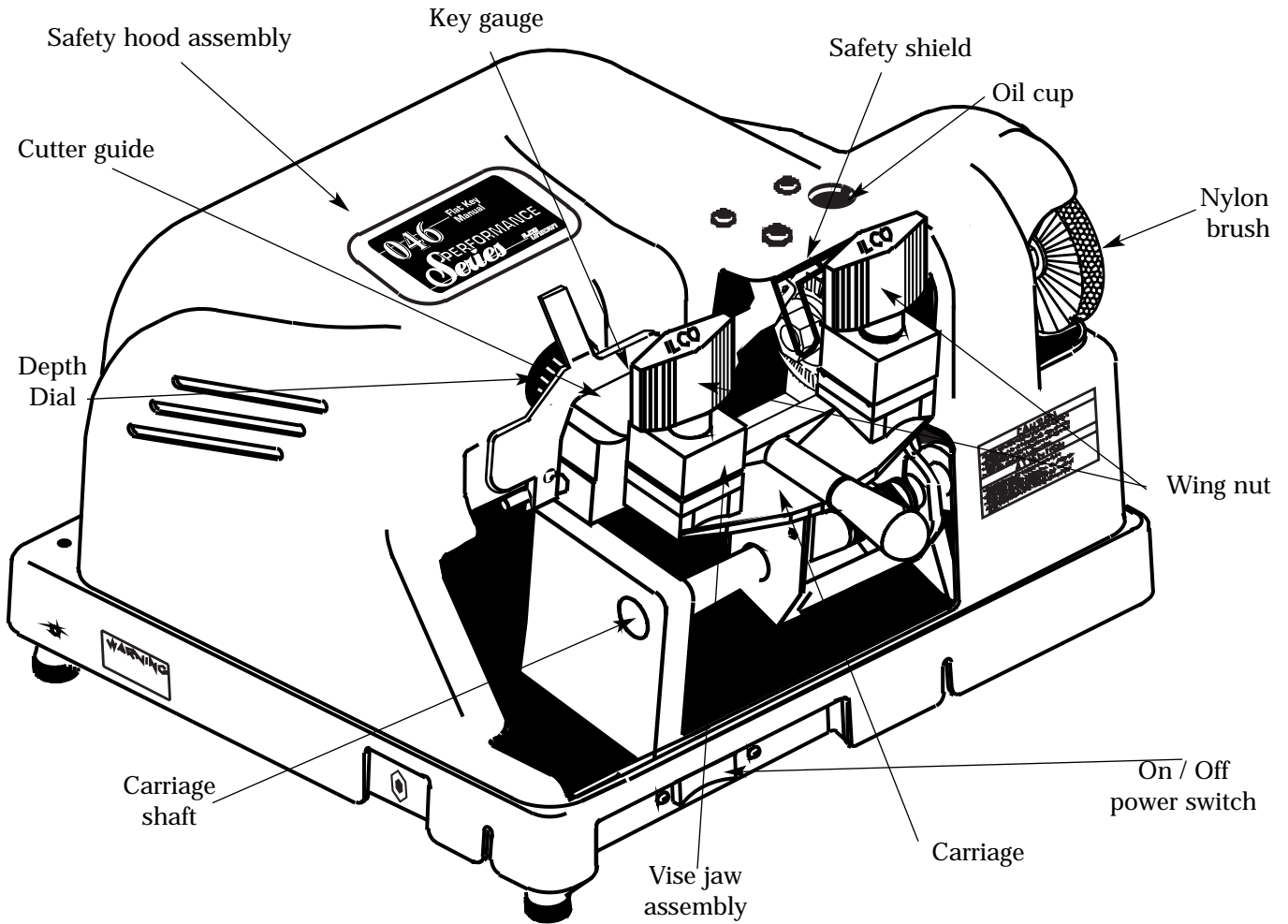

Operating parts identification

Part no.	Identification
024B-1	Carriage
025-3X	Vise jaw assembly
025-8	Wing nut
045-23	Carriage shaft
P-SMS45	P-SMS45 cutter
814-00-51	Nylon brush
046-49	Cutter guide (stylus)
045-55A	Adjusting screw
040-56	Key gauge
025-62A	On/Off switch
025-82	Oil cup
046-86X	Safety hood assembly
045-87	Safety shield

EXPLODED VIEW

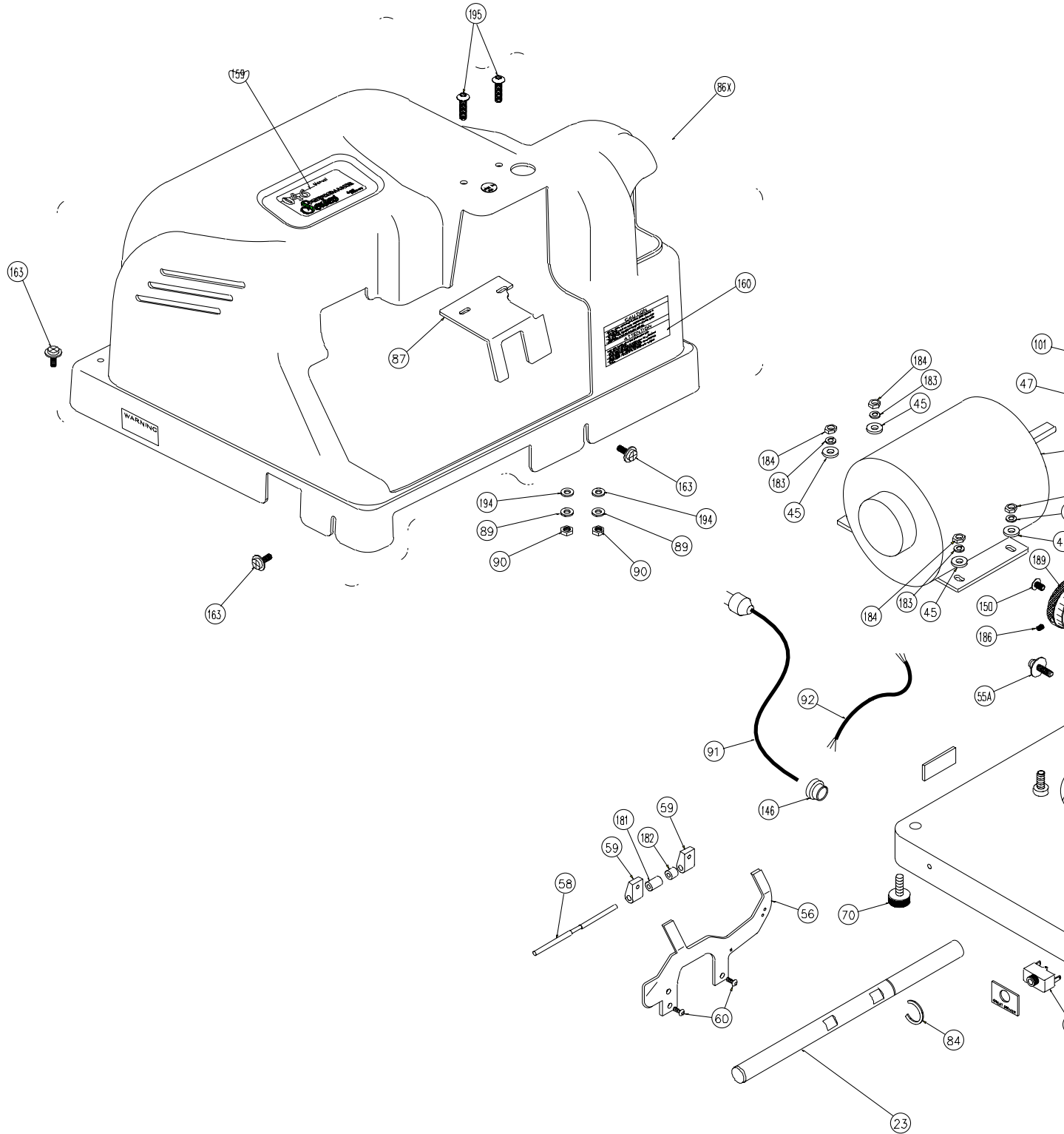

EXPLODED VIEW

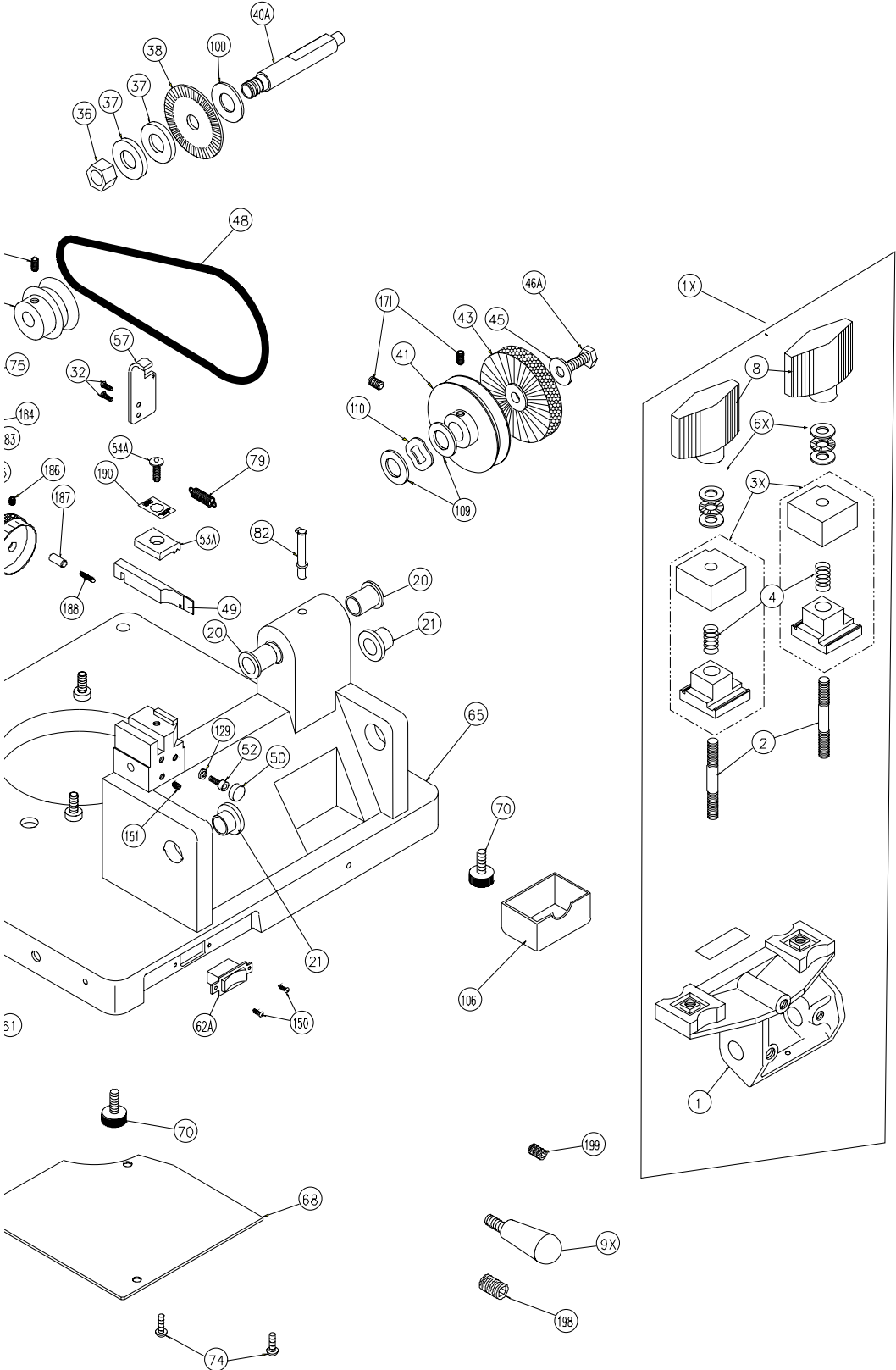

EXPLODED VIEW PARTS LIST

Refer to pages 6-7 for illustration

Ref.	Part no.	Description	Ref.	Part no.	Description
1	024B-1	Carriage	75	040-75	Motor, ¼hp,115V
1X	024B-1X	Carriage assembly	79	024B-79	Key gauge spring
2	025-2	Carriage stud	82	025-82	Oil cup
3X	025-3X	Vise jaw assembly	84	024B-84	Clip
4	025-4	Vise jaw spring	86X	046-86X	Safety hood assembly
6X	025-6X	Thrust bearing set	87	045-87	Safety shield
8	025-8	Wing nut	89	046-89	#10 Lockwasher
9X	040-9X	Carriage handle	90	025-90	Nut, #10-32
20	025-20	Cutter shaft bushing	91	024B-91	Power cord
21	025-21	Carriage shaft bushing	92	024B-92	3 wire motor cable
23	045-23	Carriage shaft	101	025-101	Motor pulley set screw
32	024B-32	Button head. screw, 10-24 x ¾"	106	040-106	Chip tray
36	025-36	Cutter nut, N-4	109	025-109	Bearing washer
37	025-37	Cutter spacer	110	025-110	Wave washer
38	P-SMS45	P-SMS45 cutter	129	040-129	Locking nut (8-32)
40A	025-40A	Cutter shaft	146	040-146	Power cord strain relief
41	025-41	Cutter shaft pulley	150	040-150	Switch screw (6-32 x 1/4")
43	814-00-51	Nylon brush	151	040-151	Set screw (8-32 x 3/8")
45	024-45	Brush bolt washer, 5/16"	160	025-160	Caution label
46A	025-46A	Hex head screw, 5/16-18 x ¼"	163	045-163	Hood Screw
47	025-47	Motor pulley 2" - 3L	171	025-171	Cutter pulley set screw, ¾" -18
48	025-48	V-Belt, 3L-180	181	024B-181	Key Gauge Spacer - Left
49	046-49	Cutter guide (stylus)	182	024B-182	Key Gauge Spacer - Right
50	040-50	Carriage stop	183	040-183	1/4-20 Lockwasher
51	026-51	Cutter shaft thrust washer (thin)	184	040-184	1/4-20 Hex Nut
52	040-52	Socket hd. screw 8-32 x 1-1/2"	186	045-186	6-32 x 3/8" set screw
53	045-53A	Cutter guide binding washer	187	045-187	dowel
54	045-54	Cutter guide binding screw	188	045-188	dowel spring
55A	045-55A	Adjusting screw	189	045-189	Adjustment dial
56	040-56	Key gauge	190	045-190	Cutter guide label
57	024B-57	Key gauge bracket	194	045-194	#10 flat washer
58	024B-58	Key gauge dowel pin	195	045-195	10-32 x 1/2" Button hd. screw
59	025-59	Key gauge housing	198	045-198	7/16-14 x 3/4" set screw
60	025-60	Cap screw, 8-32 x ½"	199	045-199	1/2-20 x 1/2" set screw
61	025-61	Circuit Breaker, ETA 1658	IM	046-IM	Instruction manual
62A	025-62A	On/Off switch	NS	025-240	220V ¼HP motor
65	045-65	Machined base			
68	040-68	Electrical cover			
70	040-70	Rubber mount			
74	040-74	Truss head screw, 8-32			

Unpacking

The 046 key machine is shipped completely assembled except for the carriage handle. Upon unpacking the machine, locate the carriage handle and thread it into the carriage.

Test keys

A series of cut keys are supplied with your machine. These keys were cut on your machine and represent the result of our quality inspectors' work before approving your machine for shipment. The keys are reproductions of factory dimensioned pattern keys and are accurate to .002" or less. You can conduct periodic testing of your machine's accuracy by duplicating a key and then using a key micrometer or caliper to compare the actual depth of the cuts on both the duplicate and the pattern key will allow you to see if your machine is cutting too deep or too shallow, thus indicating that an adjustment of the cutter guide is necessary.

Proper key cutting techniques

Even though your 046 key machine is designed to make key cutting fast, efficient and accurate, operator skill is important. The actual mechanics of placing keys within the vise jaws is simple to learn, but there are some basics that must be followed. A properly adjusted key machine used by someone who ignores good key cutting techniques will NOT produce a good key. The way a person clamps a key into the vise jaws is critical to the accuracy of the duplicated key.

Remember - the real purpose of a duplicate key is to operate the lock for which it was intended. If customers return keys, you should reexamine your cutting techniques and adjustment of the machine.

Here are some important operating tips:

1. Vise jaws - clean them regularly so that no metal chips lie under the keys. **It is essential that both keys lie flat across the entire width of each vise jaw. Neither key should be tilted.**
2. Do NOT use pliers or other tools to tighten the vise jaws. Firm hand pressure is sufficient.
3. Keep the carriage shaft free of metal chips. A thin film of oil can be applied to it. The carriage should be free to move without binding.
4. NEVER touch the shoulder of a key to the side of the cutter guide. This will cause the shoulder of the key blank to touch the side of the cutting wheel. When this happens, some of the metal will be cut away from the shoulder of the key blank. If the resulting duplicated key is duplicated two, three, four times over, an error will accumulate and cause a non-operating key. Do not grind away the shoulder.
5. Don't run the cutter into the vise jaw; this will dull the cutter, and reduce cutter efficiency.
6. Keep the cutter clean. Don't let any foreign objects or instruments blunt it. This cutter is a precise cutting tool and should be handled with care.
7. Lubrication of moving parts is important. An oil cup is provided to keep the cutter shaft bearings well lubricated. (5-7 drops of 3-in-1 or lightweight spindle oil in the oil cup is sufficient.) The carriage spindle should be lubricated with a thin film of oil and wiped free of chip build up. The lubrication procedures should be performed every 2-3 weeks depending on usage. The motor requires lubrication on an annual basis. See motor label for details.

HOW TO DUPLICATE KEYS

General key duplication procedures

WARNING: Do not install or remove keys unless the off/on switch is in the OFF position! Always wear eye protection when operating this machine!

There are four procedures that the machine operator performs to insure proper duplication of a key:

1. Selection of the proper key blank. Compare the head, length, and key blank's cross section (width, angle, and location of grooves) with the key to be duplicated to assure that a proper match has been made.
2. Ensuring both four-way vise jaws have been placed in the proper position for the type of key to be duplicated. See "Using the four-way vise jaws" section of this manual.
3. Proper alignment of the pattern key and blank key within the vise jaws. See "Aligning keys in the vise jaws".
4. Actual duplication of the pattern key; which can be properly accomplished only after the previous steps are performed.

Using the four-way vise jaws

Your 046 is equipped with the ILCO UNICAN versatile Four-way, Super Jaw 2 vise jaws. They feature four unique clamping surfaces to securely grip virtually any typical flat style key (see Fig. 1).

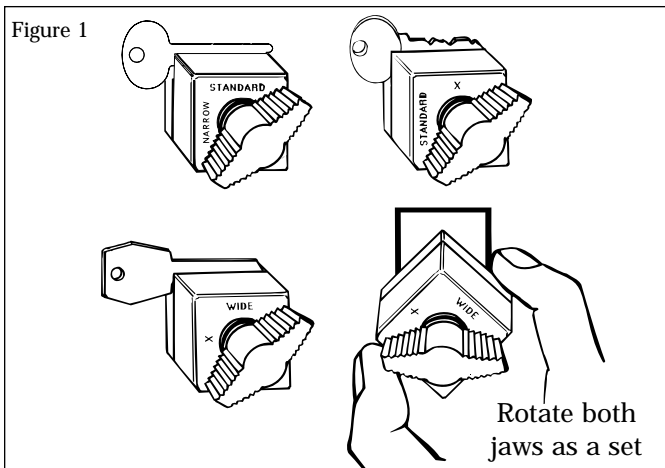

Using the four-way vise jaws (cont.)

To obtain the best gripping action possible, it is necessary to assure that the proper vise jaw position is selected for each key you duplicate. The vise positions are explained below and proper usage shown in figure 2.

Standard - for holding most typical flat keys, including many common safe deposit, locker and corrugated pad-lock types.

Narrow - for holding narrow flat keys as well as those with very deep cuts.

Wide - for holding wide flat keys, typically those 1/2" or more in width.

X - sometimes quite useful for holding corrugated flat keys and those with milled grooves. Generally, if such keys cannot be securely gripped using another vise position this position may provide improved clamping performance.

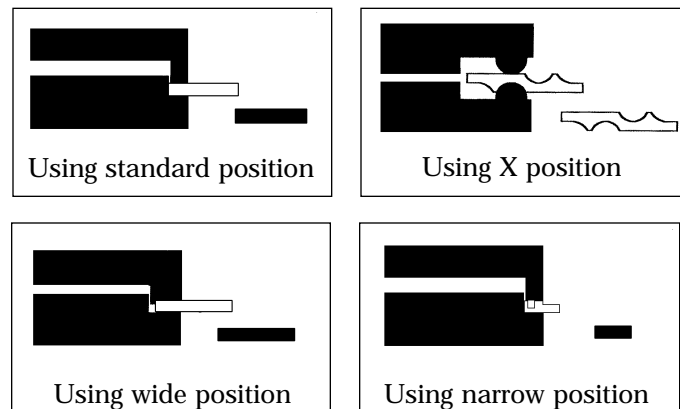

To reposition the vise jaws, as from Standard to Wide, first loosen the wing nuts. Then lift upward on the top and bottom of each vise jaw as a complete unit to raise them above their seat in the carriage. Rotate the jaws until the chosen vise position is facing toward the rear of the machine and lower the jaws back into contact with the carriage. Both left and right vise jaws should be rotated to the same position.

Aligning keys in the vise jaws Keys with shoulders

WARNING: Do not install or remove keys unless the off/on switch is in the off position.

Both the pattern key and the key blank must be properly aligned and securely clamped in the vise jaws. To do this, slide the machine's carriage assembly towards the right and position the appropriate key blank in the carriage's RIGHT vise jaw with the head of the blank pointing to the left.

Ensure that the shoulder of the key blank is located approximately $\frac{1}{8}$ " to the left of the vise jaw's left edge. Holding the key blank firmly and level against the jaw, tighten the wing nut. Position the pattern key in the carriage's LEFT vise jaw in a similar manner only this time allowing a $\frac{1}{4}$ " gap between the shoulder of the key and the edge of the vise jaw.

Next lower the key gauge and position the carriage so that the left edge of the gauge's RIGHT prong contacts the edge of the key blank's shoulder (see Figure 3). Loosen the wing nut securing the pattern key and reposition the key so that its shoulder is in contact with the

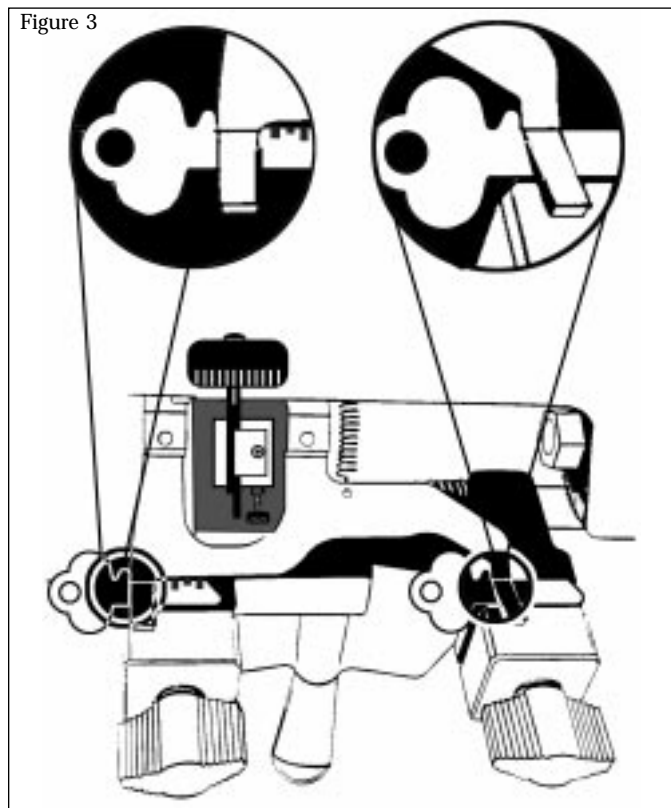

left edge of the LEFT prong of the key gauge.

Check to ensure that the pattern key and blank key's shoulders are snug against the key gauge and both keys are positioned level (not tilted) in the vise jaws. Retighten the wing nut.

Aligning keys in the vise jaws Keys without shoulders

Most flat keys do not have a conventional shoulder. With such keys, the aligning point is generally the vertical surface closest to the tip of the key (see Figure 4 - End Stop).

To align these keys, clamp the blank key in the RIGHT vise jaw and move the machine carriage to the left. Lower the key gauge and position the carriage so that the key gauge prong contacts the vertical surface indicated in Figure 4. Insert and align the pattern key in the left vise jaw in the same manner.

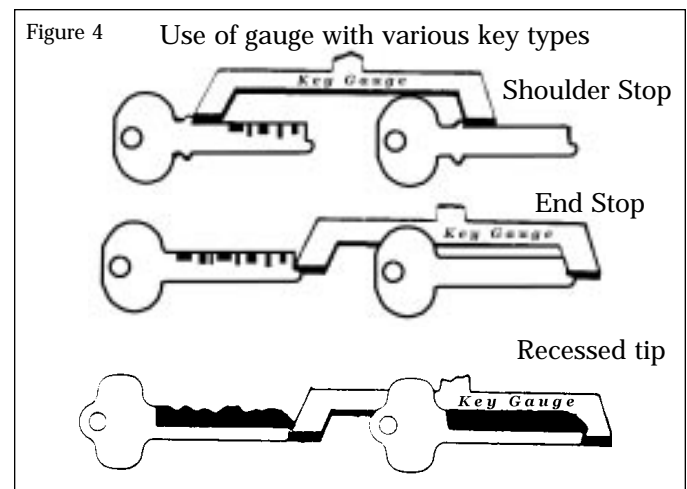

It is important that the key gauge prongs are in contact with both keys at the same time.

THE CUTTING OPERATION / REPLACING THE CUTTER

General Operating Sequence

WARNING: Do not install or remove keys unless the off/on switch is in the off position.

1. Rotate both vise jaws to the station suitable for the key being duplicated.
2. Insert the blank key and pattern key into the vise jaws using the appropriate method described under "Aligning Keys in the Vise Jaws". Be sure that both keys are laying level in the vise jaws and are not tilted.
3. Lower the key gauge to align the keys using an appropriate method as described under "Aligning Keys ..." found in the previous section (see page 10).
4. After the keys are aligned, return the gauge to its "up" position.
5. Press the off/on switch to the "on" position.
6. Lift the carriage with both hands (see Figure 5).
7. Move the carriage to line up the cutter guide with the shoulder of the pattern key, then shift slightly away from the shoulder. Do not permit the cutter to touch the shoulder of the key blank.
8. Press in on the carriage, while guiding it to the left. Carefully trace the cuts of the pattern key with the cutter guide. The cutter will make a corresponding cut in the key blank. When the cut closest to the tip of the pattern key has been traced, retrace the cuts by guiding the carriage to the right. This will clear away any metal not removed during the initial pass over the key blank.
9. Press the off/on switch to the "off" position. Remove the blank key. Press the switch to the "on" position and remove any burrs that remain by contacting the key lightly against the deburring brush. Return the switch to the "off" position.
10. Operating Tips - When duplicating a key, avoid an irregular jerking motion in the movement of the carriage. Acquire a smooth steady motion, using both hands on the carriage to guide it. Apply the same degree of pressure each time a key is duplicated. Excessive pressure may cause "over-cutting". It is sometimes best to practice on a few keys until the operator learns to impart a steady, uniform pressure to the carriage.

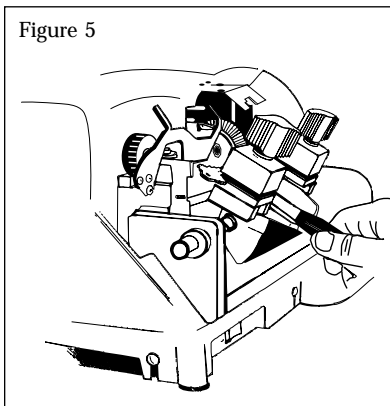

Replacing the Cutter

The P-45SMS cutter used on this machine is $\frac{2}{4}$ " in diameter, .045" thick and has a $\frac{1}{2}$ " hole. It's a side milling slotter, made out of high speed steel. No warranty is placed on the cutter, operators should treat it with care and avoid harsh usage. Do not force the carriage up, causing the key blank to bang into the cutter, and do not apply heavy pressure when cutting. Also, do not let the cutter run into the vise jaw; this will dull the cutter quickly.

As with any metal cutting instrument, the P-45SMS will dull with usage. There are three ways to tell when a cutter is dull and requires replacing:

1. Time - a dull cutter takes longer to make the cuts.
2. Sound - a dull cutter will emit a shrill sound as it runs across the key blank.
3. Burrs - a dull cutter will not cut away the metal but will roll it away. When this occurs, there will be a buildup of metal burrs on the underside of the key. If this buildup is heavy, the cutter is dull. A sharp cutter leaves little or no burrs.

To replace the cutter, use two wrenches, one $\frac{3}{4}$ " wrench for the cutter nut and one $\frac{1}{2}$ " wrench for the cutter shaft. Set the two wrenches in position and loosen the cutter nut. Note that the cutter nut has a reverse thread and turns downward to loosen. Remove the spacer washers and the dull cutter. Install the new cutter, the washers, and the nut.

Adjusting for depth of cut

To ensure safety, UNPLUG machine from its power source before adjusting for depth of cut. It's imperative that the key guide and the cutter be in the same plane, that is, aligned to each other. If the cutter guide protrudes further than the cutter, the resulting cuts in a key blank will be too shallow and the duplicate key will not work. Likewise, if the cutter guide is behind the cutter, the cuts in the key will be too deep (see Fig. 6).

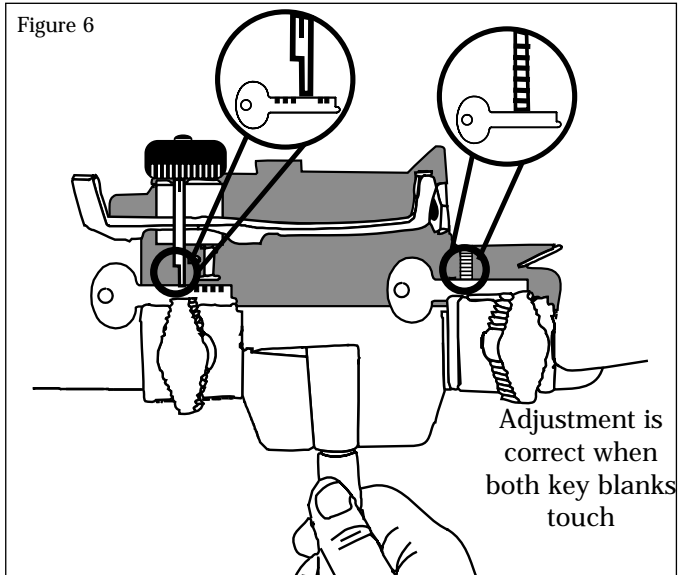

To check the depth adjustment, insert two identical key blanks into the vise jaws, setting them flat in each vise. (It is not necessary to align the blanks.) Then, raise the carriage, positioning the left blank against the cutter guide and the right blank against the cutter. Next, turn the machine pulley by hand and note the right key blank. The cutter should just barely graze the key blank when the adjustment is correct.

No cutter is perfectly round so make one complete rotation of the cutter before changing adjustment. There will

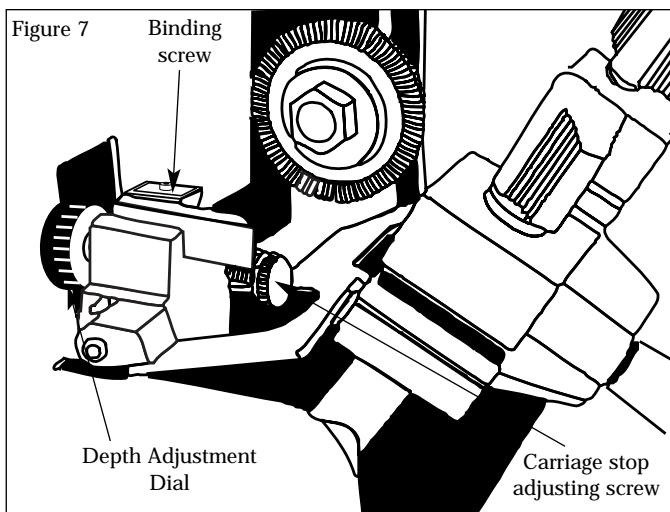

be a high point on the cutter; the adjustment should be made to the high point. If the cutter does not touch the key blank after one rotation, proceed to change the adjustment.

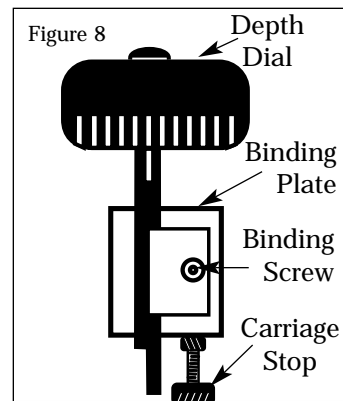

To adjust the cutter guide, loosen the binding screw on top of the cutter guide **slightly**. (see Fig. 7 & 8). Once you have loosened this screw, the depth adjustment dial can be rotated to the left (to decrease depth of cut) or to the right (to increase depth of cut). Again, proper adjustment will be achieved when the cutter

just **barely grazes** the key blank before it while the cutter guide is in contact with the other key blank. Retighten the binding screw once the calibration process is completed. Recheck after tightening to assure that adjustment did not shift.

Each calibration mark on the depth adjustment dial is equivalent to approx. .0015" (1 1/2 thousandths of an inch). As you can see, this system can allow for very precise adjustment of your new key machine. In fact, if you have a key micrometer or dial caliper available, you can adjust your machine with "factory accuracy". To do this, you would simply duplicate a key and measure cuts on both the "pattern key" and the duplicate key for comparison. This would show any deviation that existed and whether the duplicate cuts were too deep or too shallow and by how much. With this information, you can use the depth adjustment dial on your machine to calibrate your machine for best possible accuracy. This is very important as many locks are designed with close fit tolerances and the keys you duplicate are often themselves copies; functional but just barely so. The more accurate your key machine is adjusted, the closer your duplicates will match their originals, resulting in fewer non-functional miscuts!

It is very important to understand that adjusting your machine is not a "one time" procedure. As the cutter on your machine wears down, the machine must be adjusted to compensate. It is good shop practice to **check** your machines' depth adjustment every 2-4 weeks, based upon your store's key cutting volume and readjust as necessary. You will find that re-calibration is seldom needed, but by checking and correcting **BEFORE** customers begin returning miscut keys, you will create a reputation for your store as a "good place" to have keys duplicated.

ADJUSTMENTS

Adjusting for spacing

There is no adjustment for spacing. However, if a key gauge assembly is ever replaced, the key gauge must be fitted to the machine after it has been installed. To do this, first install a pattern key and key blank and align these against the cutter guide and cutter. Then lower the key gauge and file the appropriate finger of the gauge to allow contact with the shoulder of both keys.

Adjust the Carriage Stop

The purpose of the carriage stop is to prevent the cutter from hitting into the right vise jaw. The stop is a nut and bolt and is adjustable. To check the adjustment, raise carriage (without keys in vise jaws) and rotate the cutter by hand. The cutter should not contact the vise jaw. When the carriage stop is properly adjusted, there should be a space of .008" between the vise jaw and the cutter (this is about the thickness of an ordinary business card). Do not allow a greater distance since this may affect the depth of cut.

Cleaning

Your machine should be kept clean of all filings and dust. The most critical areas are the carriage jaws and shafts. A one inch paint brush is ideal to brush these areas of the machine. The shafts should be wiped periodically with a lightly oiled cloth. We suggest brushing the jaws often as even a single filing can alter the accuracy of the machine.

Lubrication Intervals

Lubricating of moving parts is important. An oil cup is provided to keep the cutter shaft bearings well lubricated (5-7 drops of 3-in-1 or lightweight spindle oil in the oil cup is sufficient.) The carriage spindle should be lubricated with a thin film of oil and wiped free of chip build up. The lubrication procedures should be performed every 2-3 weeks depending on usage. The motor requires lubrication on an annual basis. See motor label for details.

ILCO UNICAN

USA

ILCO UNICAN CORP.

400 Jeffreys Rd., Rocky Mount, NC 27802-2627

Tel.: (252) 446-3321 • (252) 446-4702

Canada and international

ILCO UNICAN INC.

7301 Decarie Blvd., Montreal, Quebec H4P 2G7

Tel.: (514) 735-5411 • (514) 735-4704

Export Fax: (514) 735-1393