

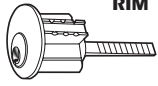



Trim & Function

Narrow Stile Rim Exit Device

ANSI/BHMA Functions:

01	02	03	08	09	11	12	14
EXIT ONLY - NO TRIM	PULL ONLY WHEN DOGGED FIXED PULLS BY OTHERS	KEY RETRACTS LATCHBOLT NL FIXED PULLS BY OTHERS	KEY LOCKS LEVER	KEY LOCKS LEVER NL	KEY LOCKS THUMBTURN	KEY LOCKS THUMBTURN NL	PASSAGE SET
CYLINDER TYPE							
N/A	N/A	 RIM	 MORTISE	 MORTISE	 MORTISE	 MORTISE	N/A

NL – Night Latch

Clutch Lever Entry Trim

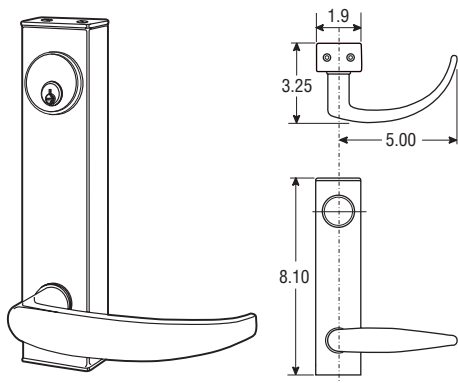

Modern Model 3081

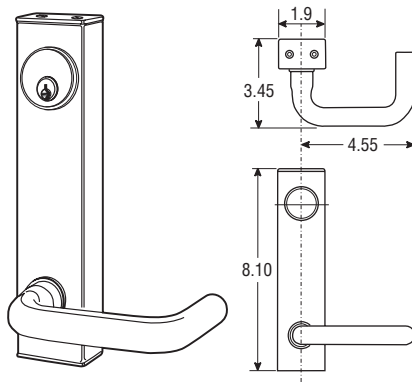

Tubular Model 3082

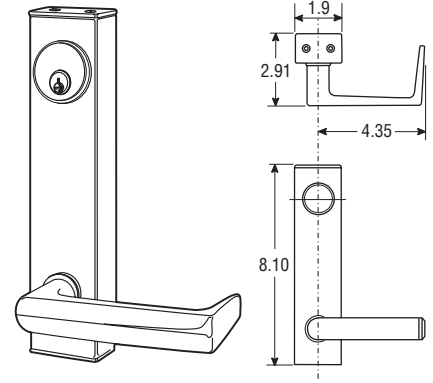

Traditional Model 3083

Thumbturn

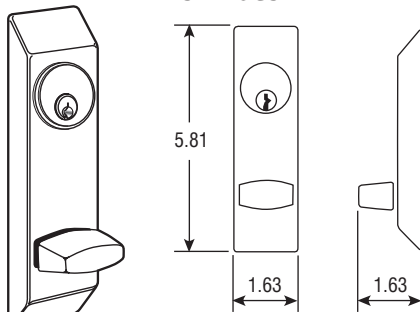

Model 8066

Mortise Cylinder

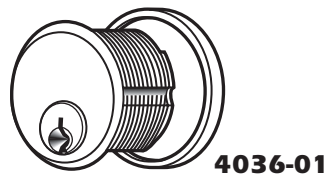

4036-01

Standard diameter five-pin unit with MS® cam, suitable for use with Entry Trim on Rim exit devices. All brass construction with front "scalp" available in finishes 628, 313 and 335. Available in quantity all keyed different (KD), in pairs (KA2) or fifty alike (KA50). Any other make standard Mortise cylinder with MS® cam can be used to "key in" with existing systems.

Rim Cylinder

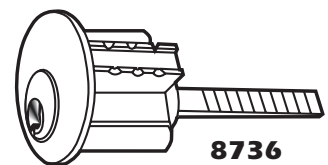

8736

Standard five-pin unit with spindle to suit Rim exit devices. All brass with same choices of keying as Mortise cylinder. Available in finishes 628, 313 or 335. Any other make standard Rim cylinder can be used to key in with existing systems. Note that if entry trim is specified for cylinder use, the cylinder must be Mortise type, regardless of exit device.