

▼ **Backset**

1-3/16" (1.25 including faceplate).

▼ **Case**

1/2" x 4 x 1-19/32" deep. Stainless steel. Bolt is laminated stainless steel.*

▼ **Faceplate**

5/8" x 4-1/2" with radiused ends. Stainless steel.*

* Also available in zinc-plated steel.

▼ **Operation**

45° rotation of turn or key throws or retracts bolt. Bolt is self-protecting; if door is shut while bolt is extended, it will retract, preventing damage or accidental lockout.

Wood Door Deadbolt

5017

ANSI/BHMA Type E8292 (Grade 2)

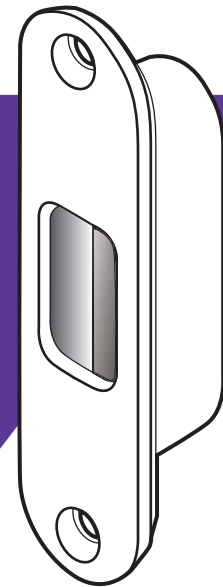
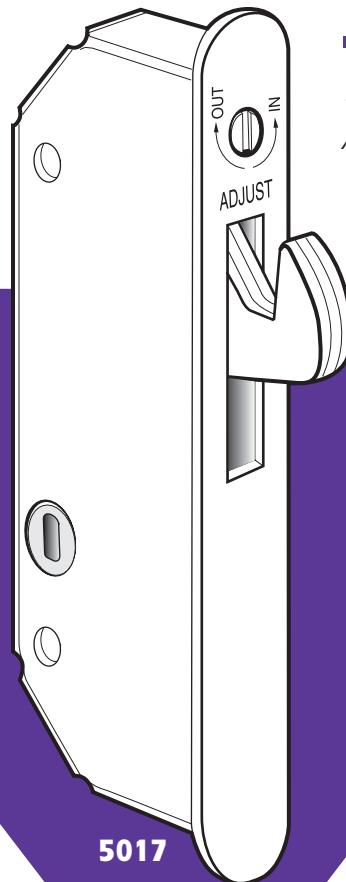

**4810
Box
Strike**

5017

▼ **Function**

For wood framed sliding doors the 5017 Deadbolt provides the same thousand pound strength that the MS1847 Deadbolt provides for metal stiles. A deeper backset clears the recessed jamb used with wood doors. Bolt throw is easily adjusted by means of a screw in the faceplate. Mounting is by through-bolts, which also secure the inside turn and outside cylinder when installed.

▼ **1015 Turn**

Available with 1016 blank plate shown for doors from .625 to 2.25 thickness. Without blank plate turn available (for use with cylinder pull) on doors from 1.42 to 2.00 thickness. Standard finish Ritecoat 130, Satin Aluminum enamel.

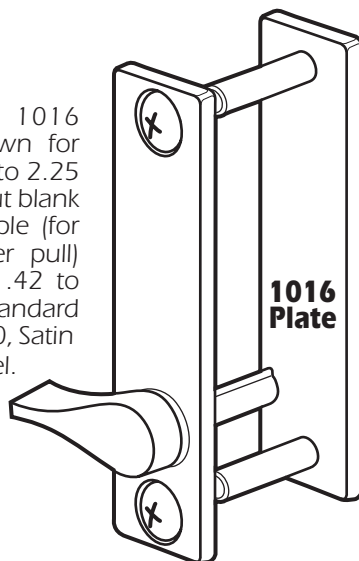

**1016
Plate**

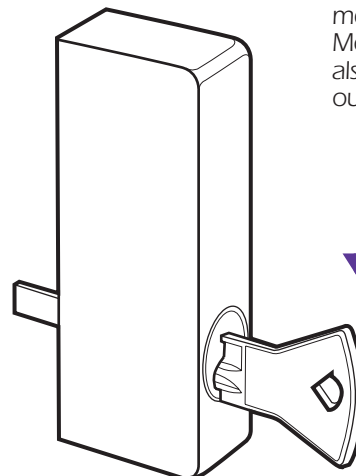

▼ **4026 Cylinder Pull**

Five pin-tumbler cylinder in zinc alloy housing. Standard finish Ritecoat 130 Satin Aluminum. 4026-01 dummy pull without cylinder also available.





5017 Wood Door Deadbolt

DIMENSIONS

INCHES
MILLIMETERS
Nominal, subject to tolerance extremes.

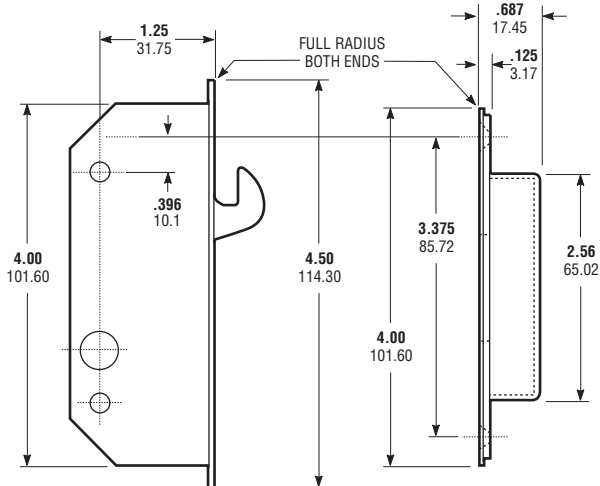
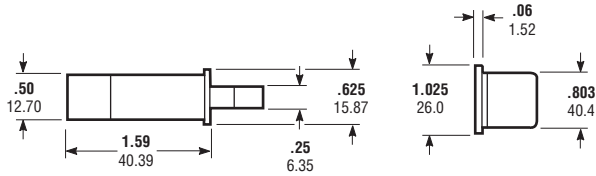

5017

4810

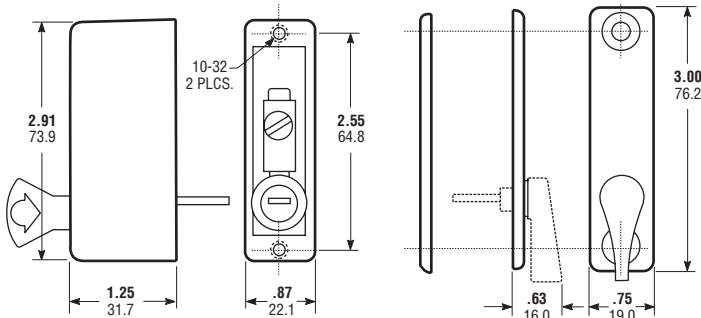

4026

1016 1015

MOUNTING SCREWS
AND POSTS FURNISHED.

INSTALLATION

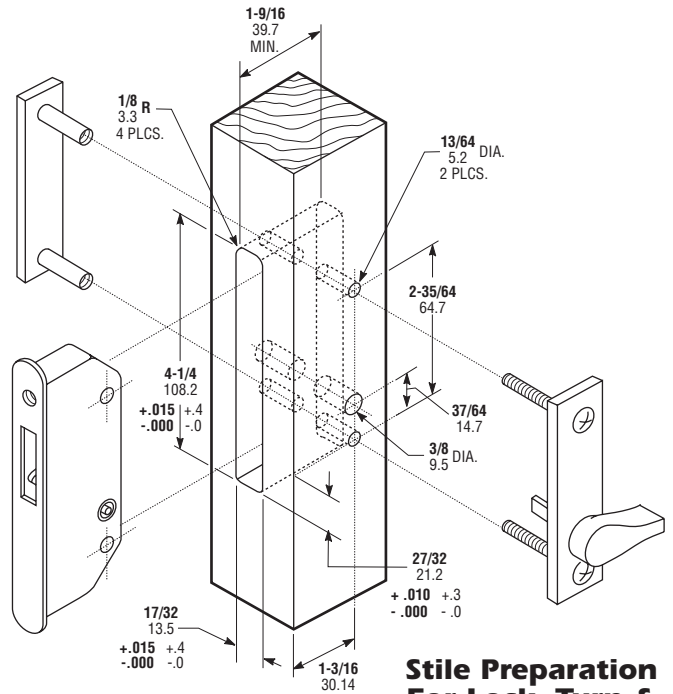

**Stile Preparation
For Lock, Turn &
Cylinder Pull**

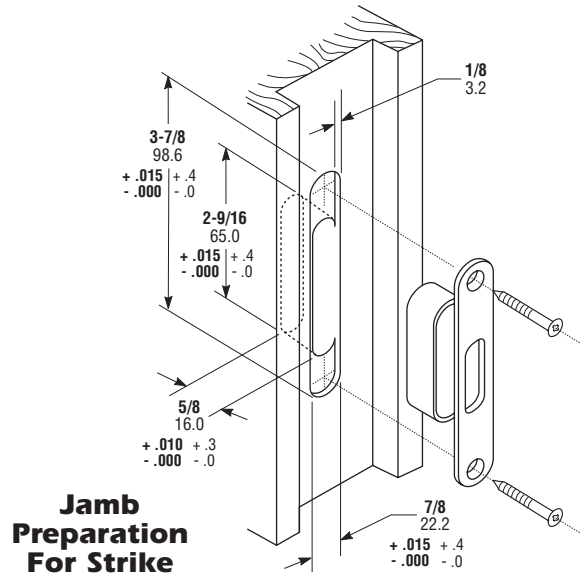

**Jamb
Preparation
For Strike**

HOW TO ORDER

*Specify quantity and Part Number.
Order related hardware separately.*

00 Standard
02 Self Latching

5017 - 00

*For installation with cylinder,
specify quantity of 4026 cylinder pulls and door thickness.*

OPTIONS

Order 5015 for Zinc plated Steel case and faceplate. 1015 Turn for inside operation is available alone (for use with 4026 cylinder pull on outside) or with a blank 1016 outside trimplate and binder posts (when cylinder is not required). 4810 Box Strike also available.