

## Deadlatch

### 4900 Series

ANSI/BHMA Type E8231 (Grade 1)

Both Flat and Radius Faceplates are supplied.

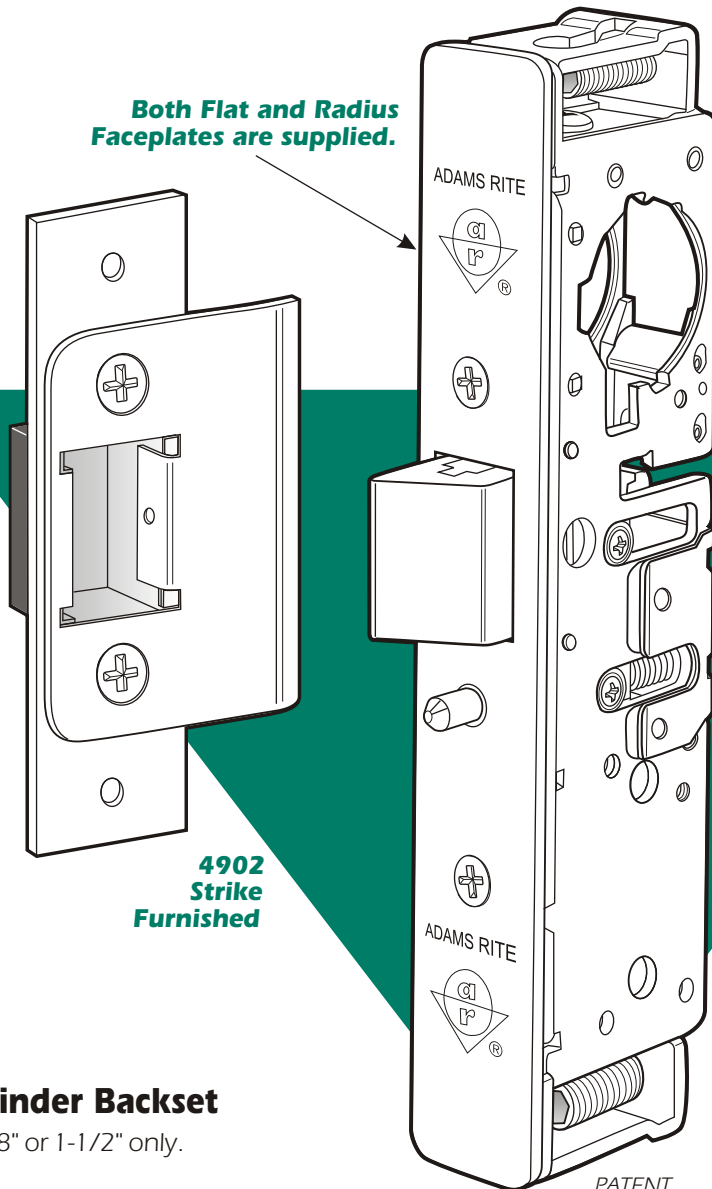

4902 Strike  
Furnished

PATENT  
PENDING

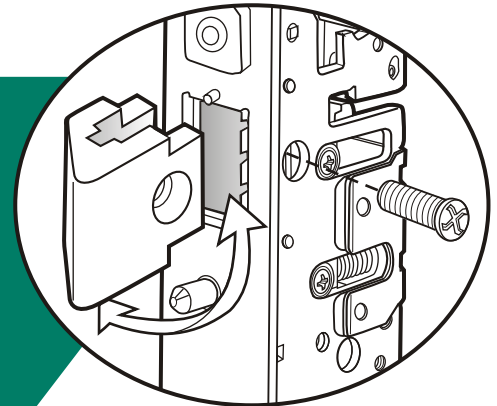

Field Reversible  
Latch Bolt

#### ▼ Cylinder Backset

1-1/8" or 1-1/2" only.

#### ▼ Case

Steel with corrosion-resistant plating. 7/8" x 5-13/16" x depth. (Depth varies by backset. See table on back page.) Screw-fastened tube spacer brackets allow for cleaner removal when tab mounting.

#### ▼ Function

Flexibility of traffic control and installation is offered by the 4900 Series Deadlatches. A reverse turn of the key while bolt is held retracted retains the bolt, to allow two-way traffic for applications which require free entrance at certain times and exit-only at other times. Interchangeable, without stile modification, with any MS1850A or MS1850S deadbolt of same backset and faceplate shape. Also retrofits to existing 4500/4700 Deadlatch preparations. 1-3/4" minimum door thickness required.

#### ▼ Latch Bolt

5/8" x 1" x 5/8" throw. Solid brass. Handing is easily reversible using only a screwdriver.

#### ▼ Auxiliary Latchpin

Stainless Steel. Deadlocks latch bolt to prevent "loiding" or case-knife entry.

#### ▼ Faceplates

1" x 6-7/8". Both flat and radius faceplates are supplied. Flat faceplates can also be adjusted in the field for right or left beveled edge doors.

#### ▼ Strikes

Standard strike furnished is 4902 for flat jamb where door closes flush or nearly flush. Specify 4901 for retrofit installations. Also available: radius strike for opposite stile in paired doors and long lip strikes for centerhinge doors. (See page SW-24 and Electric Strike section.)

#### ▼ Operation

Turn key or operate handle or paddle to retract spring-loaded latch bolt. To hold bolt retracted, push it in and secure by reverse turn of key (see back page). Uses any standard mortise cylinder with MS® cam (see page SW-28).



**ADAMS RITE**  
MANUFACTURING CO.

260 Santa Fe Street  
Pomona, California 91767  
(800) 872-3267 Fax: (909) 232-7329  
www.adamsrite.com



# 4900 Series Deadlatch

## DIMENSIONS

**INCHES**  
**MILLIMETERS**

Nominal, subject to tolerance extremes.

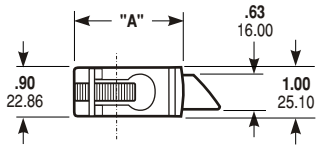

BACKSET	"A"
<b>1-1/8"</b> 28.6	<b>1.76</b> 44.7
<b>1-1/2"</b> 38.1	<b>2.14</b> 54.3

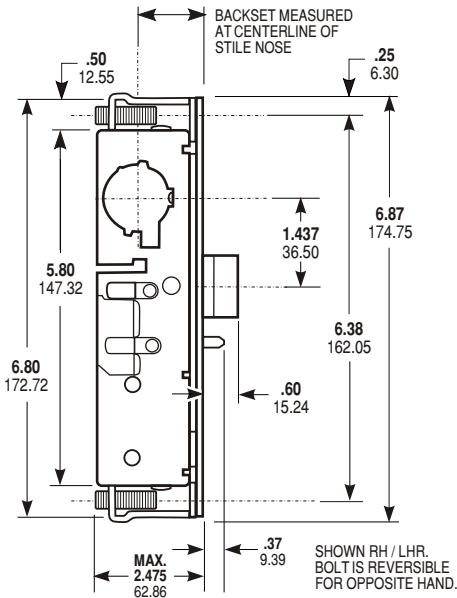

**ARMORED FACEPLATE**  
1" x 6-7/8"

FLAT

RADIUS

RADIUS w/WEATHERSTRIP  
ORDER SEPARATELY  
P/N 24-0137-03-XXX

FLAT FACEPLATE CAN BE ADJUSTED FOR RIGHT OR LEFT BEVELED EDGE DOORS

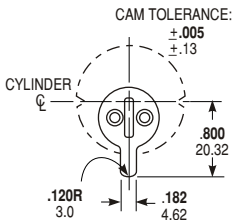

### Cylinder Cam

4900 Series Deadlatches are operable by any standard 1-5/32" diameter mortise cylinder with special MS® cam dimensioned as shown. Cylinders with MS® cams can be readily obtained from most cylinder manufacturers. See page SW-28 for cylinder make and trim ring information.

## HOW TO ORDER

Specify quantity and the following information.  
Order related hardware separately.

<b>Backset</b>	<b>Handing*</b>
<b>3</b> 1-1/8"	<b>5</b> LH or RHR
<b>4</b> 1-1/2"	<b>6</b> RH or LHR

\*Handing can be reversed in field.

# 4900-35-201-628

<b>Strike Size**</b>	<b>Strike Shape/Lip Length**</b>	<b>Faceplate Finish</b>
<b>1</b> 4.63" (4901)	<b>01</b> Flat/Standard Jamb	<b>628</b> Clear Anodized
<b>2</b> 2.63" (4902)	<b>02</b> Radius/Standard Stile	<b>313</b> Dark Bronze Anod.
	<b>17</b> Flat/Centerhung 4.0" Jamb	<b>335</b> Black Anodized
	<b>21</b> Flat/Centerhung 4.5" Jamb	
	<b>XX</b> Other Lip lengths	

For other available finishes, contact factory.

\*\*See page SW-24 4901/4902 for available strike options.

## INSTALLATION

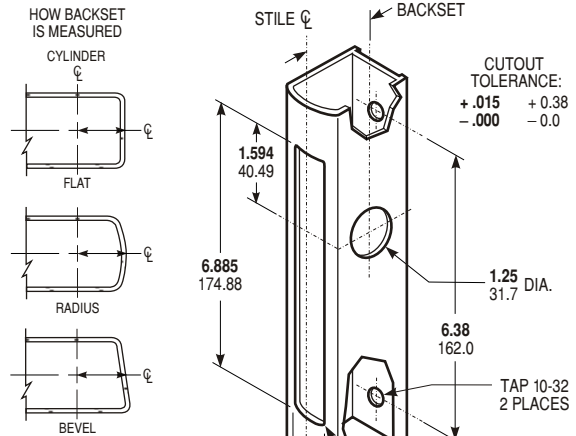

### Stile Preparation

Identical to MS1850A or MS1850S Series  
(See prep for 4591 Paddle)

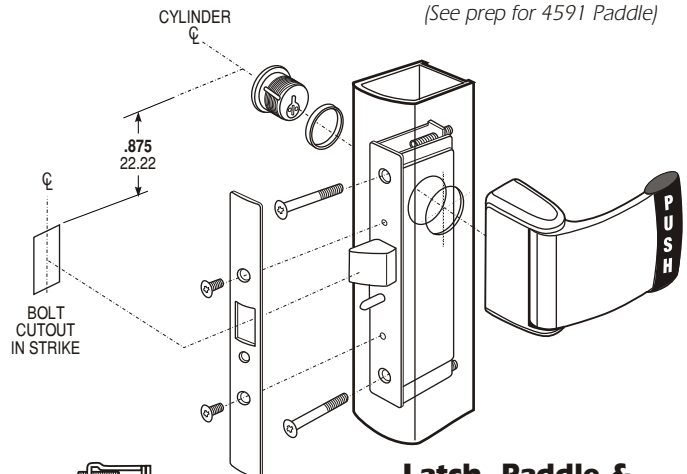

### Latch, Paddle & Cylinder Installation

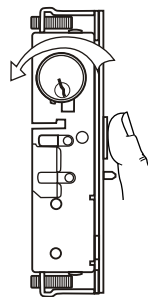

### Bolt Holdback

A reverse turn of the key (while bolt is held fully retracted) retains the bolt, allowing the door to be free swinging.

## OPTIONS

Backset, Strike and Finish must be specified when ordering. For handles, see page SW-25 & 26. For Paddles, see page SW-27 and SW-27a. For outside entry Latch Pull, see page SW-27b. Order Radius Faceplate with Weatherseal separately, P/N 24-0137-03-XXX (specify finish). See electric strike section for compatible access control products. See 4920AN Series for wood and steel door applications.

## STANDARD PACKAGE

Individually boxed with Flat and Radius Faceplates, Strike and machine screws for mounting. Order cylinders, paddle, handle or latch pull separately. Shipping weight: 1-1/4 lbs.