

Deadlatch For Metal Stile Glass Doors

4710 Series

ANSI/BHMA Type E8231 (Grade 1)

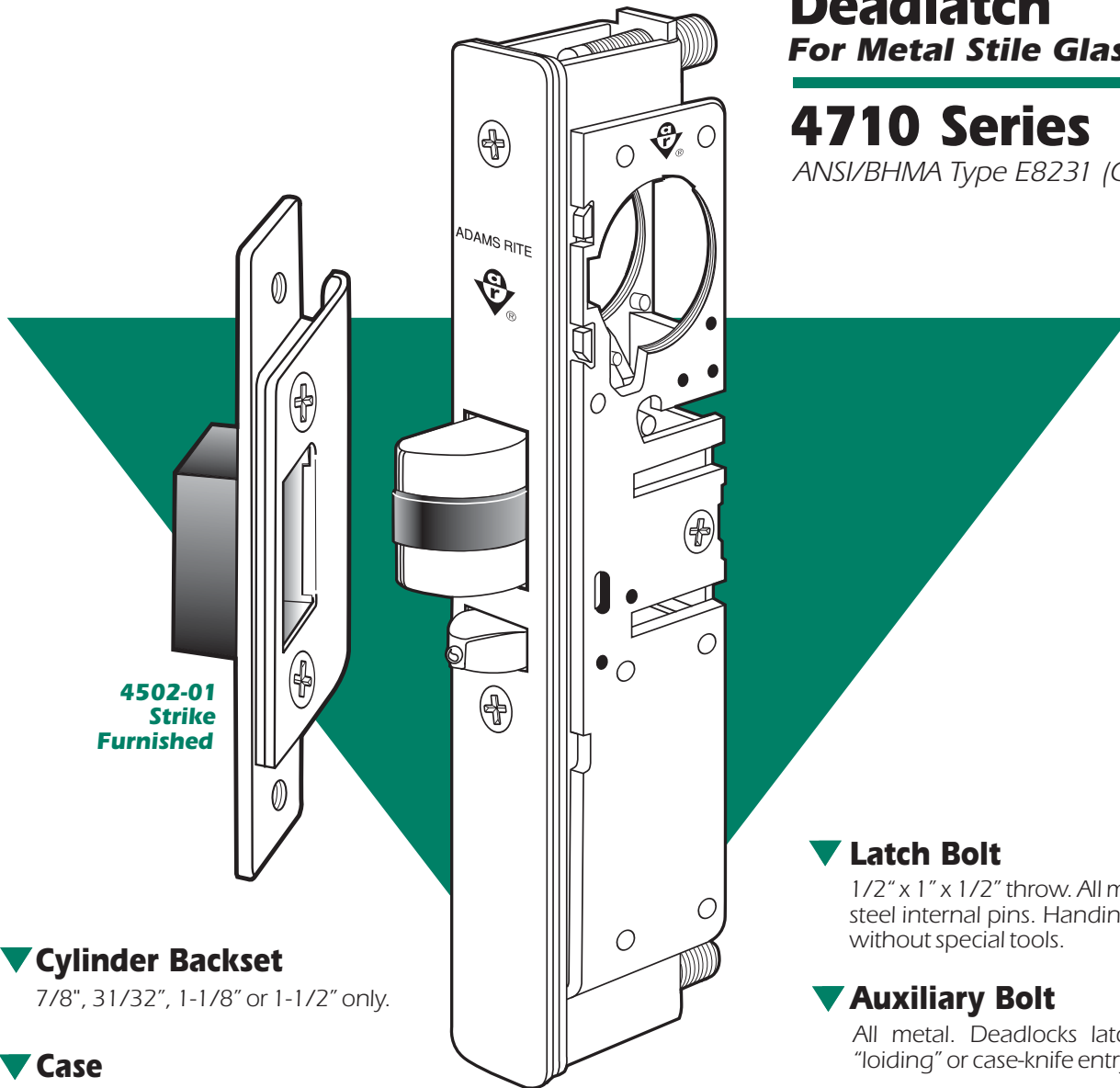

**4502-01
Strike
Furnished**

▼ Cylinder Backset

7/8", 31/32", 1-1/8" or 1-1/2" only.

▼ Case

Steel with corrosion-resistant plating. 1" x 5-13/16" x depth. (Depth varies by backset. See table on back page.)

▼ Function

Flexibility of traffic control during and after business hours is offered by 4710 Series Deadlatches. A reverse turn of the key while bolt is held retracted retains the bolt, to allow two-way traffic for hospitals, banks, stores and other buildings which require free entrance at certain times and exit-only at other times. Interchangeable, without stile modification, with any MS1850A or MS1850S deadbolt of same backset and faceplate shape. (They do not, however, provide the same maximum security level as the MS® Deadbolt.)

PATENTED

▼ Latch Bolt

1/2" x 1" x 1/2" throw. All metal with hardened steel internal pins. Handing is easily reversible without special tools.

▼ Auxiliary Bolt

All metal. Deadlocks latch bolt to prevent "loiding" or case-knife entry.

▼ Strikes

Standard strike furnished is 4502-01 for flat jamb where door closes flush or nearly flush. Also available: radius strike for opposite stile in paired doors; longer strike (4501) to cover slot strike of MS® lock; long lip strikes for centerhung doors. (See page SW-24 and Electric Strike section.)

▼ Operation

Turn key or operate handle to retract spring-loaded latch bolt. To hold bolt retracted, push it in and secure by reverse turn of key (see back page). Uses any standard mortise cylinder with MS® cam (see page SW-28).



ADAMS RITE
MANUFACTURING CO.

260 Santa Fe Street
Pomona, California 91767
(800) 872-3267 Fax: (800) 232-7329
www.adamsrite.com



4710 Series Deadlatch

DIMENSIONS

INCHES
MILLIMETERS

Nominal, subject to tolerance extremes.

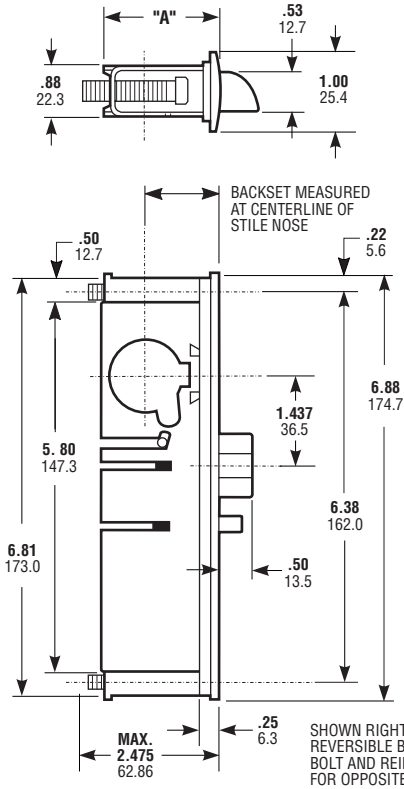

BACKSET	"A"
7/8"	1.51
22.2	38.3
31/32"	1.60
24.6	40.6
1-1/8"	1.76
28.6	44.7
1-1/2"	2.14
38.1	54.3

ARMORED FACEPLATE 1" x 6-7/8"	
FLAT	4710
RADIUS	4711
RADIUS w/WEATHERSTRIP	4711W
LH BEVEL	4712(LH)
RH BEVEL	4712(RH)

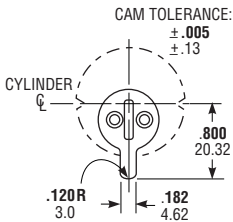

Cylinder Cam

4710 Series Deadlatches are operable by any standard 1-5/32" diameter mortise cylinder with special MS® cam dimensioned as shown. Cylinders with MS® cams can be readily obtained from most cylinder manufacturers. See page SW-28 for cylinder make and trim ring information.

INSTALLATION

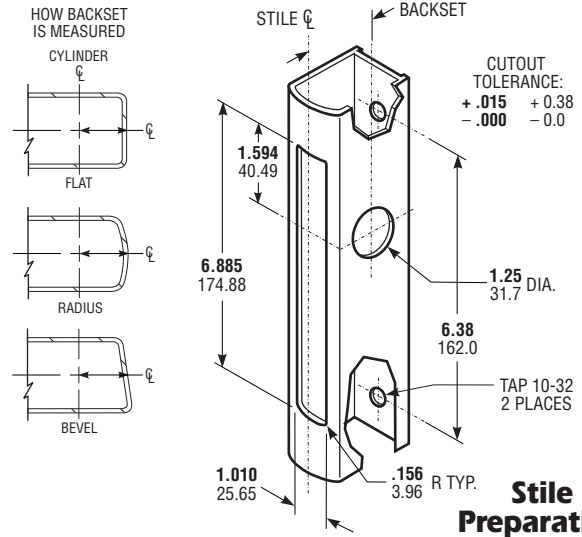

Stile Preparation

Identical to MS1850A Series
(See also prep for 4590 Paddle)

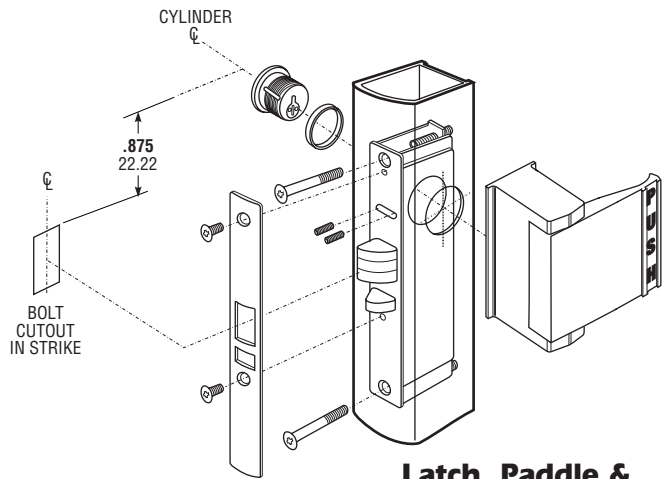

Latch, Paddle & Cylinder Installation

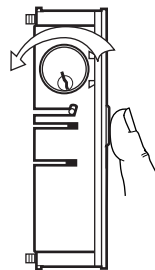

Bolt Holdback

A reverse turn of the key (while bolt is held fully retracted) retains the bolt, allowing the door to be free swinging.

HOW TO ORDER

Specify quantity and the following information.
Order related hardware separately.

Faceplate Shape	Backset	Handing
0 Flat	1 7/8"	5 LH or RHR
1 Radius	2 31/32"	6 RH or LHR
1W Radius w/Wstrip	3 1-1/8"	
2 Bevel	4 1-1/2"	

4711-36-201-628

Strike Size	Strike Shape/Lip Length	Faceplate Finish
1 4.63" (4501)*	01 Flat/Standard Jamb	628 Clear Anodized
2 2.63" (4502)*	02 Radius/Standard Stile	313 Dark Bronze Anod.
	17 Flat/Centerhung 4.0" Jamb	335 Black Anodized
	21 Flat/Centerhung 4.5" Jamb	
	XX Other Lip lengths	

*See pg SW-26

See 4501/4502 strikes for options.

For other available finishes, contact factory.

OPTIONS

Backset, Faceplate Shape, Finish, Strike and Handing must be specified when ordering. For Handles, see page SW-25 & 26. For Paddles, see page SW-27.

STANDARD PACKAGE

Individually boxed with strike and machine screws for mounting. Cylinders, paddle or handle available at extra cost. Shipping weight: 1-1/4 lbs. Also available in a 25 unit pack for volume users.