



Features & Dimensions

Narrow Stile Mortise Exit Device

ANSI/BHMA
Grade 1

Handing
Specify handing and bevel if applicable.
Lever Entry Trim is field reversible.

Pushbar Length
Standard Sizes: Dimensioned for 30", 36", 42" & 48" openings. Standard width bars can be field cut to the next smallest opening width. Backsets available in 31/32", 1-1/8", 1-1/2".

Door Thickness
Suits 1-3/4" standard. Can be modified for thicker doors.

Stile Width
Minimum 2" Stile. Fits Narrow, Medium and Wide Stile aluminum doors.

Projection
2-5/8" when fully projected,
1-5/8" when dogged.

Materials
Pushbar made of extruded aluminum, clad or anodized in a variety of finishes.

Dogging
Standard dogging with hex key or cylinder dogging option. Electric dogging also available.

Fasteners
Standard self-tapping screws.

Strike
Made of stainless steel. Supplied with exit device. See Strike options below.

Cylinders (order separately)
Cylinder x Fixed Pull:
(Function 03)
Accepts any standard Mortise cylinder. Entry Lever or Thumbturn:
(Functions 08, 09, 11, 12)
Accepts any standard diameter Mortise cylinder with MS® cam. Accommodates cylinder lengths from 1" to 1-1/4".

Warranty
Two year limited.

AVAILABLE FINISHES	
313	Dark Bronze Anodized
335	Black Anodized
628	Clear Anodized
US3	Bright Brass
US4	Satin Brass
US9	Bright Bronze
US10	Satin Bronze
10B	Dark Bronze (Trim only)
US32	Bright Stainless
US32D	Satin Stainless

Consult factory for special finishes.

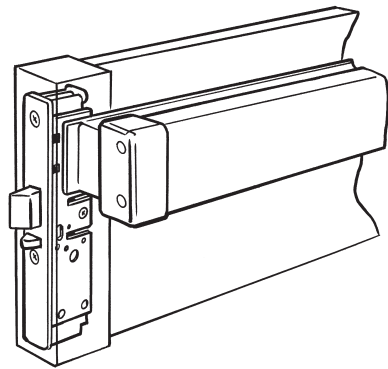

8400
The 8400 was designed to fit standard cutout used for the Adams Rite MS® Deadbolt on aluminum stile glass doors. Backsets available: 31/32", 1-1/8" & 1-1/2".

Pushbar Dimensions

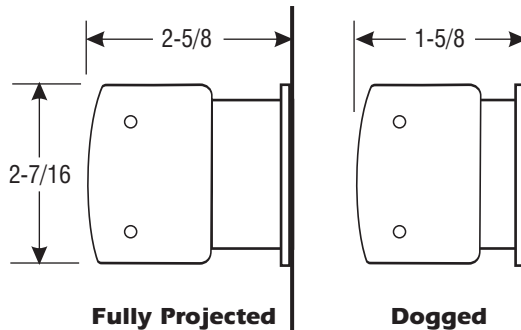

Strikes

A variety of strikes are available for different applications and conditions.

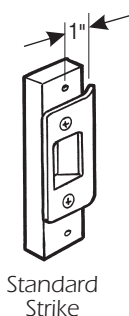

Standard Strike

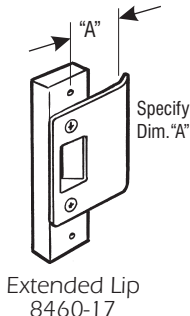

Extended Lip 8460-17

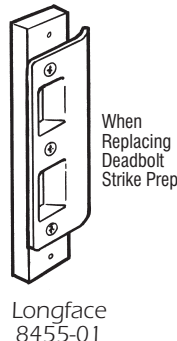

Longface 8455-01

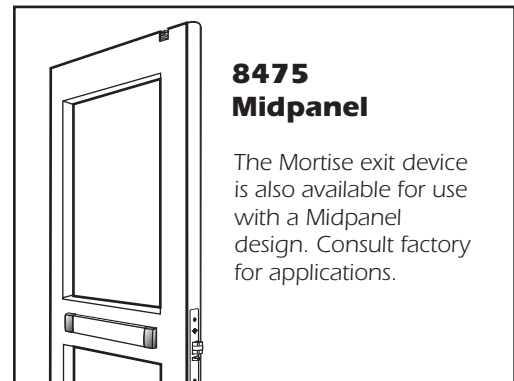

8475 Midpanel

The Mortise exit device is also available for use with a Midpanel design. Consult factory for applications.