

Heavy-Duty Deadbolt

2331

ANSI/BHMA Type E16121 (Grade 1)

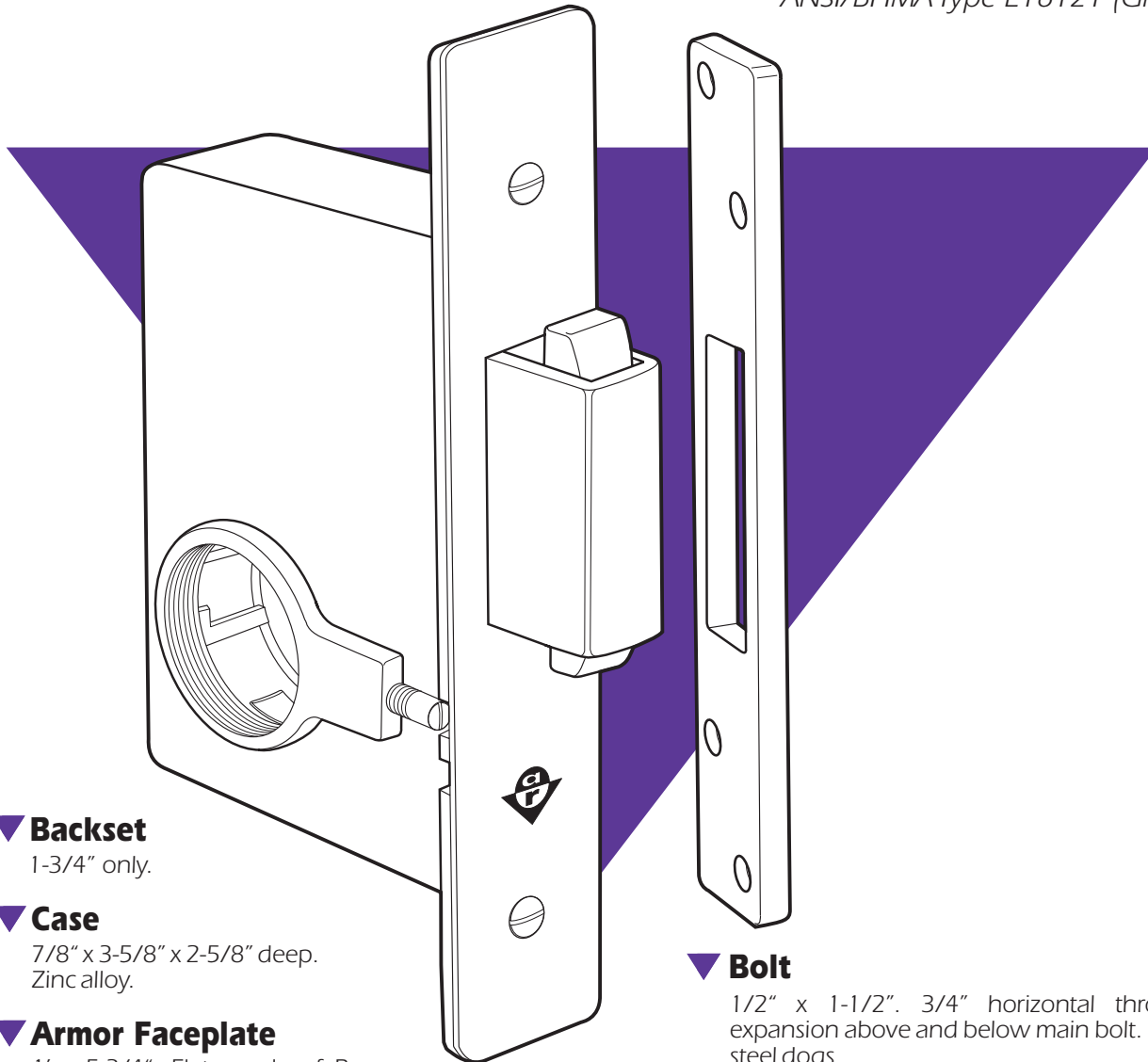

▼ Backset

1-3/4" only.

▼ Case

7/8" x 3-5/8" x 2-5/8" deep.
Zinc alloy.

▼ Armor Faceplate

1" x 5-3/4". Flat, made of Brass.
Available in different trim finishes.

▼ Function

A heavy-duty deadbolt for heavy-duty metal or wood sliding doors, the 2331 throws a massive brass bolt into its strike, then expands two stainless steel dogs to secure the door. A single turn of key expands or retracts the bolt. Operates with standard mortise cylinder (standard cam) or with standard mortise cylinder thumbturn. There is no latch action.

▼ Bolt

1/2" x 1-1/2". 3/4" horizontal throw, with 11/32" expansion above and below main bolt. Brass with stainless steel dogs.

▼ Strike

1/8" x 1" x 4-11/16" with 5/8" x 1-5/8" opening. Brass, with four-screw mounting. Trim finish same as faceplate.

▼ Operation

360° turn of key or thumbturn extends and expands or retracts and withdraws the bolt. Key cannot be removed unless bolt is positively locked or totally retracted.



ADAMS RITE
MANUFACTURING CO.

260 Santa Fe Street
Pomona, California 91767
(800) 872-3267 Fax:(800) 232-7329
www.adamsrite.com



2331 Heavy-Duty Deadbolt

DIMENSIONS

INCHES
MILLIMETERS

Nominal, subject to tolerance extremes.

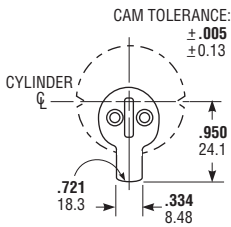
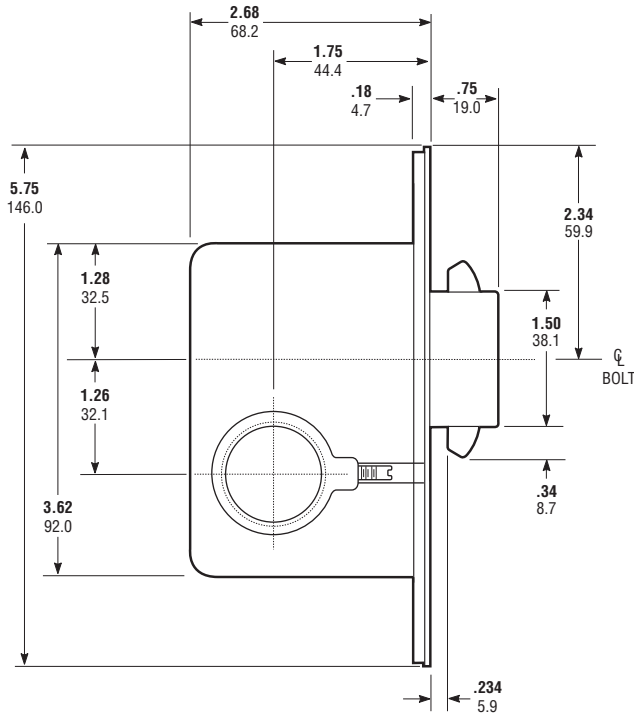
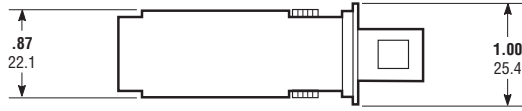

Cylinder Cam

2331 Deadbolts are operable by any standard 1-5/32" diameter mortise cylinder with standard cam dimensions as shown. Cylinders with such cams can be readily obtained from most cylinder manufacturers.

INSTALLATION

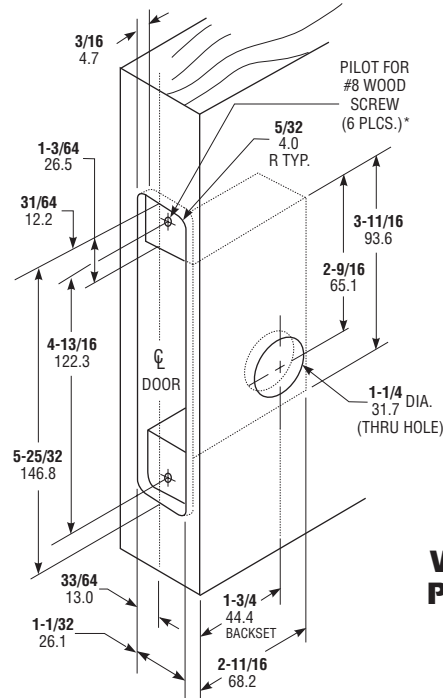

NOTE: DIM'S SHOWN ARE RECOMMENDED MINIMUM.

*TAP FOR 8-32 MACHINE SCREWS FOR METAL

Wood Door Preparation

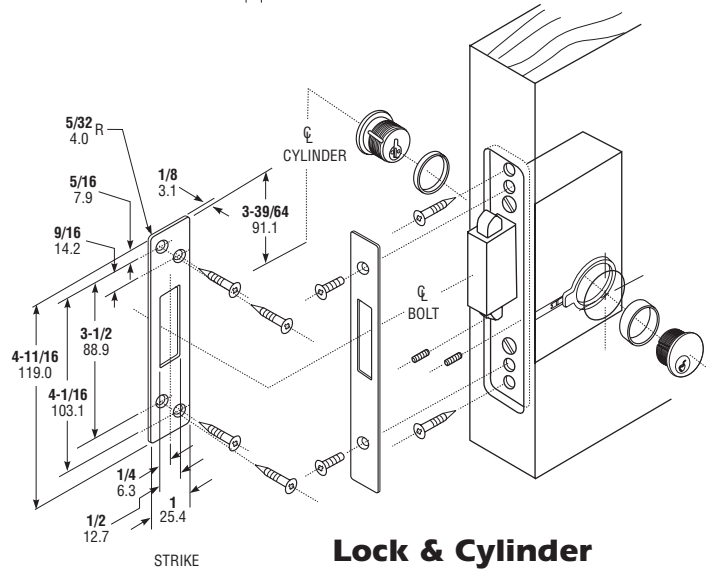

Lock & Cylinder Installation

HOW TO ORDER

Specify quantity and the following information. Order related hardware separately.

Finish

- 605** Bright Brass
- 612** Satin Bronze
- 625** Bright Chrome
- 626** Satin Chrome

2331 - 625

OPTIONS

Specify trim finish: US3 Polished Brass (605), US10 Satin Bronze (612), US26 Bright Chrome (625) or US26D Satin Chrome (626).

STANDARD PACKAGE

Individually boxed with strike and wood screws for mounting lock and strike. Shipping weight: 2 lbs.